



VISHWANIKETAN

Reg. No. F9819 - Raigad Society Reg. No. MAH/207/2012/Raigad

Corporate Office : B - 52, Sector - 12, Kharghar, Navi-Mumbai - 410210

Campus : Survey No. 52, Kumbhivali, Near Khalapur Toll Naka, off. Mumbai-Pune Expressway, Tal - Khalapur
Dist. - Raigad - Pin- 410 202 • Telephone - 02192 - 274 206/07/08/10

Dr. Ramjee Prasad
President

Dr. S. S. Inamdar
Vice - President

Mr. Sunil Bangar
Secretary

Reply to Query on Metric Id 3.4.1:

List of collaboration/linkages for faculty exchange, student exchange, internship, field trip, on-the-job training, research, etc.

S.N.	Title of the collaborative activity	Name of the collaborating / linking agency	Year of collaboration	Duration
1	On-the-job Training (Design of Mechanical Systems)	Mechatol Engineering Solutions	2020	1 Year
2	On-the-job Training (Drone)	India First Robotics	2020	6 Months
3	On-the-job Training (Cyber Security)	MOSCOS Online Services LLP	2020	6 Months
4	On-the-job Training (PLC SCADA)	BITC 2104 & LD-Engineering	2020	6 Months
5	On-the-job Training (ARDUINO)	Dnyananda Sustainables Engineering Solution	2020	6 Months
6	On-the-job Training (Robotics)	India First Robotics	2020	6 Months
7	Research (International Ph.D. Program)	National Technical University Ukraine Igorskirosky KPI	2020	3 Years
8	Research (CENTRAL)	European Commission	2020	3 Years
9	UG Fellowship (Project Based Summer Internship Program at Abroad Universities)	Mae Fah Luang University	2019	6 Weeks
10	UG Fellowship (Project Based Summer Internship Program at Abroad Universities)	Ural Fedral University, Russia	2019	6 Weeks
11	UG Fellowship (Project Based Summer Internship Program at Abroad Universities)	University of Rome Tor Vegata, Italy	2019	6 Weeks
12	UG Fellowship (Project Based Summer Internship Program at Abroad Universities)	Poznan University of Technology, Poland	2019	6 Weeks
13	UG Fellowship (Project Based Summer Internship Program at Abroad Universities)	Athens Information Technology, Greece	2019	6 Weeks
14	UG Fellowship (Project Based Summer Internship Program at Abroad Universities)	Tesside University, Middlesbrough	2019	6 Weeks
15	UG Fellowship (Project Based Summer Internship Program at Abroad Universities)	University of Arkansas, Little Rock	2019	6 Weeks



VISHWANIKETAN

Reg. No. F9819 - Raigad Society Reg. No. MAH/207/2012/Raigad

Corporate Office : B - 52, Sector - 12, Kharghar, Navi-Mumbai - 410210
Campus : Survey No. 52, Kumbhivali, Near Khalapur Toll Naka, off. Mumbai-Pune Expressway, Tal - Khalapur
Dist. - Raigad - Pin- 410 202 • Telephone - 02192 - 274 206/07/08/10

Dr. Ramjee Prasad
President

Dr. S. S. Inamdar
Vice - President

Mr. Sunil Bangar
Secretary

16	UG Fellowship (Project Based Summer Internship Program at Abroad Universities)	University of Nevada Las Vegas USA	2019	6 Weeks
17	On-the-job Training (Design of Mechanical Systems)	Mechatol Engineering Solutions	2019	1 Year
18	Research (International Ph.D. Program)	National Technical University Ukraine Igerskirosky KPI	2019	3 Years
19	Research (CENTRAL)	European Commission	2019	3 Years
20	On-the-job Training (Kalekar Constructions)	Kalekar Constructions, Neral	2019	6 Months
21	On-the-job Training (Zara P Care)	Zara P Care	2019	6 Months
22	On-the-job Training (Electric Vehicle Design)	BABA Automobiles, Jaipur	2019	1 Year
23	UG Fellowship (Project Based Summer Internship Program at Abroad Universities)	Technical University of Sofia, Bulgaria	2018	6 Weeks
24	UG Fellowship (Project Based Summer Internship Program at Abroad Universities)	University of Rome Tor Vegata, Italy	2018	6 Weeks
25	UG Fellowship (Project Based Summer Internship Program at Abroad Universities)	Ural Fedral University, Russia	2018	6 Weeks
26	UG Fellowship (Project Based Summer Internship Program at Abroad Universities)	National Technological University Ukraine Kyiv Poletechnic	2018	6 Weeks
27	UG Fellowship (Project Based Summer Internship Program at Abroad Universities)	Stevens Institute of Technology New Jersey USA	2018	6 Weeks
28	UG Fellowship (Project Based Summer Internship Program at Abroad Universities)	University of Arkansas, Little Rock	2018	6 Weeks
29	UG Fellowship (Project Based Summer Internship Program at Abroad Universities)	International Technological University, San Jose	2018	6 Weeks
30	UG Fellowship (Project Based Summer Internship Program at Abroad Universities)	Tesside University, Middlesbrough	2018	6 Weeks
31	On-the-job Training (BITC)	BITC, Pune	2018	6 Months
32	UG Fellowship (Project Based Summer Internship Program at Abroad Universities)	Technical University of Sofia, Bulgaria	2017	6 Weeks
33	UG Fellowship (Project Based Summer Internship Program at Abroad Universities)	Athens Information Technology, Greece	2017	6 Weeks

TRUE COPY



VISHWANIKETAN

Reg. No. F9819 - Raigad Society Reg. No. MAH/207/2012/Raigad

Corporate Office : B - 52, Sector - 12, Kharghar, Navi-Mumbai - 410210

Campus : Survey No. 52, Kumbhivali, Near Khalapur Toll Naka, off. Mumbai-Pune Expressway, Tal - Khalapur

Dist. - Raigad - Pin- 410 202 • Telephone - 02192 - 274 206/07/08/10

Dr. Ramjee Prasad
President

Dr. S. S. Inamdar
Vice - President

Mr. Sunil Bangar
Secretary

34	UG Fellowship (Project Based Summer Internship Program at Abroad Universities)	University of Rome Tor Vegata, Italy	2017	6 Weeks
35	UG Fellowship (Project Based Summer Internship Program at Abroad Universities)	Ural Fedral University, Russia	2017	6 Weeks
36	UG Fellowship (Project Based Summer Internship Program at Abroad Universities)	Stevens Institute of Technology New Jersey USA	2017	6 Weeks
37	UG Fellowship (Project Based Summer Internship Program at Abroad Universities)	University of Arkansas, Little Rock	2017	6 Weeks
38	UG Fellowship (Project Based Summer Internship Program at Abroad Universities)	National Technological University Ukraine Kyiv Poletchnic	2017	6 Weeks
39	On-the-job Training (Design of Mechanical Systems)	Mechatol Engineering Solutions	2017	1 Year

TRUE COPY

Principal
Vishwaniketan's (IMEET)

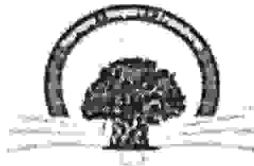

VISHWANIKETAN

Reg. No. F9819 - Raigad Society Reg. No. MAH/207/2012/Raigad

Corporate Office : B - 52, Sector - 12, Kharghar, Navi-Mumbai - 410210

Campus : Survey No. 52, Kumbhivali, Near Khalapur Toll Naka, off. Mumbai-Pune Expressway
Dist. - Raigad - Pin- 410 202 • Telephone - 02192 - 274 206/07/08/10

Dr. Ramjee Prasad
President

Dr. S. S. Inamdar
Vice - President

Mr. S

Reply to Query on Metric Id 3.4.1: Photographs of activities with caption



Team
MFL, Thailand 2019



Team
URFU, Russia 2019

TRUE COPY

Principal
Vishwaniketan's (IMEET)



VISHWANIKETAN

Reg. No. F9819 - Raigad Society Reg. No. MAH/207/2012/Raigad

Corporate Office : B - 52, Sector - 12, Kharghar, Navi-Mumbai - 410210

Campus : Survey No. 52, Kumbhivali, Near Khalapur Toll Naka, off. Mumbai-Pune Expressway, Tal - Khalapur
Dist. - Raigad - Pin- 410 202 • Telephone - 02192 - 274 206/07/08/10

Dr. Ramjee Prasad
President

Dr. S. S. Inamdar
Vice - President

Mr. Sunil Bangar
Secretary



Team
TVUS, Italy 2019

CLOSING CEREMONY AT AIT GREECE



Team
AIT, Greece 2019

TRUE
LET'S MEET



VISHWANIKETAN

Reg. No. F9819 - Raigad Society Reg. No. MAH/207/2012/Raigad

Corporate Office : B - 52, Sector - 12, Kharghar, Navi-Mumbai - 410210

Campus : Survey No. 52, Kumbhivali, Near Khalapur Toll Naka, off. Mumbai-Pune Expressway, Tal - Khalapur

Dist. - Raigad - Pin- 410 202 • Telephone - 02192 - 274 206/07/08/10

Dr. Ramjee Prasad
President

Dr. S. S. Inamdar
Vice - President

Mr. Sunil Bangar
Secretary



Team
Teesside, UK 2019



Team
Arkansas, USA 2019

TRUE COPY

Principal
Vishwaniketan's (iMEET)



VISHWANIKETAN

Reg. No. F9819 - Raigad Society Reg. No. MAH/207/2012/Raigad

Corporate Office : B - 52, Sector - 12, Kharghar, Navi-Mumbai - 410210

Campus : Survey No. 52, Kumbhivali, Near Khalapur Toll Naka, off. Mumbai-Pune Expressway, Tal - Khalapur
Dist. - Raigad - Pin- 410 202 • Telephone - 02192 - 274 206/07/08/10

Dr. Ramjee Prasad
President

Dr. S. S. Inamdar
Vice - President

Mr. Sunil Bangar
Secretary



Team
Nevada, USA 2019

CLOSING CEREMONY AT URAL FEDERAL UNIVERSITY, RUSSIA



Team URFU,
Russia, 2017

TRUE COPY

[Signature]
Vishwaniketan's (Official)



VISHWANIKETAN

Reg. No. F9819 - Raigad Society Reg. No. MAH/207/2012/Raigad

Corporate Office : B - 52, Sector - 12, Kharghar, Navi-Mumbai - 410210

Campus : Survey No. 52, Kumbhivali, Near Khalapur Toll Naka, off. Mumbai-Pune Expressway, Tal - Khalapur
Dist. - Raigad - Pin- 410 202 • Telephone - 02192 - 274 206/07/08/10

Dr. Ramjee Prasad
President

Dr. S. S. Inamdar
Vice - President

Mr. Sunil Bangar
Secretary

Stevens Institute of Technology, USA



Team
Stevens, USA, 2017



Team
TUS, Bulgaria 2017

TRUE COPY

Principal

Vishwaniketan's (TIMEET)



VISHWANIKETAN

Reg. No. F9819 - Raigad Society Reg. No. MAH/207/2012/Raigad

Corporate Office : B - 52, Sector - 12, Kharghar, Navi-Mumbai - 410210

Campus : Survey No. 52, Kumbhivali, Near Khalapur Toll Naka, off. Mumbai-Pune Expressway, Tal - Khalapur

Dist. - Raigad - Pin- 410 202 • Telephone - 02192 - 274 206/07/08/10

Dr. Ramjee Prasad
President

Dr. S. S. Inamdar
Vice - President

Mr. Sunil Bangar
Secretary



Team
TVUR, 2017

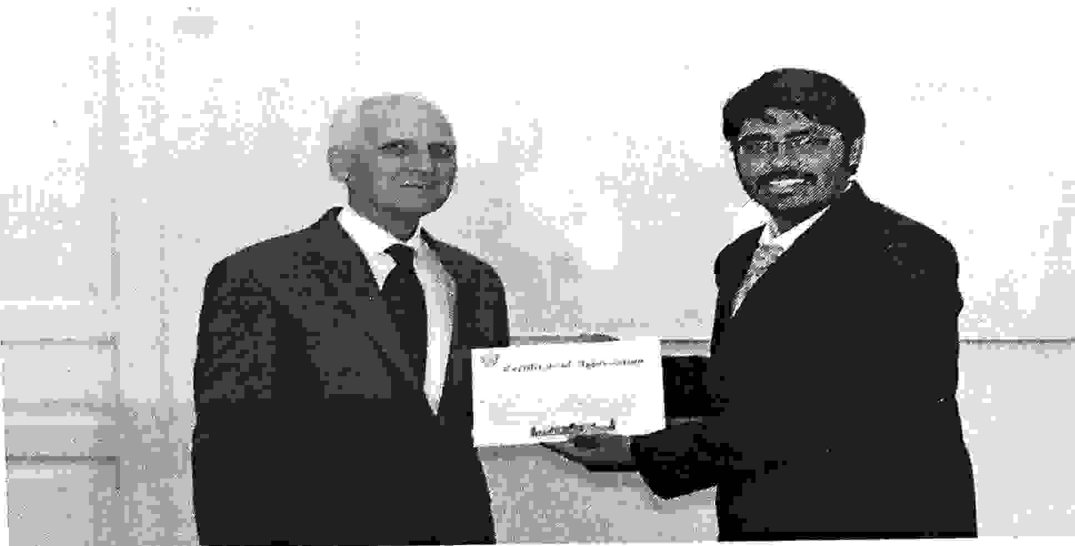

Team
NTUU, Ukraine 2018

TRUE COPY

Pradeep
Vishwaniketan's (INDIET)



VISHWANIKETAN

Reg. No. F9819 - Raigad Society Reg. No. MAH/207/2012/Raigad

Corporate Office : B - 52, Sector - 12, Kharghar, Navi-Mumbai - 410210

Campus : Survey No. 52, Kumbhivali, Near Khalapur Toll Naka, off. Mumbai-Pune Expressway, Tal - Khalapur

Dist. - Raigad - Pin- 410 202 • Telephone - 02192 - 274 206/07/08/10

Dr. Ramjee Prasad
President

Dr. S. S. Inamdar
Vice - President

Mr. Sunil Bangar
Secretary

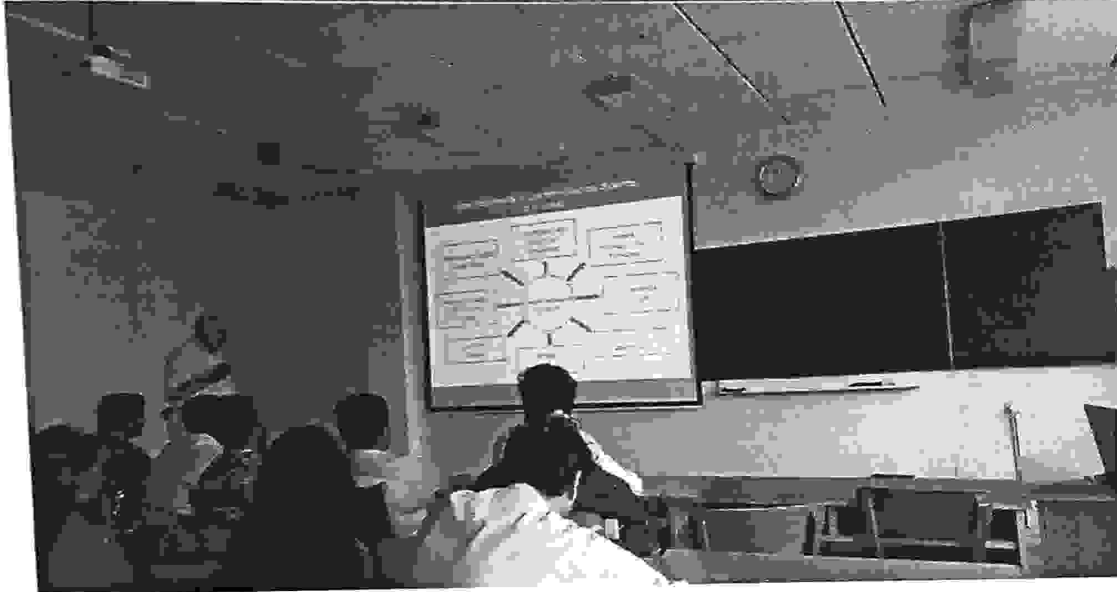

Team
Stevens, USA 2018



Team
UALR, 2018

Vishwaniketan

Vishwaniketan's (IMEET)



VISHWANIKETAN

Reg. No. F9819 - Raigad Society Reg. No. MAH/207/2012/Raigad

Corporate Office : B - 52, Sector - 12, Kharghar, Navi-Mumbai - 410210

Campus : Survey No. 52, Kumbhivali, Near Khalapur Toll Naka, off. Mumbai-Pune Expressway, Tal - Khalapur

Dist. - Raigad - Pin- 410 202 • Telephone - 02192 - 274 206/07/08/10

Dr. Ramjee Prasad
President

Dr. S. S. Inamdar
Vice - President

Mr. Sunil Bangar
Secretary

NTUU, Ukraine



Team
NTUU, Ukraine, 2017



Team
ITU, USA, 2018

TRUE COPY

Principal
Vishwaniketan's (iMEET)



VISHWANIKETAN

Reg. No. F9819 - Raigad Society Reg. No. MAH/207/2012/Raigad

Corporate Office : B - 52, Sector - 12, Kharghar, Navi-Mumbai - 410210

Campus : Survey No. 52, Kumbhivalli, Near Khalapur Toll Naka, off. Mumbai-Pune Expressway, Tal - Khalapur
Dist. - Raigad - Pin- 410 202 • Telephone - 02192 - 274 206/07/08/10

Dr. Ramjee Prasad
President

Dr. S. S. Inamdar
Vice - President

Mr. Sunil Bangar
Secretary



Team
UALR, 2017



Team
AIT, 2017

TRUE COPY

[Signature]
Vishwaniketan's



VISHWANIKETAN

Reg. No. F9819 - Raigad Society Reg. No. MAH/207/2012/Raigad

Corporate Office : B - 52, Sector - 12, Kharghar, Navi-Mumbai - 410210

Survey No. 52, Kumbhivali, Near Khalapur Toll Naka, off. Mumbai-Pune Expressway, Tal - Khalapur
Dist. - Raigad - Pin- 410 202 • Telephone - 02192 - 274 206/07/08/10

Dr. Ramjee Prasad
President

Dr. S. S. Inamdar
Vice - President

Mr. Sunil Bangar
Secretary



Team
TUS,2018



Team
TVUR,ITALY,2018

7.12.2018
Dr. Ramjee Prasad



VISHWANIKETAN

Reg. No. F9819 - Raigad Society Reg. No. MAH/207/2012/Raigad

Corporate Office : B - 52, Sector - 12, Kharghar, Navi-Mumbai - 410210
Survey No. 52, Kumbhivali, Near Khalapur Toll Naka, off. Mumbai-Pune Expressway, Tal - Khalapur
Dist. - Raigad - Pin- 410 202 • Telephone - 02192 - 274 206/07/08/10

Dr. Ramjee Prasad
President

Dr. S. S. Inamdar
Vice - President

Mr. Sunil Bangar
Secretary

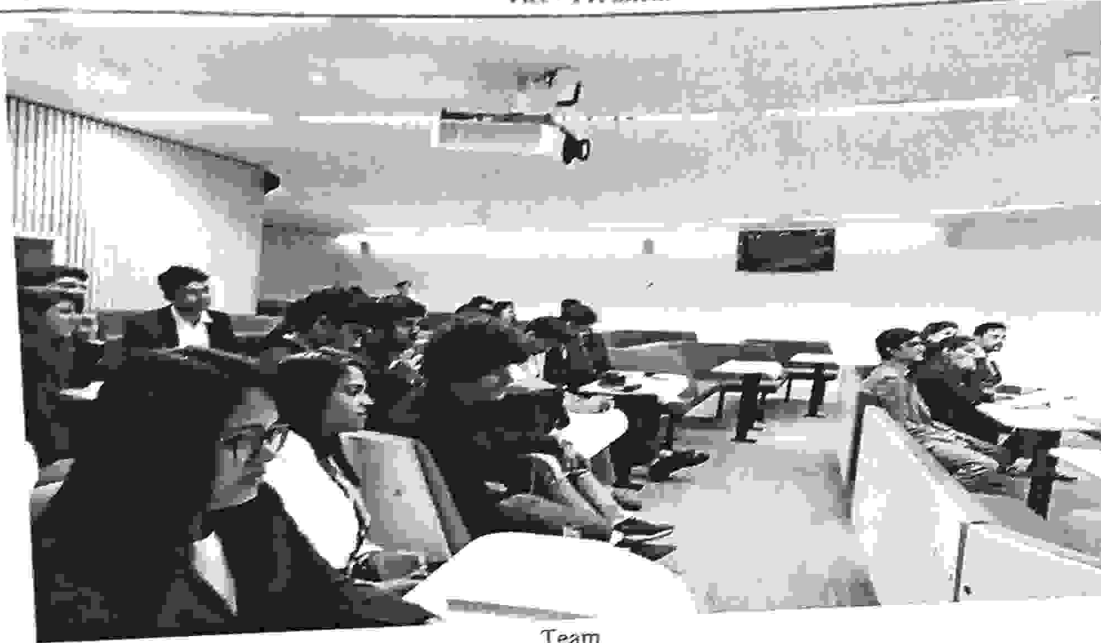

Team
Teesside, 2018



Team
URFU, 2018

TRUE COPY

[Signature]
Principal
Vishwaniketan's (i)MEET



VISHWANIKETAN

Reg. No. F9819 - Raigad Society Reg. No. MAH/207/2012/Raigad

Corporate Office : B - 52, Sector - 12, Kharghar, Navi-Mumbai - 410210

Campus : Survey No. 52, Kumbhivali, Near Khalapur Toll Naka, off. Mumbai-Pune Expressway, Tal - Khalapur
Dist. - Raigad - Pin- 410 202 - Telephone - 02192 - 274 206/07/08/10

Dr. Ramjee Prasad
President

Dr. S. S. Inamdar
Vice - President

Mr. Sunil Bangar
Secretary

Reply to Query on Metric Id 3.4.1:

Document relating the nature of collaboration and the activities of collaboration

Year: 2020

S.N.	Name of the collaborating / linking agency	Nature of collaboration	Activities of collaboration	Year of collaboration	Duration
1	Mechatol Engineering Solutions	R&D	On-the-job Training (Design of Mechanical Systems)	2020	1 Year
2	India First Robotics	R&D	On-the-job Training (Drone)	2020	6 Months
3	MOSCOS Online Services LLP	R&D	On-the-job Training (Cyber Security)	2020	6 Months
4	BITC 2104 & LD-Engineering	R&D	On-the-job Training (PLC SCADA)	2020	6 Months
5	Dnyananda Sustainables Engineering Solution	R&D	On-the-job Training (ARDUINO)	2020	6 Months
6	India First Robotics	R&D	On-the-job Training (Robotics)	2020	6 Months
7	National Technical University Ukraine Igorskirosky KPI	R&D, Cooperation, Summer research internship	Research (International Ph.D. Program)	2020	3 Years
8	European Commission	R&D	Research (CENTRAL)	2020	3 Years

TRUE COPY
Vishwaniketan's (IMEET)



VISHWANIKETAN

Reg. No. F9819 - Raigad Society Reg. No. MAH/207/2012/Raigad

Corporate Office : B - 52, Sector - 12, Kharghar, Navi-Mumbai - 410210

mpus : Survey No. 52, Kumbhivali, Near Khalapur Toll Naka, off. Mumbai-Pune Expressway, Tal - Khalapur

Dist. - Raigad - Pin- 410 202 • Telephone - 02192 - 274 206/07/08/10

Dr. Ramjee Prasad
President

Dr. S. S. Inamdar
Vice - President

Mr. Sunil Bangar
Secretary

Year: 2019

S.N.	Name of the collaborating / linking agency	Nature of collaboration	Activities of collaboration	Year of collaboration	Duration
1	Mae Fah Luang University	R&D, Cooperation, Summer research internship	UG Fellowship (Project Based Summer Internship Program at Abroad Universities)	2019	6 Weeks
2	Ural Fedral University, Russia	R&D, Cooperation, Summer research internship	UG Fellowship (Project Based Summer Internship Program at Abroad Universities)	2019	6 Weeks
3	University of Rome Tor Vegata, Italy	R&D, Cooperation, Summer research internship	UG Fellowship (Project Based Summer Internship Program at Abroad Universities)	2019	6 Weeks
4	Poznan University of Technology, Poland	R&D, Cooperation, Summer research internship	UG Fellowship (Project Based Summer Internship Program at Abroad Universities)	2019	6 Weeks
5	Athens Information Technology, Greece	R&D, Cooperation, Summer research internship	UG Fellowship (Project Based Summer Internship Program at Abroad Universities)	2019	6 Weeks
6	Tesside University, Middlesbrough	R&D, Cooperation, Summer research internship	UG Fellowship (Project Based Summer Internship Program at	2019	6 Weeks



VISHWANIKETAN

Reg. No. F0010 - Raigad Society Reg. No. MAH/207/2012/Raigad

Corporate Office : B - 52, Sector - 12, Kharghar, Navi-Mumbai - 410210

campus : Survey No. 52, Kumbhdivali, Near Khalapur Toll Naka, off. Mumbai-Pune Expressway, Tal - Khalapur
Dist. - Raigad - Pin- 410 202 * Telephone - 02192 - 274 206/07/08/10

Dr. Ranjee Prasad
President

Dr. S. S. Inamdar
Vice - President

Mr. Sunil Bangar
Secretary

7	University of Arkansas, Little Rock	R&D, Cooperation, Summer research internship	Abroad Universities) UG Fellowship (Project Based Summer Internship Program at Abroad Universities)	2019	6 Weeks
8	University of Nevada Las Vegas USA	R&D, Cooperation, Summer research internship	Abroad Universities) UG Fellowship (Project Based Summer Internship Program at Abroad Universities)	2019	6 Weeks
9	Mechatrol Engineering Solutions	R&D	On-the-job Training (Design of Mechanical Systems)	2019	1 Year
10	National Technical University Ukraine IgorSkirosky KPI	R&D, Cooperation, Summer research internship	Research (International Ph.D. Program)	2019	3 Years
11	European Commission	R&D	Research (CENTRAL)	2019	3 Years
12	Kalekar Constructions, Neral	R&D	On-the-job Training (Kalekar Constructions)	2019	6 Months
13	Zara P Care	R&D	On-the-job Training (Zara P Care)	2019	6 Months
14	BABA Automobiles, Jaipur	R&D	On-the-job Training (Electric Vehicle Design)	2019	1 Year

TRUE COPY

Signature
Vishwaniketan's (IMEET)



VISHWANIKETAN

Reg. No. F9819 - Raigad Society Reg. No. MAH/207/2012/Raigad

Corporate Office : B - 52, Sector - 12, Kharghar, Navi-Mumbai - 410210
Campus : Survey No. 52, Kumbhivali, Near Khalapur Toll Naka, off. Mumbai-Pune Expressway, Tal - Khalapur
Dist. - Raigad - Pin- 410 202 • Telephone - 02192 - 274 206/07/08/10

Dr. Ramjee Prasad
President

Dr. S. S. Inamdar
Vice - President

Mr. Sunil Bangar
Secretary

Year: 2018

S.N.	Name of the collaborating / linking agency	Nature of collaboration	Activities of collaboration	Year of collaboration	Duration
1	Technical University of Sofia, Bulgaria	R&D, Cooperation, Summer research internship	UG Fellowship (Project Based Summer Internship Program at Abroad Universities)	2018	6 Weeks
2	University of Rome Tor Vegata, Italy	R&D, Cooperation, Summer research internship	UG Fellowship (Project Based Summer Internship Program at Abroad Universities)	2018	6 Weeks
3	Ural Fedral University, Russia	R&D, Cooperation, Summer research internship	UG Fellowship (Project Based Summer Internship Program at Abroad Universities)	2018	6 Weeks
4	National Technological University Ukraine Kyiv Poletchnic	R&D, Cooperation, Summer research internship	UG Fellowship (Project Based Summer Internship Program at Abroad Universities)	2018	6 Weeks
5	Stevens Institute of Technology New Jersey USA	R&D, Cooperation, Summer research internship	UG Fellowship (Project Based Summer Internship Program at Abroad Universities)	2018	6 Weeks
6	University of Arkansas, Little Rock	R&D, Cooperation,	UG Fellowship (Project Based Summer	2018	6 Weeks



VISHWANIKETAN

Reg. No. F9819 - Raigad

Society Reg. No. MAH/207/2012/Raigad

Corporate Office : B - 52, Sector - 12, Kharghar, Navi-Mumbai - 410210
Campus : Survey No. 52, Kumbhivali, Near Khalapur Toll Naka, off. Mumbai-Pune Expressway, Tal - Khalapur
Dist. - Raigad - Pin- 410 202 • Telephone - 02192 - 274 206/07/08/10

Dr. Ramjee Prasad
President

Dr. S. S. Inamdar
Vice - President

Mr. Sunil Bangar
Secretary

		Summer research internship	Internship Program at Abroad Universities)		
7	International Technological University, San Jose	R&D, Cooperation, Summer research internship	UG Fellowship (Project Based Summer Internship Program at Abroad Universities)	2018	6 Weeks
8	Tesside University, Middlesbrough	R&D, Cooperation, Summer research internship	UG Fellowship (Project Based Summer Internship Program at Abroad Universities)	2018	6 Weeks
9	VITC, Pune		On-the-job Training (VITC)	2018	6 Months

[Handwritten signature]



VISHWANIKETAN

Reg. No. F9819 - Raigad Society Reg. No. MAH/207/2012/Raigad

Corporate Office : B - 52, Sector - 12, Kharghar, Navi-Mumbai - 410210
Survey No. 52, Kumbhivali, Near Khalapur Toll Naka, off. Mumbai-Pune Expressway, Tal - Khalapur
Dist. - Raigad - Pin- 410 202 • Telephone - 02192 - 274 206/07/08/10

Dr. Ramjee Prasad
President

Dr. S. S. Inamdar
Vice - President

Mr. Sunil Bangar
Secretary

Year: 2017

S.N.	Name of the collaborating / linking agency	Nature of collaboration	Activities of collaboration	Year of collaboration	Duration
1	Technical University of Sofia, Bulgaria	R&D, Cooperation, Summer research internship	UG Fellowship (Project Based Summer Internship Program at Abroad Universities)	2017	6 Weeks
2	Athens Information Technology, Greece	R&D, Cooperation, Summer research internship	UG Fellowship (Project Based Summer Internship Program at Abroad Universities)	2017	6 Weeks
3	University of Rome Tor Vegata, Italy	R&D, Cooperation, Summer research internship	UG Fellowship (Project Based Summer Internship Program at Abroad Universities)	2017	6 Weeks
4	Ural Fedral University, Russia	R&D, Cooperation, Summer research internship	UG Fellowship (Project Based Summer Internship Program at Abroad Universities)	2017	6 Weeks
5	Stevens Institute of Technology New Jersey USA	R&D, Cooperation, Summer research internship	UG Fellowship (Project Based Summer Internship Program at Abroad Universities)	2017	6 Weeks
6	University of Arkansas, Little Rock	R&D, Cooperation,	UG Fellowship (Project Based Summer	2017	6 Weeks

TRUE COPY

URL- www.vishwaniketan.edu.in Email- secretary@vishwaniketan.edu.in Facebook- <http://www.facebook.com/vishwaniketan.in>

Principal
Vishwaniketan's (iMEET)



VISHWANIKETAN

Reg. No. F9819 - Raigad Society Reg. No. MAH/207/2012/Raigad

Corporate Office : B - 52, Sector - 12, Kharghar, Navi-Mumbai - 410210

Survey No. 52, Kumbhivali, Near Khalapur Toll Naka, off. Mumbai-Pune Expressway, Tal - Khalapur
Dist. - Raigad - Pin- 410 202 • Telephone - 02192 - 274 206/07/08/10

Dr. Ranjee Prasad
President

Dr. S. S. Inamdar
Vice - President

Mr. Sunil Bangar
Secretary

		Summer research internship	Internship Program at Abroad Universities)		
7	National Technological University Ukraine Kyiv Poletchnic	R&D, Cooperation, Summer research internship	UG Fellowship (Project Based Summer Internship Program at Abroad Universities)	2017	6 Weeks
8	Mechatol Engineering Solutions	R&D	On-the-job Training (Design of Mechanical Systems)	2017	1 Year

TRUE COPY
Principal
Vishwaniketan's (IMEET)

MEMORANDUM
Of
UNDERSTANDING
Between
VISHWANIKETAN'S
iMEET, KUMBHIVALI
And
MECHATOL ENGINEERING
SOLUTIONS, PUNE
(Training Agency)

TRUE COPY
[Signature]
Principal
Vishwaniketan's (iMEET)

1 Executive Summary:

**Memorandum of Understanding
Between
MECHATOL ENGINEERING SOLUTIONS, PUNE
(Training Agency)
Vishwaniketan's i MEET, Kumbhivali(ViMEET)**

1.1 Context:

This MOU is hereby entered into by Vishwaniketan's i MEET Kumbhivali, Tal. Khalapur between MECHATOL ENGINEERING SOLUTIONS, PUNE here in after referred to as the training agency & the Vishwaniketan's iMEET, Kumbhivali hereinafter referred to as ViMEET collectively all signatories of this MoU will be known as cooperators.

1.2 Purpose

The Purpose of this MoU is to formalize a relationship between the a for mentioned institute & training agency for the purpose of cooperating in providing training & educational information & to facilitate the development of students towards industry readiness.

1.3 Objective

The objective of this MoU is to deliver On-Job training on DESIGN OF MECHANICAL SYSTEMS. The students of ViMEET who have enrolled for the said program will be work on industrial live problems. These training programs for ViMEET, covers the curriculum finalized between the two organizations, copies of which with signatures of both parties are enclosed to this agreement.

1.4 Training Agency & ViMEET agree to:

1. ViMEET shall provide the infrastructure for delivering the classroom sessions & lab sessions
2. Training agency shall provide competent trainers for theory & lab sessions, few specific equipment's/software will also be provided by the training agency.
3. ViMEET shall provide the stay and food arrangement of the Trainer in the institute's Hostel, at the cost as per prevailing norms of the Institute.
The installation of the software will be done by the Training agency one day prior to the training schedule.

It is mutually agreed and understood by all Parties that:

The Training agency shall follow the course content and Timetable will be provided by ViMEET. Refer Appendix I & II for pre-requisites and project respectively.

TRUE COPY
[Signature]
Principal
Vishwaniketan's (iMEET)

2 2.1 Contact Details:

College:

Dr. B. R. Patil
Principal
Vishwaniketan's i MEET,
Kumbhivali.

Training Agency:

Mr. Anand Bhise,
MECHATOL ENGINEERING
SOLUTIONS, Kothrud, PUNE (411038)

3 3.1 1.1.1 Commencement /Expiration/Termination:

This MoU takes effect upon the signature of the training agency & VIMEET and shall remain in effect for the particular course from date of execution which will be valid for 01 Year (One Year). This MOU may be extended or amended upon written request of the training agency & subsequent with concurrence of the other party. Any of the parties may terminate this MOU with 30 days written notice to the other party.

3.3 Methodology:

Feedback: The training agency may take feedback of the participants as & when they feel necessary. ViMEET will take feedback from students on regular basis & will inform the trainers about the outcome of the feedback. The suggestions evolved out of this feedback will be MANDATORY on the part of trainers.

3.4 Project:

After completion of the training the training agency must provide a good quality project for each student in the group of (3-4) students and it evaluated by the Industry Experts. It is the sole responsibility of the training agency that 95% students must complete the project.

After completion of training, the training agency shall provide the support for solving the problems for completion of project by skype meeting/ Email exchange/ telephonic discussion/college visit.

The trainer must review the project (by physical presence at Vishwaniketan's iMEET, Khalapur Campus) at least twice in the semester (The dates will be finalized mutually agreed on).

3.5 Examination and Certificate:

Project Exhibition for evaluation of projects will be conducted after completion of the course delivery & project. Certificates will be provided by training agency & ViMEET to all participants. The evaluation scheme will be as follows:

- 20% Marks course learning
- 30% Marks Assignment and Attendance
- 50% Marks -Project

TRUE COPY

Principal
Vishwaniketan's iMEET





3.6 Certificates and Awards:

Successful candidates will receive a "Course Completion Certificate" Signed by ViMEET & training agency. The Certificates will be issued by Training Agency.

4 4.1 Payment Disbursement:

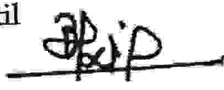
1. 50% of the total amount shall be paid to training agency after 2 week from the date of successful completion of the basic training of said On-Job training Program.
2. 25% after the second Visit of trainer to review the project progress of students.
3. 25% after successful completion of VAP exhibition in the EVEN semester.
4. In case of unsatisfactory conduction of Projects, the payment done by ViMEET will be given back proportionately in consultation.

Signature:

Principal, ViMEET, Khalapur Name: Dr. B. R. Patil  Date: 06/06/2020	Authorized signatory of Training Agency Name: Mr. Anand Bhise  Date: 06/06/2020
Witnesses	
1. Name: Dr. S. B. Kadam Sign: 	2. Name: Mr. Vaibhav Ajmire Sign: 

TRUE COPY



Appendix I

Pre-requisite :

**Students should know basic knowledge of Solidworks software,
Topics as follows,**

Software Name	Topic
Solidworks	<ol style="list-style-type: none">1. Introduction to solidworks modelling2. Tool used in solidworks modelling3. Introduction to solidworks assembly4. Tool used in solidworks assembly5. Hands on practicals.6. Tools to solidworks sheet metal7. Introduction to solidworks sheetmetal.8. Hands on practicals on solidworks sheetmetal.9. Introduction to solidworks structure.10. Tools to solidworks structure11. Hands on practicals on solidworks structure.12. Introduction to solidworks drawing.13. Hands on practicals on solidworks drawing.

1

TRUE COPY
Vishwanath
MEET

Appendix II

Projects

S/No.	Title
1	Special purpose machine
2	Belt Conveyer
3	Automotives
4	Injection Moulding
5	Material Handling System

TRUE COPY
[Signature]
[Stamp]

Memorandum
Of
Understanding
Between
Vishwaniketan's
i MEET, Kumbhivali

And
India FIRST Robotics
Innovation & Research LLP.
Pune

TRUE COPY

Principal
Vishwaniketan's (iMEET)

Executive Summary**Memorandum of Understanding****India FIRST Robotics Innovation & Research LLP, Pune****And****Vishwaniketan's i MEET, Kumbhivali(ViMEET)****1.1 Context**

This MOU is hereby entered into by **Vishwaniketan's i MEET Kumbhivali, Tal. Khalapur** between **India FIRST Robotics Innovation & Research LLP Pune** hereinafter referred to as the training agency & the Vishwaniketan's iMEET, Kumbhivali hereinafter referred to as ViMEET collectively all signatories of this MoU will be known as cooperators.

1.2 Purpose

The Purpose of this MoU is to formalize a relationship between the aforementioned institute & training agency for the purpose of cooperating in providing training & educational information & to facilitate the development of students towards industry readiness.

1.3 Objective

The objective of this MOU is to deliver training on Drone Technology to the students of ViMEET, who have enrolled for the said Value Addition Program (VAP). Training program for ViMEET, covers the curriculum finalized between the two organizations, copies of which with signatures of both parties are enclosed to this agreement.

1.4 1.1 Training Agency & ViMEET agree to (Offline):

1. Training agency shall provide competent trainers for offline theory & lab sessions, few specific software will also be provided by the training agency.
2. The installation of the software will be done by the Training agency one day prior to the training schedule.

It is mutually agreed and understood by all Parties that:

The Training agency shall follow the course content and Time Table provided by ViMEET which are attached as Appendix I & II respectively.

TRIAL COPY
2024-25-26 (PROJECT)

2 2.1 Contact Details :

College:

Dr Vikas Shinde
Director,
PBL Centre of Excellence,
Vishwaniketan's iMEET,
Kumbhivali
Phone: 9762051751

Training Agency:

India FIRST Robotics Innovation &
Research LLP, Pune

3 3.1 1.1.1 Commencement /Expiration/Termination

This MoU takes effect upon the signature of the training agency & VIMEET and shall remain in effect for the particular course from date of execution. This MOU may be extended or amended upon written request of the training agency & subsequent with concurrence of the other party. Any of the parties may terminate this MOU with 30 days written notice to the other party.

3.2 1.1.2 Program Duration & Time Slot.

Course Name	Duration	Batch Size(No. of Students)
Robotics (First Year Engineering)	6 MONTHS	18

3.3 Methodology

Feedback: The training agency may take feedback of the participants as & when they feel necessary. ViMEET will take feedback from students on regular basis & will inform the trainers about the outcome of the feedback. The suggestions evolved out of this feedback will be MANDATORY on the part of trainers.

3.4 Project

After completion of the training the training agency must provide a good quality project for each student in the group of (5-6) students and it should be evaluated by the Industry Trainer. It is the sole responsibility of the training agency that 95% students must complete the project.

After completion of training, the training agency shall provide the support for solving the problems for completion of project by skype meeting/Email exchange/ telephonic discussion.

The trainer must review the project (by physical presence at Vishwaniketan's iMEET, Khalapur Campus) at least twice in the semester. (The dates will be finalized mutually agreed on)

3.5 Examination and Certificate

Project Exhibition for evaluation of projects will be conducted after completion of the course delivery & project. Certificates will be provided by training agency to all participants.

TRUE COPY

Vishwaniketan's (iMEET)

3.6 Certificates

Successful candidates will receive a "Course Completion Certificate" signed & training agency. The Certificates will be issued by Training Agency.

4 4.1 Fees

The Fees charged by the Training agency INR 3500.00 per student. This fee will be is inclusive of all taxes.

The Training agency will charge INR 3500.00 per students and Four percent of the total batch size of the students to economically backward categories will be given training free. ViMEET¹ will provide the listing of students.

5 5.1 Payment Disbursement

1. 50% of the total amount shall be paid to training agency at the End of the Program.
2. 25% After the First Visit of trainer to see the project progress of students.
3. 25% after successful completion of VAP exhibition in the same semester.
4. In case of unsatisfactory conduction of Value Addition Program (VAP), the payment done by ViMEET will be given back proportionately in consultation.

Signature:

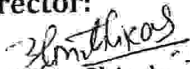
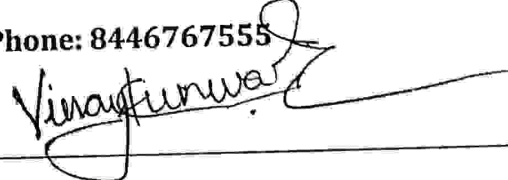
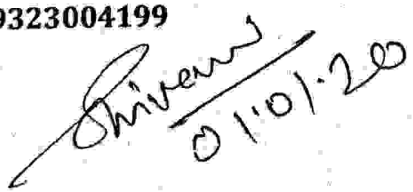
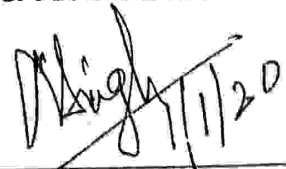
Director:  Dr Vikas Shinde Director, PBL Centre of Excellence, Vishwaniketan's i MEET, Kumbhivali Phone : 9762051751	Authorized signatory of Training Agency: India FIRST Robotics Innovation & Research LLP. Pune Phone: 8446767555 
Witnesses	
1.Name: Shivani Agrawal HOD Department of First Year Engineering Phone: 9323004199  01/01/20	1.Name: Dr. Nidhi Singh Faculty Cordinator Department of First Year Engineering Phone: 9890123561  11/1/20

TRUE COPY

Principal
Vishwaniketan's (iMEET)

Appendix I

COURSE CONTENT: - Drone Technology

Detailed Syllabus of the Course:

Session 01: Aerodynamic.

- ✓ Introduction to UAV
- ✓ Introduction to Flight
- ✓ Fundamental of Aerodynamics
- ✓ Introduction to Avionics
- ✓ Airplane Performance and Design
- ✓ Micro-controller & Embedded Systems

Session 02: Control System.

- ✓ Mathematical Modelling & Simulation
- ✓ Flight Instrumentation & Data Acquisition System
- ✓ Automatic Flight Control
- ✓ Flight Stability & Control
- ✓ Path planning and Obstacle Avoidance for Unmanned Vehicles
- ✓ Actuators and Sensors for UAV

Session 03: Design and Development of Drone.

- ✓ Basic Fundamentals of AUW (All up Weight)
- ✓ Drone Development Life Cycle.
- ✓ Lift vs Thrust Calculations.
- ✓ Details about Drone Parts.
- ✓ Assembly and Design of Drone.
- ✓ Flight in Test Mode for Stability Check.

Session 04: Design and Development of Payload Carrier Drone.

- ✓ Drone Development Life Cycle.
- ✓ AUW (All Up weight) Calculation for payload.
- ✓ Design and Assembly of payload carrier Drone.
- ✓ Test Mode Flight for Stability Check.
- ✓ And payload Check for Pendulum Effect.

Session 05: Hands on Drone Simulation.

- ✓ Introduction to Lab Flight Modes and Techniques
- ✓ Head Free Mode
- ✓ Head Less Mode
- ✓ Stabilize mode.
- ✓ Altitude hold Mode.
- ✓ Land Mode.
- ✓ Loiter Mode.
- ✓ RTL | RTH mode.

Session 06: Live Practice on Drone Flying and Flying Techniques.

- ✓ Head Free Mode
- ✓ Head Less Mode
- ✓ Stabilize mode.
- ✓ Altitude hold Mode.
- ✓ Land Mode.
- ✓ Loiter Mode.
- ✓ RTL | RTH mode.

Appendix II

Time Table for Academic Year 2019-20

Date	Day
06.01.2020	Monday
07.01.2020	Tuesday
08.01.2020	Wednesday
09.01.2020	Thursday
10.01.2020	Friday
11.01.2020	Saturday

Timings : **09.00AM to 12.40PM (First Session)**
12.40PM to 01.40PM (Lunch Break)
01.40PM to 05.00PM (Second Session)

PROJECTS

S/No.	Title
1	Remote Controlled Security & Alert System using Drone Technology
2	Automatic Life Detection System using thermal imaging for UVA
3	Automatic Land Mapping System using UVA
4	Automatic LiDAR based 3D mapping system for 3D imaging
5	Automatic Seed Sowing Drone for the payload of 100 grams
6	Automatic Package Delivery Drone
7	Automatic Object Tracking Drone
8	UAV based intrusion Detection System for Border Areas
9	Automatic Path Planning Drone using ROS
10	Pesticide spraying drone for the payload of 2KG approx.

TRUE COPY

Vishy
Project
Team's (IMEET)

Memorandum

Of

Understanding

Between

Vishwaniketan's

i MEET, Kumbhivali

And

MOSCOS Online Services LLP,

Pune

TRINIC

 Vishwaniketan

1

Executive Summary

Memorandum of Understanding

Between MOSCOS Online Services LLP

And

Vishwaniketan's i MEET, Kumbhivali(ViMEET)

1.1 Context

This MOU is hereby entered into by Vishwaniketan's i MEET Kumbhivali, Tal. Khalapur between MOSCOS Online Services LLP, Pune. hereinafter referred to as the training agency & the Vishwaniketan's iMEET, Kumbhivali hereinafter referred to as ViMEET collectively all signatories of this MoU will be known as cooperators.

1.2 Purpose

The Purpose of this MoU is to formalize a relationship between the aforementioned institute & training agency for the purpose of cooperating in providing training & educational information & to facilitate the development of students towards industry readiness.

1.3 Objective

The objective of this MoU is to deliver training on the technology specifically mentioned like IOT with Python, Machine Learning, Business Analytics, and Business Intelligence etc. to the students of ViMEET who have enrolled for the said value-addition program. These training programs for ViMEET, covers the curriculum finalized between the two organizations, copies of which with signatures of both parties are enclosed to this agreement.

1.4 Training Agency & ViMEET agree to:

1. ViMEET shall provide the infrastructure for delivering the classroom sessions & lab sessions
2. Training agency shall provide competent trainers for theory & lab sessions, few specific equipment's/software will also be provided by the training agency.
3. ViMEET shall provide the stay and food arrangement of the Trainer in the institute's Hostel, at the cost as per prevailing norms of the Institute.
4. The installation of the software will be done by the Training agency one day prior to the training schedule.

It is mutually agreed and understood by all Parties that:

The Training agency shall follow the course content and Time Table provided by ViMEET which are attached as Appendix I & II respectively.

2 2.1 Contact Details :

College:
Dr. B. R. Patil
Principal,
Vishwaniketan's iMEET,
Kumbhivali
Phone : 02192-274208

Training Agency:

MOSCOS Online Services LLP, Pune
Phone: 7387236939

TRUE COPY
(Signature)
Principal
Vishwaniketan's (iMEET)

3.1 **Commencement /Expiration/Termination**
 This MoU takes effect upon the signature of the training agency & ViMEET and shall remain in effect for the particular course from date of execution. This MOU may be extended or amended upon written request of the training agency & subsequent with concurrence of the other party. Any of the parties may terminate this MOU with 30 days written notice to the other party.

3.2 **Program Duration & Time Slot.**

Course Name	Duration	Batch Size(No. of Students)
Cyber Security (TE-EXTC)	6 Days	29

3.3 **Methodology**
Feedback: The training agency may take feedback of the participants as & when they feel necessary. ViMEET will take feedback from students on regular basis & will inform the trainers about the outcome of the feedback. The suggestions evolved out of this feedback will be MANDATORY on the part of trainers.

3.4 **Project**
 After completion of the training the training agency must provide a good quality project for each student in the group of (3-4) students and it evaluated by the Industry Experts. It is the sole responsibility of the training agency that 95% students must complete the project.
 After completion of training, the training agency shall provide the support for solving the problems for completion of project by skype meeting/Email exchange/ telephonic discussion.
 The trainer must review the project (by physical presence at Vishwaniketan's iMEET, Khalapur Campus) at least twice in the semester. (The dates will be finalized mutually agreed on)

3.5 **Examination and Certificate**
 Project Exhibition for evaluation of projects will be conducted after completion of the course delivery & project. Certificates will be provided by training agency & ViMEET to all participants. The evaluation scheme will be as follows:
 20% Marks course learning
 30% Marks Assignment and Attendance
 50% Marks – Project

3.6 **Certificates and Awards**
 Successful candidates will receive a "Course Completion Certificate" Signed by ViMEET & training agency. The Certificates will be issued by Training Agency.



4.1 **Fees**
 The Fees charged by the Training agency, INR 2600.00 per student. This fee will be is inclusive of all taxes. The Training agency will charge INR 2400.00 per student.

TRUE COPY
 Vishwaniketan's (ViMEET)

5 5.1 Payment Disbursement

1. 50% of the total amount shall be paid to training agency at the end of the Program.
2. 25% after the First Visit of trainer to see the project progress of students.
3. 25% after successful completion of VAP exhibition in the same semester.
4. In case of unsatisfactory conduction of Value Addition Program (VAP), the payment done by ViMEET will be given back proportionately in consultation.

Signature:

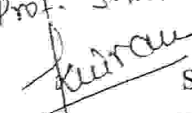
<p>Principal</p> <p></p> <p>Name: Dr. B. R. Patil Date: 25/01/2020</p>	<p>Authorized signatory of Training Agency</p> <p></p> <p>Name: Mr. Narayan Swami Date: 25/01/2020</p>
<p>Witnesses</p> <p>Dr. Vikas Shinde Prof. S. S. Wagh </p> <p>Sign</p>	<p>Prof. Sandeep Linge Prof. J. K. Hirani </p> <p>Sign</p>



Principal
Vishwaniketan's (iMEET)

Memorandum
Of
Understanding
Between
Vishwaniketan's
i MEET, Kumbhivali
And
Ditap-V Automation Pvt. Ltd., Pune.
&
BITC 2104, Pune.
(Training Agency)

TRUE COPY
[Signature]
Principal
Vishwaniketan's (iMEET)

1

Executive Summary

Memorandum of Understanding

Ditap-V Automation Pvt. Ltd / BITC 2104, Pune

And

Vishwaniketan's i MEET, Kumbhivali(ViMEET)

1.1 Context

This MoU is hereby entered into by Vishwaniketan's i MEET Kumbhivali, Tal. Khalapur between Ditap-V Automation Pvt. Ltd / BITC 2104, Pune hereinafter referred to as the training agency & the Vishwaniketan's iMEET, Kumbhivali hereinafter referred to as ViMEET collectively all signatories of this MoU will be known as cooperators.

1.2 Purpose

The Purpose of this MoU is to formalize a relationship between the aforementioned institute & training agency for the purpose of cooperating in providing training & educational information & to facilitate the development of students towards industry readiness.

1.3 Objective

The objective of this MoU is to deliver training on automation technology based on PLC / SCADA / DCS / Control Panels to the students of ViMEET who have enrolled for the said value-addition program. These training programs for ViMEET, covers the curriculum finalized between the two organizations, copies of which with signatures of both parties are enclosed to this agreement.

1.4 Training Agency & ViMEET agree to:

1. ViMEET shall provide the infrastructure for delivering the classroom sessions & lab sessions
2. Training agency shall provide competent trainers for theory & lab sessions, the specific instruments, hardware, simulators and software will also be provided by the training agency.
3. ViMEET shall provide the stay and food arrangement of the Trainer in the institute's Hostel, at the cost as per prevailing norms of the Institute.
4. The installation of the software will be done by the Training agency one day prior to the training schedule.

It is mutually agreed and understood by all Parties that:

The Training agency shall follow the course content and Time Table provided by ViMEET which are attached as Appendix I & II respectively.

2 2.1 Contact Details :

College:

Dr Janhavi Inamdar
Director,
Vishwaniketan's i MEET,
Kumbhivali
Phone : 02192-274208

Training Agency:

Mr Omprakash N Barure
Director,
Software Services & Training
Ditap-V Automation Pvt. Ltd. / BITC 2104, Pune
Phone: 9322122789

3 3.1 **Commencement /Expiration/Termination**

This MoU takes effect upon the signature of the training agency & ViMEET and shall remain in effect for the particular course from date of execution. This MoU may be extended or amended upon written request of the training agency & subsequent with concurrence of the other party. Any of the parties may terminate this MOU with 30 days written notice to the other party.

3.2 **Program Duration & Time Slot:**

Course Name	Duration	Batch Size(No. of Students)
TE (Electrical)	6 Days	30

3.3 **Methodology**

Feedback: The training agency may take feedback of the participants as & when they feel necessary. ViMEET will take feedback from students on regular basis & will inform the trainers about the outcome of the feedback. The suggestions evolved out of this feedback will be MANDATORY on the part of trainers.

3.4 **Project**

After completion of the training the training agency must provide a good quality project for each student in the group of (3-4) students and is evaluated by the Industry Experts. It is the sole responsibility of the training agency that 95% students must complete the project.

After completion of training, the training agency shall provide the support for solving the problems for completion of project by Skype meeting/Email exchange/ telephonic discussion.

The trainer must review the project (by physical presence at Vishwaniketan's iMEET, Khalapur Campus) at least twice in the semester.(The dates will be finalized with mutual agreement)

3.5 **Examination and Certificate**

Project Exhibition for evaluation of projects will be conducted after completion of the course delivery & project. Certificates will be provided by training agency & ViMEET to all participants. The evaluation scheme will be as follows:

- 20% Marks course learning
- 30% Marks Assignment and Attendance
- 50% Marks -Project

3.6 **Certificates and Awards**

Successful candidates will receive a "Course Completion Certificate" Signed by ViMEET & training agency. The Certificates will be issued by Training Agency.

4 4.1 **Fees**

The Fees charged by the Training agency INR 2200.00 per student. This fee will be inclusive of all taxes.

The Training agency will charge INR 2200.00 per students and Four percent of the total batch size of the students belonging to economically backward categories will be given FREE training. ViMEET will provide the listing of students.





5 5.1 **Payment Disbursement**

TRUE COPY

Principal
Vishwaniketan's (iMEET)

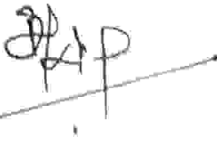
1. 50% of the total amount shall be paid to training agency at the End of the Program.
2. 25% after the First Visit of trainer to see the project progress of students.
3. 25% after successful completion of VAP exhibition in the same semester.
4. In case of unsatisfactory conduction of Value Addition Program (VAP), the payment done by ViMEET will be given back proportionately in consultation.

Signature:

<p>Principal</p>  <p>Name: Dr. B. R. Patil</p> <p>Date: 15/07/2019</p>	<p>Authorized signatory of Training Agency For BITC 2104</p>  <p>Proprietor</p> <p>Name: Mr. Omprakash N. Barure</p> <p>Date: 15/07/2019</p>
<p>Principal Vishwaniketan's (ViMEET)</p>	
<p>Witnesses</p>	
<p>1. Name Vishwabhav A. Ajmire VAP coordinator ViMEET</p> <p>Sign </p>	<p>2. Name Joshi S. K. Asst. Professor, ViMEET</p> <p>Sign </p>



TRUE COPY



15/07/2019

MEMORANDUM
Of
UNDERSTANDING
Between
**VISHWANIKETAN'S
iMEET, KUMBHIVALI**
And
**Dnyanada Sustainable
Engineering Solutions Pvt.
Ltd.**
(Training Agency)

TRUE COPY
[Signature]
Principal
Vishwaniketan's (iMEET)

1

Executive Summary:

Memorandum of Understanding

Between

**IndiaFIRST(R) Robotics Innovation and Research LLP Dnyanada
Sustainable Engineering Solutions Pvt. Ltd.**

(Training Agency)

Vishwaniketan's i MEET, Kumbhivali(ViMEET)

1.1 Context:

This MOU is hereby entered into by
Vishwaniketan's i MEET Kumbhivali, Tal. Khalapur
between

Dnyanada Sustainable Engineering Solutions Pvt. Ltd.

hereinafter referred to as the training agency & the Vishwaniketan's
iMEET, Kumbhivali hereinafter referred to as ViMEET collectively all
signatories of this MoU will be known as cooperators.

1.2 Purpose

The Purpose of this MoU is to formalize a relationship between the a for
mentioned institute & training agency for the purpose of cooperating in providing
training & educational information & to facilitate the development of students
towards industry readiness.

1.3 Objective

The objective of this MoU is to On-Job project/training which having involment
of the technologies specifically mentioned like Robotics, Automation
,C,ASP.NET, JAVA, Ansys, Catia, Mat Lab, AutoCAD, Solid works etc. to the
students of ViMEET who have enrolled for the said value-addition program.
These On-Job training programs for ViMEET, covers the curriculum finalized
between the two organizations, copies of which with signatures of both parties are
enclosed to this agreement.

1.4 Training Agency & ViMEET agree to:

1. ViMEET shall provide the infrastructure for delivering the classroom
sessions & lab sessions
2. Training agency shall provide competent trainers for theory & lab sessions,
few specific equipment's/software will also be provided by the training
agency.
3. ViMEET shall provide the stay and food arrangement of the Trainer in the
institute's Hostel, at the cost as per prevailing norms of the Institute.
The installation of the software will be done by the Training agency one
day prior to the training schedule.

It is mutually agreed and understood by all Parties that:

The Training agency shall follow the course content and Time Table provided by
ViMEET which are attached as Appendix I & II respectively.

TRUE COPY

BY: [Signature] [Name] [Title]

2 2.1 Contact Details:

College:

Dr. B. R. Patil
Principal,
Vishwaniketan's iMEET,
Kumbhivali.

Training Agency:

Mrs. Shilpa V. Shinde
Dnyanada Sustainable Engineering
Solutions Pvt. Ltd.

3 3.1 1.1.1 Commencement/Expiration/Termination:

This MoU takes effect upon the signature of the training agency & ViMEET and shall remain in effect for the particular course from date of execution which will be valid for 6 Months (SIX Months). This MOU may be extended or amended upon written request of the training agency & subsequent with concurrence of the other party. Any of the parties may terminate this MOU with 30 days written notice to the other party.

3.2 Methodology:

Feedback: The training agency may take feedback of the participants as & when they feel necessary. ViMEET will take feedback from students on regular basis & will inform the trainers about the outcome of the feedback. The suggestions evolved out of this feedback will be MANDATORY on the part of trainers.

3.3 Project:

After completion of the training the training agency must provide a good quality project for each student in the group of (3-4) students and it evaluated by the Industry Experts. It is the sole responsibility of the training agency that 95% students must complete the project. After completion of training, the training agency shall provide the support for solving the problems for completion of project by skype meeting/Email exchange/ telephonic discussion/college visit. The trainer must review the project (by physical presence at Vishwaniketan's iMEET, Khalapur Campus) at least twice in the semester (The dates will be finalized mutually agreed on).

3.4 Examination and Certificate:

Project Exhibition for evaluation of projects will be conducted after completion of the course delivery & project. Certificates will be provided by training agency & ViMEET to all participants. The evaluation scheme will be as follows:

- 20% Marks course learning
- 30% Marks Assignment and Attendance
- 50% Marks -Project

3.5 Certificates and Awards:

Successful candidates will receive a "Course Completion Certificate" Signed by ViMEET & training agency. The Certificates will be issued by Training Agency.

4.1 Payment Disbursement if any:

1. 50% of the total amount shall be paid to training agency after 2 week from the date of successful completion of the VAP training Program.
2. 25% after the second Visit of trainer to review the project progress of students.
3. 25% after successful completion of VAP exhibition in the same semester.
4. In case of unsatisfactory conduction of On-Job Training, the payment done by ViMEET will be given back proportionately in consultation.

Signature:

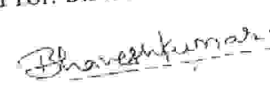
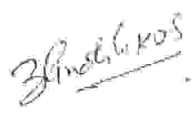
<p>Principal ViMEET, Khalapur</p> <p></p> <p>Name: Dr. B.R. Patil Date: 07/07/2020</p>	<p>Authorized signatory of Training Agency</p> <p></p> <p>Name: Mrs. Shilpa V. Shinde Date: 07/07/2020</p>
<p>Witnesses</p> <p>1. Name: Prof. B.N. Pasi</p> <p>Sign: </p>	<p>2. Name: Dr. Vikas Shinde</p> <p>Sign: </p>

TRUE COPY

Principal
Vishwaniketan's (ViMEET)

MEMORANDUM

Of

UNDERSTANDING

Between

**VISHWANIKETAN'S
iMEET, KUMBHIVALI**

And

**IndiaFIRST(R) Robotics Inno-
vation and Research LLP
(Training Agency)**

TRUE COPY
Principal
VISHWANIKETAN'S (iMEET)

1 Executive Summary:

Memorandum of Understanding
Between
IndiaFIRST(R) Robotics Innovation and Research LLP
(Training Agency)
Vishwaniketan's i MEET, Kumbhivali(ViMEET)

1.1 Context:

This MOU is hereby entered into by Vishwaniketan's i MEET Kumbhivali, Tal. Khalapur between IndiaFIRST(R) Robotics Innovation and Research LLP hereinafter referred to as the training agency & the Vishwaniketan's iMEET, Kumbhivali hereinafter referred to as ViMEET collectively all signatories of this MoU will be known as cooperators.

1.2 Purpose

The Purpose of this MoU is to formalize a relationship between the aforementioned institute & training agency for the purpose of cooperating in providing training & educational information & to facilitate the development of students towards industry readiness.

1.3 Objective

The objective of this MoU is to deliver On-Job training on the specifically mentioned like Robotics, Automotion, C,ASP.NET, JAVA, Ansys, Catia, MatLab, AutoCAD, Solid works etc. to the students of ViMEET who have enrolled for the said On-Job Training program. These training programs for ViMEET, covers the curriculum finalized between the two organizations, copies of which with signatures of both parties are enclosed to this agreement.

1.4 Training Agency & ViMEET agree to:

1. ViMEET shall provide the infrastructure for delivering the classroom sessions & lab sessions
2. Training agency shall provide competent trainers for theory & lab sessions, few specific equipment's/software will also be provided by the training agency.
3. ViMEET shall provide the stay and food arrangement of the Trainer in the institute's Hostel, at the cost as per prevailing norms of the Institute.
The installation of the software will be done by the Training agency one day prior to the training schedule.

It is mutually agreed and understood by all Parties that:

The Training agency shall follow the course content and Time Table provided by ViMEET which are attached as Appendix I & II respectively.

TRUE COPY

Principal
Vishwaniketan's (iMEET)

2 2.1 Contact Details:

College:

Dr. B. R. Patil
Principal,
Vishwaniketan's iMEET,
Kumbhivali.

Training Agency:

Mr. Ajinkya Jadhav
Technical- BDM
IndiaFIRST ROBOTICS

3 3.1 1.1.1 Commencement /Expiration/Termination:

This MoU takes effect upon the signature of the training agency & ViMEET and shall remain in effect for the particular course from date of execution which will be valid for 01 Year (ONE Year). This MOU may be extended or amended upon written request of the training agency & subsequent with concurrence of the other party. Any of the parties may terminate this MOU with 30 days written notice to the other party.

3.2 Methodology:

Feedback: The training agency may take feedback of the participants as & when they feel necessary. ViMEET will take feedback from students on regular basis & will inform the trainers about the outcome of the feedback. The suggestions evolved out of this feedback will be MANDATORY on the part of trainers.

3.3 Project:

After completion of the basic training the training agency must provide a good quality project for each student in the group of (3-4) students and it evaluated by the Industry Experts. It is the sole responsibility of the training agency that 95% students must complete the project.

After completion of training, the training agency shall provide the support for solving the problems for completion of project by skype meeting/Email exchange/ telephonic discussion/college visit.

The trainer must review the project (by physical presence at Vishwaniketan's iMEET, Khalapur Campus) at least twice in the semester (The dates will be finalized mutually agreed on).

3.4 Examination and Certificate:

Project Exhibition for evaluation of projects will be conducted after completion of the course delivery & project. Certificates will be provided by training agency & ViMEET to all participants. The evaluation scheme will be as follows:

- 20% Marks course learning
- 30% Marks Assignment and Attendance
- 50% Marks -Project

INDIAFIRST ROBOTICS
Mr. Ajinkya Jadhav
Technical- BDM
IndiaFIRST ROBOTICS

3.6 Certificates and Awards:



Successful candidates will receive a "Course Completion Certificate" Signed by ViMEET & training agency. The Certificates will be issued by Training Agency.

11)

Signature:

U grant,
ith your

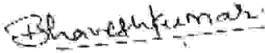
relosed
express
dress.

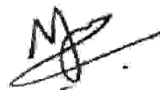
HoD, Mechanical Engg. Dept., ViMEET, Khalapur Name: Prof. B.N. Pasi  Date: 09/05/2020	Authorized signatory of Training Agency Name: Mr. Vinay Kunvar / Ajinkya Jadhav  Date: 09/05/2020
Witnesses	
1. Name: Dr. Vikas V. Shinde Sign: 	2. Name: Prof. V.A.Ajmire Sign: 

our
our

ed
te
+

g
e
s
i

TRUE COPY

Principal
Vishwaniketan's (iMEET)

Education, Audiovisual and Culture Executive Agency



Erasmus+ - Higher Education - International Capacity Building

Brussels, 10 DEC. 2018
Appfin 29028204
File code: 18-3767

Brian Bech Nielsen
AARHUS UNIVERSITET
NORDRE RINGGADE 1,
DK-8000 AARHUS C

Subject: Project number: 598914-EPP-1-2018-1-DK-EPPKA2-CBHE-JP (2018 - 3767 / 001 - 001)

Dear Sir/Madam,

Following our email, confirming that your above mentioned proposal has been selected to receive an EU grant, please find enclosed the Grant Agreement (including eight Annexes) which the Agency is ready to sign with your institution.

I would be grateful if you as the *legal representative* of your institution could sign two copies of the enclosed Agreement, initial each page, including each page of the Annexes. Both copies have to be returned by express registered mail and reach the Agency within seven working days of the date of this letter to the following address:

Education, Audiovisual and Culture Executive Agency (EACEA)
Mr Ralf RAHDERS
Head of Unit A4
Office: J-59 04/ 033
1, Avenue du Bourget
1049 Brussels
Belgium

One copy of the Grant Agreement, signed by both parties, will be returned to you.

Please note, that the eligibility period for the reimbursement of costs starts, as indicated in Article 1.2.2 of your Grant Agreement, on 15 January 2019. Only costs incurred during the eligibility period may be claimed in your financial statements.

It is important to note, that with the signature of the grant agreement not all the activities and the costs planned under the awarded maximum project budget are automatically approved by the Agency. Before starting the project's activities, you should therefore carefully check them against the Grant Agreement and the Erasmus+ Programme Guide.

Finally, on 28-29 January 2019 the Agency will organise a meeting in Brussels with all the Capacity Building projects selected under the 2018 Call for Proposals. During this meeting, you will be provided with valuable information on the management of your project and you will have the opportunity to meet the Agency colleagues in charge of your project as well as other important stakeholders of the Erasmus+ our programme. Detailed information on the precise location and participation conditions will be sent to you by the end of the year 2018.

Please note that if we do not receive the Grant Agreement duly signed within seven working days of the date of this letter, or if we find any modification to the text of the Agreement or its Annexes, the Agency may no longer be in a position to accept and sign the Grant Agreement.

If you have been asked to provide a bank guarantee, please be aware that, by derogation to article 11.24.1, when the co-ordinator is established in a Partner Country, a bank or a financial institution established in that Partner Country may provide the guarantee.

Education, Audiovisual and Culture Executive Agency (EACEA)
Office: J-59 04/ 033- BE-1049 Brussels - Belgium
Phone: (32-2) 299.49.15 - Fax: (32-2) 299.45.30
http://eacea.ec.europa.eu/erasmus-plus_en
E-mail: EACEA-EPLUS-CBHE-PROJECTS@ec.europa.eu

TRUE COPY
[Signature]

5

Education, Audiovisual and Culture Executive Agency



Erasmus+ - Higher Education - International Capacity Building

Brussels, 10 DEC. 2018
Appfin 490 288204
File code: 18-3767

Brian Bech Nielsen
AARHUS UNIVERSITET
NORDRE RINGGADE 1,
DK-8000 AARHUS C

Subject: Project number: 598914-EPP-1-2018-1-DK-EPPKA2-CBHE-JP (2018 - 3767 / 001 - 001)

Dear Sir Madam,

Following our email, confirming that your above mentioned proposal has been selected to receive an EU grant, please find enclosed the Grant Agreement (including eight Annexes) which the Agency is ready to sign with your institution.

I would be grateful if you as the legal representative of your institution could sign two copies of the enclosed Agreement, initial each page, including each page of the Annexes. Both copies have to be returned by express registered mail and reach the Agency within seven working days of the date of this letter to the following address:

Education, Audiovisual and Culture Executive Agency (EACEA)
Mr Ralf RAHDERS
Head of Unit A4
Office: J-59 04/ 033
1, Avenue du Bourget
1049 Brussels
Belgium

One copy of the Grant Agreement, signed by both parties, will be returned to you.

Please note, that the eligibility period for the reimbursement of costs starts, as indicated in Article 1.2.2 of your Grant Agreement, on 15 January 2019. Only costs incurred during the eligibility period may be claimed in your financial statements.

It is important to note, that with the signature of the grant agreement not all the activities and the costs planned under the awarded maximum project budget are automatically approved by the Agency. Before starting the project's activities, you should therefore carefully check them against the Grant Agreement and the Erasmus+ Programme Guide.

Finally, on 28-29 January 2019 the Agency will organise a meeting in Brussels with all the Capacity Building projects selected under the 2018 Call for Proposals. During this meeting, you will be provided with valuable information on the management of your project and you will have the opportunity to meet the Agency colleagues in charge of your project as well as other important stakeholders of the Erasmus+ our programme. Detailed information on the precise location and participation conditions will be sent to you by the end of the year 2018.

Please note that if we do not receive the Grant Agreement duly signed within seven working days of the date of this letter, or if we find any modification to the text of the Agreement or its Annexes, the Agency may no longer be in a position to accept and sign the Grant Agreement.

If you have been asked to provide a bank guarantee, please be aware that, by derogation to article 11.24.1, when the co-ordinator is established in a Partner Country, a bank or a financial institution established in that Partner Country may provide the guarantee.

Education, Audiovisual and Culture Executive Agency (EACEA)
Office: J-59 04/ 033- BE-1049 Brussels - Belgium
Phone: (32-2) 299 49 15 - Fax: (32-2) 299 45 30
http://eacea.ec.europa.eu/erasmus-plus_en
E-mail: EACEA-PLUS-CBHE-PROJES@ec.europa.eu

TRUE COPY
[Signature]

In closing, I wish you every success with your project and look forward to fruitful collaboration and positive results.

Yours sincerely,



Ralf RAHDERS
Head of Unit

Encl.: Grant Agreement including eight Annexes

Cc: Project coordinator

TRUE COPY

Official
Signature (MESH)



Education, Audiovisual and Culture Executive Agency

Erasmus+: Higher Education - International Capacity Building

GRANT AGREEMENT FOR AN ACTION WITH MULTIPLE BENEFICIARIES

Mixed financing (reimbursement based on percentage of eligible costs and lump sum(s) and/or unit contribution(s))

AGREEMENT NUMBER – 2018 - 3767 / 001 - 001

Project reference number - 598914-EPP-1-2018-1-DK-EPPKA2-CBHE-JP

The Education, Audiovisual and Culture Executive Agency (hereinafter referred to as “the Agency”), acting under powers delegated by the European Commission (hereinafter referred to as “the Commission”) represented for the purposes of signature of this Agreement by Mr Ralf Rahders Head of Unit Erasmus+; Higher Education - International Capacity Building,

on the one part,

and

AARHUS UNIVERSITET
NORDRE RINGGADE 1,
DK - 8000 AARHUS C

hereinafter referred to as “the coordinator”, represented for the purposes of signature of this Agreement by **Brian Bech Nielsen**

and the beneficiaries listed in Annex IV duly represented by the coordinator by virtue of the mandates included in Annex IV for the signature of this Agreement, hereinafter referred to collectively as “the beneficiaries”, and individually as “beneficiary” for the purposes of this Agreement where a provision applies without distinction between the coordinator or another beneficiary,

on the other part,

Whereas the Commission has taken a decision n° C(2013)8550 of 04/12/2013 as amended by decision n° C(2016)5719 of 13/09/2016 and n° C(2014)6158 of 03/09/2014 as amended by decision n° C(2016)5753 of 13/09/2016 authorizing the use of lump sums, reimbursement on the basis of unit costs and flat-rate under the Erasmus+ Programme;

TRUE COPY
[Signature]
Principal
Vishwaniketan's (IMEET)

HAVE AGREED

to the Special Conditions (hereinafter referred to as "the Special Conditions") and the following Annexes:

- Annex I Description of the action
- Annex II General Conditions (hereinafter referred to as "the General Conditions")
- Annex III Estimated budget of the action
- Annex IV List of beneficiaries (and affiliated entities if applicable) and Mandates provided to the coordinator by the other beneficiaries
- Annex V Model Technical report
- Annex VI Model Financial statement
- Annex VII Guidance notes – Report of Factual Findings on the Final Financial Report – Type II
- Annex VIII Model terms of reference for the operational verification report: not applicable

which form an integral part of this Agreement, hereinafter referred to as "the Agreement".

The terms set out in the Special Conditions shall take precedence over those set out in the Annexes.

The terms of Annex II "General Conditions" shall take precedence over the other Annexes.

TRUE COPY
31
Vishwanath's (IMEET)

SPECIAL CONDITIONS

ARTICLE I.1 – SUBJECT MATTER OF THE AGREEMENT

A European Union grant is awarded, under the terms and conditions set out in the Special Conditions, the General Conditions and the other Annexes to the Agreement, for the action entitled **Capacity building and Exchange towards attaining Technological Research and modernizing Academic Learning** ("the action") as described in Annex I.

With the signature of the Agreement, the beneficiaries accept the grant and agree to implement the action, acting on their own responsibility.

ARTICLE I.2 – ENTRY INTO FORCE OF THE AGREEMENT AND DURATION OF THE ACTION

I.2.1 The Agreement shall enter into force on the date on which the last party signs.

I.2.2 The action shall run for **36 months** as of **15-01-2019** ("the starting date of the action") and shall end on **14-01-2022**.

ARTICLE I.3 - MAXIMUM AMOUNT AND FORM OF THE GRANT

The grant shall be of a maximum amount of **EUR 1.000.000,00** and shall take the form of:

(a) The reimbursement of 100 % of the eligible costs of the action ("reimbursement of eligible costs"), which are:

(i) actually incurred ("reimbursement of actual costs") for the following categories of costs indicated in Annex III: Equipment costs, Costs for Subcontracting and Exceptional costs

(ii) reimbursement of unit costs: not applicable

(iii) reimbursement of lump sum costs: not applicable

(iv) declared on the basis of a flat-rate of 7 % of the eligible direct costs ("reimbursement of flat rate costs") to cover the indirect costs: not applicable

(b) A unit contribution to cover the following categories of eligible costs indicated in Annex III: Staff Costs, Travel Costs and Costs of Stay

(c) Lump sum[s] contribution: not applicable

(d) Flat-rate contribution: not applicable.

ARTICLE I.4 – ADDITIONAL PROVISIONS ON REPORTING, PAYMENTS AND PAYMENT ARRANGEMENTS

I.4.1 Reporting periods, payments and additional supporting documents

In addition to the provisions set out in Articles II.23 and II.24, the following reporting and payment arrangements shall apply:

TRUE COPY

Principal
Withhold 20% (NAEET)

- Upon entry into force of the Agreement, a pre-financing payment of 50 % of the maximum amount specified in Article I.3 shall be paid to the coordinator.

Progress report on implementation of the action

- By way of derogation from Article II.23.1 paragraph 3, a "progress report on implementation of the action" as specified in Annex V shall be submitted at the latest half way through the eligibility period set out in Article I.2.2.

Further pre-financing payment

- By way of derogation from Article II.23.1 paragraph 3, a second pre-financing payment of 40 % of the maximum amount specified in Article I.3 shall be paid to the coordinator, subject to the following conditions:
 - o having used at least 70 % of the previous pre-financing instalment paid;
 - o the receipt of the "Statement on the use of the previous pre-financing instalment", as specified in Annex VI, and the Request for payment;
 - o the receipt of the above-mentioned "progress report on implementation of the action" as specified in Annex V.

Payment of the balance

- Sole reporting period from 15-01-2019 to the end of the period set out in Article I.2.2.: the balance shall be paid to the coordinator, in accordance with Article II.23.2 (a) to (c) and all other accompanying documents mentioned under the section "Other supporting documents" of this Article.

Other supporting documents

The request for payment of the balance shall be accompanied by a certificate on the financial statements and underlying accounts ("Report of Factual Findings on the Final Financial Report – Type II") as set out in Annex VII. By way of derogation from Article II.23.2 (d) of the General Conditions, this certificate has to be provided in all cases regardless the amount indicated as total contribution in the form of reimbursement of actual costs as referred to in Article I.3.

I.4.2 Time limit for payments

The time limit for the Agency to make the payment of the balance is 60 days.

I.4.3 Language of requests for payments, technical reports and financial statements

All requests for payments, technical reports and financial statements shall be submitted in English, French or German, preferably in English, indicating the number of the Agreement and the Project reference number.

TRUE COPY

Principal
(IMEET)

TRUE COPY
Principal
Vishwaniketan's (IMEET)

ARTICLE 1.5 – BANK ACCOUNT FOR PAYMENTS

All payments shall be made to the coordinator's bank account, denominated in euro¹, as indicated below:

Name of bank: **DANSKE BANK A/S**
Address of branch: **2-12, HOLMENS KANAL,
DK - COPENHAGEN**
Precise denomination of the account holder: **AARHUS UNIVERSITET**
IBAN account number (including bank codes): **IBAN _ONLY**
IBAN code: **DK8502164069053238**

ARTICLE 1.6 - DATA CONTROLLER AND COMMUNICATION DETAILS OF THE PARTIES

1.6.1 Data controller

The entity acting as a data controller according to Article 11.6 shall be the person who is representing the Agency for the purposes of the signature of this Agreement.

1.6.2 Communication details of the Agency

Any communication addressed to the Agency shall be sent to the following address:

Education, Audiovisual and Culture Executive Agency
Mr Ralf Rahders
Unit A4 - Erasmus+: Higher Education - International Capacity Building
Office: J-59 04/ 033
1, Avenue du Bourget
BE-1049 Brussels

Any communication addressed by e-mail to the Agency shall be sent to the functional mailbox (FACEA-EPLUS-CBHE-PROJECTS@ec.europa.eu) AND to the Project Officer in charge.

1.6.3 Communication details of the beneficiaries

Any communication from the Agency to the beneficiaries shall be sent to the following address:

Ramjee Prasad
AARHUS UNIVERSITET
NORDRE RINGGADE 1,
DK - 8000 AARHUS C

TRUE COPY

Principal
Vishwaniketan's (IMEET)

¹ Except in the case of bank accounts in countries that do not accept euro transactions.

ARTICLE I.7 – ADDITIONAL PROVISIONS ON USE OF THE RESULTS (INCLUDING INTELLECTUAL AND INDUSTRIAL PROPERTY RIGHTS)

In addition to the provisions of Article II.8 of the General Conditions, if the beneficiaries produce materials under the scope of the project, such materials must be made available for the public, in digital form, freely accessible through the Internet under open licenses.

The beneficiaries must also warrant that the Agency and the European Union has the rights to:

- communicate the results of the action by any other types of communication not specified in the General Conditions;
- edit or re-write in another way the results of the action, including shortening, summarising, modifying the content, correcting technical errors in the content;
- cut, insert meta-data, legends or other graphic, visual, audio or word elements in the results of the action;
- extract a part (e.g. audio or video files) of, divide into parts or compile the results of the action;
- prepare derivative works of the results of the action;
- translate, insert subtitles in, dub the results of the action in all official languages of EU;
- authorise or sub-licence the modes of exploitation set out above to third parties;

The Agency and the European Union shall have the rights of use specified in the General Conditions and set out above for the whole duration of the industrial or intellectual property rights concerned.

ARTICLE I.8 – SPECIAL PROVISIONS ON BUDGET TRANSFERS

By way of derogation from the first subparagraph of Article II.22 of the General Conditions, the coordinator may, in agreement with the beneficiaries, when carrying out the action, adjust the estimated budget by transfers between categories of eligible costs, provided that this adjustment of expenditure does not affect the implementation of the action and the transfer between categories does not exceed 10% of the amount of each category of estimated eligible costs for which the transfer is intended, and without exceeding the total eligible costs indicated in Article I.3.

ARTICLE I.9 – SETTLEMENT OF DISPUTES WITH NON EU BENEFICIARIES

By way of derogation from Article II.18.2, where a beneficiary is legally established in a country other than a Member State of the European Union (the 'non EU beneficiary'), the Agency and/or the Union and/or the non EU beneficiary may bring before the Courts of Brussels any dispute between the Agency and/or the Union and the non EU beneficiary concerning the interpretation, application or validity of the Agreement, if such dispute cannot be settled amicably. In such case where one party (i.e. the Agency, the Union or the non EU beneficiary) has brought proceedings before the Courts of Brussels concerning the interpretation, application or validity of the Agreement, the other party may not bring a claim arising from the interpretation, application or validity of the Agreement in any other court than the Courts of Brussels already seized.

TRUE COPY
Priyanka
Mishra (MIEFT)

ARTICLE 1.10 – OTHER SPECIAL CONDITIONS

The following additional special conditions apply to this Agreement:

I.10.1 Additional provisions on award of contracts and subcontracting

In addition to the provisions set out in Article II.9 and Article II.10 of the General Conditions, where the value of a contract awarded in accordance with those Articles is over EUR 25.000 and less than EUR 134.000, the beneficiaries shall launch a tendering procedure and obtain competitive offers from at least three suppliers and retain the one offering best value for money, observing the principles of transparency and equal treatment of potential contractors and taking care to avoid conflicts of interests. Where the value of a contract awarded in accordance with those Articles exceeds EUR 134.000, national legislation will be applicable.

The beneficiaries may not split the purchase of equipment into smaller contracts below the threshold. The co-ordinator must clearly document the tendering procedure and retain the documentation in particular for audit purposes in accordance with Article II.27 of the General Conditions.

I.10.2 Special provisions on the conversion of costs incurred in another currency into euro

By way of derogation from Article II.23.4 of the General Conditions, any conversion into euro of actual costs incurred in other currencies shall be made by the beneficiary at the monthly accounting rate established by the Commission and published on its website (http://ec.europa.eu/budget/contracts_grants/info_contracts/infoeuro/infoeuro_en.cfm) applicable:

1. on the month of the first pre-financing for all costs incurred until the second pre-financing is received and
2. on the month of the receipt of the second pre-financing for all costs incurred until the end of the project.

I.10.3 Depreciation

By way of derogation from Article II.19.2 (c) of the General Conditions, and considering the particular nature of the Erasmus+ Programme - Capacity Building in the field of higher education, the total purchase cost of the equipment will be taken into account by the Agency rather than the equipment's depreciation corresponding to the duration of the action and the rate of actual use for the purposes of the action. Depreciation costs shall be considered ineligible.

I.10.4 Ineligible costs

In addition to Article II.19.4 of the General Conditions, the following costs are ineligible:

- equipment such as: furniture, motor vehicles of any kind, equipment for research and development purposes, telephones, mobile phones, alarm systems and anti-theft systems;
- costs of premises (purchase, rent, heating, maintenance, repairs etc.);
- costs linked to the purchase of real estate;
- expenses for activities - and related travel - that are not carried out in the project beneficiaries' country (see Annex IV), unless listed as an eligible activity in the Guidelines for the Use of the Grant or explicit prior authorisation has been granted by the Agency;
- depreciation costs (see Art.I.10.3).

TRUE COPY
 20
 Principal
 Vishwaniketan's (IMEET)

I.10.5 Partnership agreement

Detailed implementation modalities covering the various financial, technical and legal aspects of the project must be agreed upon by the beneficiaries and formalised in a partnership agreement to be signed by all beneficiaries at the beginning of the project.

This partnership agreement should be consistent with the provisions as laid out in this Agreement. The Agency provides a template with core elements that might help to draw this partnership agreement.

A signed copy of this partnership agreement will have to be provided by e-mail to the Agency within 6 months of the signature of this Agreement. Where the beneficiaries have failed to submit this partnership agreement, the provisions set out in Article II.16.3.1 (c) of the General Conditions will apply.

I.10.6 Penalties in the case of poor, partial or late implementation

For the purpose of poor, partial or late implementation as provided for in Article II.25.4 of the General Conditions, and in a total of maximum 100 points, the reduction of the grant will be of:

- 25% if the project scores at least 40 points and below 50 points;
- 35% if the project scores at least 30 and below 40 points;
- 55% if the project scores at least 20 and below 30 points;
- 75% if the project scores below 20 points.

I.10.7 Meetings

Representatives of the co-ordinator (and other beneficiaries if required) shall participate in meetings organised by the Agency. There will be up to 2 meetings per year. The expenses for participation will be considered eligible costs.

I.10.8 Dissemination and exploitation of results

Beneficiaries of grants under the Erasmus+ programme have the duty to ensure that the work undertaken within the framework of this Grant Agreement and the results accruing from it receive substantial visibility.

The co-ordinator must pay specific attention to the importance of dissemination, exploitation of results of the action and to their visibility at a transnational level.

In this respect, the coordinator must:

- create and maintain (at least during the project lifetime) a website for the action. The website must be kept up-to-date with at least: a description of the project, the contact details of the co-ordinator, the list of beneficiaries, mention of the European Union's financial support with the relevant logo (see Article I.10.9 below) and access to all results, as and when they become available.
- provide during the project lifetime the Agency and/or the Commission with the information requested in order to promote the Erasmus+ Programme and disseminate the results. This may include answering questionnaires and entering data into databases.

TRUE COPY

[Signature]
Principal
Vishwanath's (IMEET)

- update the project summary in accordance with the instructions provided in Annex V².
- use the Erasmus+ Project Results Platform, on the website <http://ec.europa.eu/programmes/erasmus-plus/projects/> to disseminate and exploit project results and deliverables in accordance with the instructions provided therein. The approval of the final report will be subject to the upload of the project results/deliverables on the aforementioned Platform by the time of its submission.

I.10.9 Publicity obligations

1. For the purpose of Article II.7 of the grant agreement, relating to the publicity and use of the relevant logo, the beneficiaries must follow the instructions available on the following website: https://eacea.ec.europa.eu/about-eacea/visual-identity_en
2. The beneficiaries must inform the public, press and media of the action (internet included), which must, in conformity with Article II.7 mentioned above, visibly indicate “with the support of the Erasmus+ Programme of the European Union” as well as the graphic logos.
3. Where the action, or part of the action, is a publication, the mention and graphic logos must appear on the cover or the first pages following the editor's mention.
4. If the action includes events for the public, signs and posters related to this action must be displayed. This must include the logos mentioned under point 1. Authorisation to use the logos described in point 1 implies no right of exclusive use and is limited to this agreement.

I.10.10 Penalties in the case of non-compliance with publicity obligations

The obligation to comply with the publicity provision set out in Article II.7 of the General Conditions constitutes a substantial obligation. Without prejudice to the right to terminate the grant, in case of failure to fulfil this obligation, the Agency may apply a 20% reduction of the grant initially provided for.

I.10.11 Cooperation obligation

Considering that the Agency cooperates with some bodies for the management of the Erasmus+ Programme, in particular with the EU Delegations and for those countries concerned the National Erasmus+ Offices (NEO), the beneficiaries shall provide these bodies with all the information relevant for the implementation of the tasks entrusted to them and shall grant access to their sites, premises and documents for any question relating to the action.

TRUE COPY

Principal
Vishwaniketan's (IMEET)

² Model Technical report

L10.12 Regional coverage

In accordance with EU policy, this Agreement shall not apply to the geographic areas that came under the administration of the State of Israel after 5th June 1967. This position should not be construed as prejudicing Israel's principled position on this matter. Accordingly, the Parties agree that the application of this Agreement is without prejudice to the status of those areas.

SIGNATURES

For the coordinator
Brian Bech Nielsen
Function:

For the Agency
Ralf RAHDERS
Head of Unit

Signature
Done at date

Signature
Done at Brussels,

In duplicate in English

TRUE COPY
(Handwritten signature)
Vishwanathan's (IMEET)

ANNEX I

Description of the action

The grant awarded aims at implementing the Action as submitted by the Coordinator and registered under the reference number:

598914-EPP-1-2018-1-DK-EPPKA2-CBHE-JP

TRUE COPY

Kriszta
Vasvári Jókai
Köznevelési és
Kulturális Minisztérium

ANNEX II

General Conditions

TRUE COPY

Vishw... 's (IMEET)

ANNEX II
GENERAL CONDITIONS

TABLE OF CONTENT

PART A – LEGAL AND ADMINISTRATIVE PROVISIONS

- II.1 – GENERAL OBLIGATIONS AND ROLES OF THE BENEFICIARIES
- II.2 – COMMUNICATIONS BETWEEN THE PARTIES
- II.3 – LIABILITY FOR DAMAGES
- II.4 – CONFLICT OF INTERESTS
- II.5 – CONFIDENTIALITY
- II.6 – PROCESSING OF PERSONAL DATA
- II.7 – VISIBILITY OF UNION FUNDING
- II.8 – PRE-EXISTING RIGHTS AND OWNERSHIP AND USE OF THE RESULTS (INCLUDING INTELLECTUAL AND INDUSTRIAL PROPERTY RIGHTS)
- II.9 – AWARD OF CONTRACTS NECESSARY FOR THE IMPLEMENTATION OF THE ACTION
- II.10 – SUBCONTRACTING OF TASKS FORMING PART OF THE ACTION
- II.11 – FINANCIAL SUPPORT TO THIRD PARTIES
- II.12 – AMENDMENTS TO THE AGREEMENT
- II.13 – ASSIGNMENT OF CLAIMS FOR PAYMENTS TO THIRD PARTIES
- II.14 – FORCE MAJEURE
- II.15 – SUSPENSION OF THE IMPLEMENTATION OF THE ACTION
- II.16 – TERMINATION OF THE AGREEMENT
- II.17 – ADMINISTRATIVE AND FINANCIAL PENALTIES
- II.18 – APPLICABLE LAW, SETTLEMENT OF DISPUTES AND ENFORCEABLE DECISION

PART B – FINANCIAL PROVISIONS

II.19 – ELIGIBLE COSTS

II.20 – IDENTIFIABILITY AND VERIFIABILITY OF THE AMOUNTS DECLARED

II.21 – ELIGIBILITY OF COSTS OF ENTITIES AFFILIATED TO THE BENEFICIARIES

II.22 – BUDGET TRANSFERS

II.23 – TECHNICAL AND FINANCIAL REPORTING – REQUESTS FOR PAYMENT AND SUPPORTING DOCUMENTS

II.24 – PAYMENTS AND PAYMENT ARRANGEMENTS

II.25 – DETERMINING THE FINAL AMOUNT OF THE GRANT

II.26 – RECOVERY

II.27 – CHECKS, AUDITS AND EVALUATION

TRUE COPY

Principal
Vision... (UNICEF)

PART A – LEGAL AND ADMINISTRATIVE PROVISIONS

ARTICLE II.1 – GENERAL OBLIGATIONS AND ROLES OF THE BENEFICIARIES

II.1.1 General obligations and role of the beneficiaries

The beneficiaries shall:

- (a) be jointly and severally responsible for carrying out the action in accordance with the terms and conditions of the Agreement;
- (b) be responsible for complying with any legal obligations incumbent on them jointly or individually;
- (c) make appropriate internal arrangements for the proper implementation of the action, consistent with the provisions of this Agreement; where provided for in the Special Conditions, these arrangements shall take the form of an internal co-operation agreement between the beneficiaries.

II.1.2 General obligations and role of each beneficiary

Each beneficiary shall:

- (a) inform the coordinator immediately of any change likely to affect or delay the implementation of the action of which the beneficiary is aware;
- (b) inform the coordinator immediately of any change in its legal, financial, technical, organisational or ownership situation or of its affiliated entities and of any change in its name, address or legal representative or of its affiliated entities;
- (c) submit in due time to the coordinator:
 - (i) the data needed to draw up the reports, financial statements and other documents provided for in the Agreement;
 - (ii) all the necessary documents in the event of audits, checks or evaluation in accordance with Article II.27;
 - (iii) any other information to be provided to the Agency according to the Agreement, except where the Agreement requires that such information is submitted directly by the beneficiary to the Agency.

II.1.3 General obligations and role of the coordinator

The coordinator shall:

- (a) monitor that the action is implemented in accordance with the Agreement;
- (b) be the intermediary for all communications between the beneficiaries and the Agency, except where provided otherwise in the Agreement, and, in particular, the coordinator shall:
 - (i) immediately provide the Agency with the information related to any change in the name, address, legal representative as well as in the legal, financial, technical, organisational or ownership situation of any of the beneficiaries or of its affiliated entities or to any event likely to affect or delay the implementation of the action, of which the coordinator is aware;

- (ii) bear responsibility for supplying all documents and information to the Agency which may be required under the Agreement, except where provided otherwise in the Agreement; where information is required from the other beneficiaries, the coordinator shall bear responsibility for obtaining and verifying this information before passing it on to the Agency;
- (c) make the appropriate arrangements for providing any financial guarantees required under the Agreement;
- (d) establish the requests for payment in accordance with the Agreement;
- (e) where it is designated as the sole recipient of payments on behalf of all of the beneficiaries, ensure that all the appropriate payments are made to the other beneficiaries without unjustified delay;
- (f) bear responsibility for providing all the necessary documents in the event of checks and audits initiated before the payment of the balance, and in the event of evaluation in accordance with Article II.27;
- (g) transfer to the beneficiaries, without delay, any document relating to the action or the grant.

The coordinator shall not subcontract any part of its tasks to the other beneficiaries or to any other party.

ARTICLE II.2 – COMMUNICATIONS BETWEEN THE PARTIES

II.2.1 Form and means of communications

Any communication relating to the Agreement or to its implementation shall be made in writing (in paper or electronic form), shall bear the number of the Agreement and shall be made using the communication details identified in Article I.6.

Electronic communications shall be confirmed by an original signed paper version of that communication if requested by any of the parties provided that this request is submitted without unjustified delay. The sender shall send the original signed paper version without unjustified delay.

Formal notifications shall be made by registered mail with return receipt or equivalent, or by equivalent electronic means.

II.2.2 Date of communications

Any communication is deemed to have been made when it is received by the receiving party, unless the agreement refers to the date when the communication was sent.

Electronic communication is deemed to have been received by the receiving party on the day of successful dispatch of that communication, provided that it is sent to the addressees listed in Article I.6. Dispatch shall be deemed unsuccessful if the sending party receives a message of non-delivery. In this case, the sending party shall immediately send again such communication to any of the other addresses listed in Article I.6. In case of unsuccessful dispatch, the sending party shall not be held in breach of its obligation to send such communication within a specified deadline.

Mail sent to the Agency using the postal services is considered to have been received by the Agency on the date on which it is registered by the department identified in Article I.6.2.

Formal notifications made by registered mail with return receipt or equivalent, or by equivalent electronic means, shall be considered to have been received by the receiving party on the date of receipt indicated on the return receipt or equivalent.

ARTICLE II.3 – LIABILITY FOR DAMAGES

- II.3.1** The Agency shall not be held liable for any damage caused or sustained by any of the beneficiaries, including any damage caused to third parties as a consequence of or during the implementation of the action.
- II.3.2** Except in cases of force majeure, the beneficiaries shall compensate the Agency for any damage sustained by it as a result of the implementation of the action or because the action was not implemented or implemented poorly, partially or late

ARTICLE II.4 - CONFLICT OF INTERESTS

- II.4.1** The beneficiaries shall take all necessary measures to prevent any situation where the impartial and objective implementation of the Agreement is compromised for reasons involving economic interest, political or national affinity, family or emotional ties or any other shared interest (“conflict of interests”).
- II.4.2** Any situation constituting or likely to lead to a conflict of interests during the implementation of the Agreement shall be notified to the Agency, in writing, without delay. The beneficiaries shall immediately take all the necessary steps to rectify this situation. The Agency reserves the right to verify that the measures taken are appropriate and may require additional measures to be taken within a specified deadline.

ARTICLE II.5 – CONFIDENTIALITY

- II.5.1** The Agency and the beneficiaries shall preserve the confidentiality of any information and documents, in any form, which are disclosed in writing or orally in relation to the implementation of the Agreement and which are explicitly indicated in writing as confidential.
- II.5.2** The beneficiaries shall not use confidential information and documents for any reason other than fulfilling their obligations under the Agreement, unless otherwise agreed with the Agency in writing.
- II.5.3** The Agency and the beneficiaries shall be bound by the obligations referred to in Articles II.5.1 and II.5.2 during the implementation of the Agreement and for a period of five years starting from the payment of the balance, unless:
- (a) the party concerned agrees to release the other party from the confidentiality obligations earlier;
 - (b) the confidential information becomes public through other means than in breach of the confidentiality obligation through disclosure by the party bound by that obligation;
 - (c) the disclosure of the confidential information is required by law.

ARTICLE II.6 – PROCESSING OF PERSONAL DATA**II.6.1 Processing of personal data by the Agency**

Any personal data included in the Agreement shall be processed by the Agency pursuant to Regulation (EC) No 45/2001 of the European Parliament and of the Council of 18 December 2000 on the protection of individuals with regard to the processing of personal data by the Community institutions and bodies and on the free movement of such data.

Such data shall be processed by the data controller identified in Article I.6.1 solely for the purposes of the implementation, management and monitoring of the Agreement, without prejudice to possible transmission to the bodies charged with the monitoring or inspection tasks in application of Union law.

The beneficiaries shall have the right of access to their personal data and the right to rectify any such data. Should the beneficiaries have any queries concerning the processing of their personal data, they shall address them to the data controller, identified in Article I.6.1.

The beneficiaries shall have the right of recourse at any time to the European Data Protection Supervisor.

II.6.2 Processing of personal data by the beneficiaries

The beneficiaries must process personal data under the Agreement in compliance with applicable EU and national law on data protection (including authorisations or notification requirements).

The beneficiaries may grant their personnel access only to data that is strictly necessary for implementing, managing and monitoring the Agreement.

The beneficiaries must adopt appropriate technical and organisational security measures having regard to the risks inherent in the processing and to the nature of the personal data concerned. This is in order to:

- (a) prevent any unauthorised person from gaining access to computer systems processing personal data, and especially:
 - (i) unauthorised reading, copying, alteration or removal of storage media;
 - (ii) unauthorised data input as well as any unauthorised disclosure, alteration or erasure of stored personal data;
 - (iii) unauthorised use of data processing systems by means of data transmission facilities;
- (b) ensure that authorised users of a data processing system can access only the personal data to which their access right refers;
- (c) record which personal data have been communicated, when and to whom;
- (d) ensure that personal data processed on behalf of third parties can be processed only in the manner prescribed by the Agency;
- (e) ensure that, during communication of personal data and transport of storage media, the data cannot be read, copied or erased without authorisation;
- (f) design their organisational structure in such a way that it meets data protection requirements.

TRUE COPY
[Signature]

ARTICLE II.7 – VISIBILITY OF UNION FUNDING

II.7.1 Information on Union funding and use of European Union emblem

Unless the Agency requests or agrees otherwise, any communication or publication related to the action, made by the beneficiaries jointly or individually, including at conferences, seminars or in any information or promotional materials (such as brochures, leaflets, posters, presentations, etc.), shall indicate that the action has received funding from the Union and shall display the European Union emblem.

When displayed in association with another logo, the European Union emblem must have appropriate prominence.

The obligation to display the European Union emblem does not confer to the beneficiaries a right of exclusive use. The beneficiaries shall not appropriate the European Union emblem or any similar trademark or logo, either by registration or by any other means.

For the purposes of the first, second and third subparagraphs and under the conditions specified therein, the beneficiaries are exempted from the obligation to obtain prior permission from the Agency to use the European Union emblem.

II.7.2 Disclaimers excluding Agency and Commission responsibility

Any communication or publication related to the action, made by the beneficiaries jointly or individually in any form and using any means, shall indicate that it reflects only the author's view and that the Agency and the Commission are not responsible for any use that may be made of the information it contains.

ARTICLE II.8 – PRE-EXISTING RIGHTS AND OWNERSHIP AND USE OF THE RESULTS (INCLUDING INTELLECTUAL AND INDUSTRIAL PROPERTY RIGHTS)

II.8.1 Ownership of the results by the beneficiaries

Unless stipulated otherwise in the Agreement, ownership of the results of the action, including industrial and intellectual property rights, and of the reports and other documents relating to it, shall be vested in the beneficiaries.

II.8.2 Pre-existing industrial and intellectual property rights

Where industrial and intellectual property rights, including rights of third parties, exist prior to the conclusion of the Agreement, the beneficiaries shall establish a list which shall specify all rights of ownership and use of the pre-existing industrial and intellectual property rights and disclose it to the Agency at the latest before the commencement of implementation.

The beneficiaries shall ensure that they or their affiliated entities have all the rights to use any pre-existing industrial and intellectual property rights during the implementation of the Agreement.

II.8.3 Rights of use of the results and of pre-existing rights by the Agency and/or the Union

Without prejudice to Articles II.1.1, II.3 and II.8.1, the beneficiaries grant the Agency and/or the Union the right to use the results of the action for the following purposes:

- (a) use for its own purposes, and in particular, making available to persons working for the Agency, the Union institutions, agencies and bodies and to Member States' institutions, as well as, copying and reproducing in whole or in part and in unlimited number of copies;

ARTICLE II.10 – SUBCONTRACTING OF TASKS FORMING PART OF THE ACTION

- II.10.1** A **Subcontract** is a procurement contract within the meaning of Article II.9, which covers the implementation by a third party of tasks forming part of the action as described in Annex I.
- II.10.2** Beneficiaries may subcontract tasks forming part of the action, provided that, in addition to the commitment specified in Article II.9 and the Special Conditions, the following conditions are complied with:
- (a) subcontracting only covers the implementation of a limited part of the action;
 - (b) recourse to subcontracting is justified having regard to the nature of the action and what is necessary for its implementation;
 - (c) the estimated costs of the subcontracting are clearly identifiable in the estimated budget set out in Annex III;
 - (d) any recourse to subcontracting, if not provided for in Annex I, is communicated by the coordinator and approved by the Agency without prejudice to Article II.12.2;
 - (e) the beneficiaries ensure that the conditions applicable to them under Article II.7 are also applicable to the subcontractor.

ARTICLE II.11 - FINANCIAL SUPPORT TO THIRD PARTIES

- II.11.1** Where the implementation of the action requires giving financial support to third parties, the beneficiaries shall give such financial support in accordance with the conditions specified in Annex I, which shall at least contain:
- (a) the maximum amount of financial support, which shall not exceed EUR 60 000 for each third party except where the financial support is the primary aim of the action as specified in Annex I;
 - (b) the criteria for determining the exact amount of the financial support;
 - (c) the different types of activity that may receive financial support, on the basis of a fixed list;
 - (d) the definition of the persons or categories of persons which may receive financial support;
 - (e) the criteria for giving the financial support.
- II.11.2** By way of derogation from Article II.11.1, in case the financial support takes the form of a prize, the beneficiaries shall give such financial support in accordance with the conditions specified in Annex I, which shall at least contain:
- (a) the conditions for participation;
 - (b) the award criteria;
 - (c) the amount of the prize;
 - (d) the payment arrangements.

TAKE COPY

- II.11.3 The beneficiaries shall ensure that the conditions applicable to them under Articles II.3, II.4, II.5, II.7, II.8 and II.27 are also applicable to the third parties receiving financial support.

ARTICLE II.12 – AMENDMENTS TO THE AGREEMENT

- II.12.1 Any amendment to the Agreement shall be made in writing.
- II.12.2 An amendment may not have the purpose or the effect of making changes to the Agreement which would call into question the decision awarding the grant or be contrary to the equal treatment of applicants.
- II.12.3 Any request for amendment shall be duly justified and shall be sent to the other party in due time before it is due to take effect, and in any case one month before the end of the period set out in Article I.2.2, except in cases duly substantiated by the party requesting the amendment and accepted by the other party.
- II.12.4 A request for amendment on behalf of the beneficiaries shall be submitted by the coordinator. If a change of coordinator is requested without its agreement, the request shall be submitted by all other beneficiaries.
- II.12.5 Amendments shall enter into force on the date on which the last party signs or on the date of approval of the request for amendment.

Amendments shall take effect on a date agreed by the parties or, in the absence of such an agreed date, on the date on which the amendment enters into force.

ARTICLE II.13 – ASSIGNMENT OF CLAIMS FOR PAYMENTS TO THIRD PARTIES

- II.13.1 Claims for payments of the beneficiaries against the Agency may not be assigned to third parties, except in duly justified cases where the situation warrants it.

The assignment shall only be enforceable against the Agency if it has accepted the assignment on the basis of a written and reasoned request to that effect made by the coordinator on behalf of the beneficiaries. In the absence of such acceptance, or in the event of failure to observe the terms thereof, the assignment shall have no effect on the Agency.

- II.13.2 In no circumstances shall such an assignment release the beneficiaries from their obligations towards the Agency.

ARTICLE II.14 – FORCE MAJEURE

- II.14.1 "Force majeure" shall mean any unforeseeable exceptional situation or event beyond the parties' control, which prevents either of them from fulfilling any of their obligations under the Agreement, which was not attributable to error or negligence on their part or on the part of subcontractors, affiliated entities or third parties involved in the implementation and which proves to be inevitable in spite of exercising all due diligence. Any default of a service, defect in equipment or material or delays in making them available, unless they stem directly from a relevant case of force majeure, as well as labour disputes, strikes or financial difficulties cannot be invoked as *force majeure*.
- II.14.2 A party faced with *force majeure* shall formally notify the other party without delay, stating the nature, likely duration and foreseeable effects.
- II.14.3 The parties shall take the necessary measures to limit any damage due to *force majeure*. They shall do their best to resume the implementation of the action as soon as possible.
- II.14.4 The party faced with *force majeure* shall not be held to be in breach of its obligations under the Agreement if it has been prevented from fulfilling them by *force majeure*.

ARTICLE II.15 – SUSPENSION OF THE IMPLEMENTATION OF THE ACTION

II.15.1 Suspension of the implementation by the beneficiaries

The coordinator, on behalf of the beneficiaries, may suspend the implementation of the action or any part thereof, if exceptional circumstances make such implementation impossible or excessively difficult, in particular in the event of *force majeure*. The coordinator shall inform the Agency without delay, giving all the necessary reasons and details and the foreseeable date of resumption.

Unless the Agreement or the participation of a beneficiary is terminated in accordance with Article II.16.1, II.16.2 or points (c) or (d) of Article II.16.3.1, the coordinator shall, once the circumstances allow resuming the implementation of the action, inform the Agency immediately and present a request for amendment of the Agreement as provided for in Article II.15.3.

II.15.2 Suspension of the implementation by the Agency

II.15.2.1 The Agency may suspend the implementation of the action or any part thereof:

- (a) if the Agency has evidence that a beneficiary has committed substantial errors, irregularities or fraud in the award procedure or in the implementation of the Agreement or if a beneficiary fails to comply with its obligations under the Agreement;
- (b) if the Agency has evidence that a beneficiary has committed systemic or recurrent errors, irregularities, fraud or breach of obligations under other grants funded by the Union or the European Atomic Energy Community which were awarded to that beneficiary under similar conditions, provided that those errors, irregularities, fraud or breach of obligations have a material impact on this grant; or
- (c) if the Agency suspects substantial errors, irregularities, fraud or breach of obligations committed by a beneficiary in the award procedure or in the implementation of the Agreement and needs to verify whether they have actually occurred.

II.15.2.2 Before suspending the implementation the Agency shall formally notify the coordinator of its intention to suspend, specifying the reasons thereof, and, in the cases referred to in points (a) and (b) of Article II.15.2.1, the necessary conditions for resuming the implementation. The coordinator shall be invited to submit observations on behalf of all beneficiaries within 30 calendar days from receipt of this notification.

If, after examination of the observations submitted by the coordinator, the Agency decides to stop the suspension procedure, it shall formally notify the coordinator thereof.

If no observations have been submitted or if, despite the observations submitted by the coordinator, the Agency decides to pursue the suspension procedure, it may suspend the implementation by formally notifying the coordinator thereof, specifying the reasons for the suspension and, in the cases referred to in points (a) and (b) of Article II.15.2.1, the definitive conditions for resuming the implementation or, in the case referred to in point (c) of Article II.15.2.1, the indicative date of completion of the necessary verification.

The coordinator shall inform the other beneficiaries immediately. The suspension shall take effect five calendar days after the receipt of the notification by the coordinator or on a later date, where the notification so provides.

In order to resume the implementation, the beneficiaries shall endeavour to meet the notified conditions as soon as possible and shall inform the Agency of any progress made in this respect.

Unless the Agreement or the participation of a beneficiary is terminated in accordance with Articles II.16.1, II.16.2 or points (c), (i) or (j) of Article II.16.3.1, the Agency shall, as soon as it considers that the conditions for resuming the implementation have been met or the necessary verification, including on-the-spot checks, has been carried out, formally notify the coordinator thereof and invite the coordinator to present a request for amendment of the Agreement as provided for in Article II.15.3.

II.15.3 Effects of the suspension

If the implementation of the action can be resumed and the Agreement is not terminated, an amendment to the Agreement shall be made in accordance with Article II.12 in order to establish the date on which the action shall be resumed, to extend the duration of the action and to make any other modifications that may be necessary to adapt the action to the new implementing conditions.

The suspension is deemed lifted as from the date of resumption of the action agreed by the parties in accordance with the first subparagraph. Such a date may be before the date on which the amendment enters into force.

Any costs incurred by the beneficiaries, during the period of suspension, for the implementation of the suspended action or the suspended part thereof, shall not be reimbursed or covered by the grant.

The right of the Agency to suspend the implementation is without prejudice to its right to terminate the Agreement or the participation of a beneficiary in accordance with Article II.16.3 and its right to reduce the grant or recover amounts unduly paid in accordance with Articles II.25.4 and II.26.

Neither party shall be entitled to claim compensation on account of a suspension by the other party.

ARTICLE II.16 – TERMINATION OF THE AGREEMENT

II.16.1 Termination of the Agreement by the coordinator

In duly justified cases, the coordinator, on behalf of all beneficiaries, may terminate the Agreement by formally notifying the Agency thereof, stating clearly the reasons and specifying the date on which the termination shall take effect. The notification shall be sent before the termination is due to take effect.

If no reasons are given or if the Agency considers that the reasons exposed cannot justify the termination, it shall formally notify the coordinator, specifying the grounds thereof, and the Agreement shall be deemed to have been terminated improperly, with the consequences set out in the fourth subparagraph of Article II.16.4.

II.16.2 Termination of the participation of one or more beneficiaries by the coordinator

In duly justified cases, the participation of any one or several beneficiaries in the Agreement may be terminated by the coordinator, acting on request of that beneficiary or those beneficiaries, or on behalf of all the other beneficiaries. When notifying such termination to the Agency, the coordinator shall include the reasons for the termination of the participation, the opinion of the beneficiary or beneficiaries the participation of which is terminated, the date on which the termination shall take effect and the proposal of the remaining beneficiaries relating to the reallocation of the tasks of that beneficiary or those beneficiaries or, where relevant, to the nomination of one or more replacements which shall succeed that beneficiary or those beneficiaries in all their rights and obligations under the Agreement. The notification shall be sent before the termination is due to take effect.

If no reasons are given or if the Agency considers that the reasons exposed cannot justify the termination, it shall formally notify the coordinator, specifying the grounds thereof, and the participation shall be deemed to have been terminated improperly, with the consequences set out in the fourth subparagraph of Article II.16.4.

Without prejudice to Article II.12.2, an amendment to the Agreement shall be made, in order to introduce the necessary modifications.

II.16.3 Termination of the Agreement or the participation of one or more beneficiaries by the Agency

II.16.3.1 The Agency may decide to terminate the Agreement or the participation of any one or several beneficiaries participating in the action, in the following circumstances:

- (a) if a change to the beneficiary's legal, financial, technical, organisational or ownership situation is likely to affect the implementation of the Agreement substantially or calls into question the decision to award the grant;
- (b) if, following the termination of the participation of any one or several beneficiaries, the necessary modifications to the Agreement would call into question the decision awarding the grant or would result in unequal treatment of applicants;
- (c) if the beneficiaries do not implement the action as specified in Annex I or if a beneficiary fails to comply with another substantial obligation incumbent on it under the terms of the Agreement;
- (d) in the event of *force majeure*, notified in accordance with Article II.14, or in the event of suspension by the coordinator as a result of exceptional circumstances, notified in accordance with Article II.15, where resuming the implementation is impossible or where the necessary modifications to the Agreement would call into question the decision awarding the grant or would result in unequal treatment of applicants;
- (e) if a beneficiary is declared bankrupt, is being wound up, is having its affairs administered by the courts, has entered into an arrangement with creditors, has suspended business activities, is the subject of any other similar proceedings concerning those matters, or is in an analogous situation arising from a similar procedure provided for in national legislation or regulations;
- (f) if a beneficiary or any related person, as defined in the second subparagraph, have been found guilty of professional misconduct proven by any means;
- (g) if a beneficiary is not in compliance with its obligations relating to the payment of social security contributions or the payment of taxes in accordance with the legal provisions of the country in which it is established or in which the action is implemented;
- (h) if the Agency has evidence that a beneficiary or any related person, as defined in the second subparagraph, have committed fraud, corruption, or are involved in a criminal organisation, money laundering or any other illegal activity detrimental to the Union's financial interests;

TRUE COPY

Principal
Vishwakrishna's (IMEET)

- (ii) if the Agency has evidence that a beneficiary or any related person as defined in the second subparagraph have committed substantial errors, irregularities or fraud in the award procedure or in the implementation of the Agreement, including in the event of submission of false information or failure to submit required information in order to obtain the grant provided for in the Agreement;
- (iii) if the Agency has evidence that a beneficiary has committed systematic recurrent errors, irregularities, fraud or breach of obligations under other grants funded by the Union or the European Atomic Energy Community which would be considered that beneficiary, under similar conditions, provided that those errors, fraud or fraud or breach of obligations have a material impact on this grant.

For the purposes of points (f), (h) and (i), "any related person" shall mean any natural person, which has the power to represent the beneficiary or to take decisions on its behalf.

II.16.3.2 Before terminating the Agreement or the participation of any one or several beneficiaries, the Agency shall formally notify the coordinator and, as may be the case, the beneficiary(ies) concerned of its intention to terminate, specifying the reasons therefor and inviting the coordinator, within 45 calendar days from receipt of the notification, to submit observations on behalf of all beneficiaries and, in the case of point (c) of Article II.16.3.1, to inform the Agency about the measures taken to ensure that the beneficiaries continue to fulfil their obligations under the Agreement.

If, after examination of the observations submitted by the coordinator, the Agency decides to stop the termination procedure, it shall formally notify the coordinator thereof.

If no observations have been submitted or if, despite the observations submitted by the coordinator, the Agency decides to pursue the termination procedure, it may terminate the Agreement or the participation of any one or several beneficiaries by formally notifying the coordinator thereof, specifying the reasons for the termination.

In the cases referred to in points (a), (b), (c), (e) and (g) of Article II.16.3.1, the formal notification shall specify the date on which the termination takes effect. In the cases referred to in points (d), (f), (h), (i) and (j) of Article II.16.3.1, the termination shall take effect on the day following the date on which the formal notification was received by the coordinator.

II.16.4 Effects of termination

Where the Agreement is terminated, payments by the Agency shall be limited to the amount determined in accordance with Article II.25 on the basis of the eligible costs incurred by the beneficiaries and the actual level of implementation of the action on the date when the termination takes effect. Costs relating to current commitments, which are not due for execution until after the termination, shall not be taken into account. The coordinator shall have 60 days from the date when the termination of the Agreement takes effect, as provided for in Articles II.16.1 and II.16.3.2, to produce a request for payment of the balance in accordance with Article II.23.2. If no request for payment of the balance is received within this time limit, the Agency shall not reimburse or cover any costs which are not included in a financial statement approved by it or which are not justified in a technical report approved by it. In accordance with Article II.26, the Agency shall recover any amount already paid, if its use is not substantiated by the technical reports and, where applicable, by the financial statements approved by the Agency.

TRUE COPY

Where the participation of a beneficiary is terminated, the beneficiary concerned shall submit to the coordinator a technical report and, where applicable, a financial statement covering the period from the end of the last reporting period according to Article I.4 for which a report has been submitted to the Agency to the date on which the termination takes effect. The technical report and the financial statement shall be submitted in due time to allow the coordinator to draw up the corresponding payment request. Only those costs incurred by the beneficiary concerned up to the date when termination of its participation takes effect shall be reimbursed or covered by the grant. Costs relating to current commitments, which were not due for execution until after the termination, shall not be taken into account. The request for payment for the beneficiary concerned shall be included in the next payment request submitted by the coordinator in accordance with the schedule laid down in Article I.4.

Where the Agency, in accordance with point (c) of Article II.16.3.1, is terminating the Agreement on the grounds that the coordinator has failed to produce the request for payment and, after a reminder, has still not complied with this obligation within the deadline set out in Article II.23.3, the first subparagraph shall apply, subject to the following:

- (a) there shall be no additional time period from the date when the termination of the Agreement takes effect for the coordinator to produce a request for payment of the balance in accordance with Article II.23.2; and
- (b) the Agency shall not reimburse or cover any costs incurred by the beneficiaries up to the date of termination or up to the end of the period set out in Article I.2.2, whichever is the earlier, which are not included in a financial statement approved by it or which are not justified in a technical report approved by it.

In addition to the first, second and third subparagraphs, where the Agreement or the participation of a beneficiary is terminated improperly by the coordinator within the meaning of Articles II.16.1 and II.16.2, or where the Agreement or the participation of a beneficiary is terminated by the Agency on the grounds set out in points (c), (f), (h), (i) and (j) of Article II.16.3.1, the Agency may also reduce the grant or recover amounts unduly paid in accordance with Articles II.25.4 and II.26, in proportion to the gravity of the failings in question and after allowing the coordinator, and, where relevant, the beneficiaries concerned, to submit their observations.

Neither party shall be entitled to claim compensation on account of a termination by the other party.

ARTICLE II.17 – ADMINISTRATIVE AND FINANCIAL PENALTIES

II.17.1 By virtue of Articles 109 and 131(4) Regulation (EU, EURATOM) No 966/2012 of the European Parliament and of the Council of 25 October 2012 on the financial rules applicable to the general budget of the Union and with due regard to the principle of proportionality, a beneficiary which has committed substantial errors, irregularities or fraud, has made false declarations in supplying required information or has failed to supply such information at the moment of the submission of the application or during the implementation of the grant, or has been found in serious breach of its obligations under the Agreement shall be liable to:

- (a) administrative penalties consisting of exclusion from all contracts and grants financed by the Union budget for a maximum of five years from the date on which the infringement is established and confirmed following a contradictory procedure with the beneficiary; and/or
- (b) financial penalties of 2% to 10% of the value of the contribution the beneficiary concerned is entitled to in accordance with the estimated budget set out in Annex III.

In the event of another infringement within five years following the establishment of the first infringement, the period of exclusion under point (a) may be extended to 10 years and the range of the rate referred to in point (b) may be increased to 4% to 20%.

II.17.2 The Agency shall formally notify the beneficiary concerned of any decision to apply such penalties.

The Agency is entitled to publish such decision under the conditions and within the limits specified in Article 109(3) of Regulation (EU, EURATOM) No 966/2012.

An action may be brought against such decision before the General Court of the European Union, pursuant to Article 263 Treaty on the Functioning of the European Union ("TFEU").

ARTICLE II.18 – APPLICABLE LAW, SETTLEMENT OF DISPUTES AND ENFORCEABLE DECISION

II.18.1 The Agreement is governed by the applicable Union law complemented, where necessary, by the law of Belgium.

II.18.2 Pursuant to Article 272 TFEU, the General Court or, on appeal, the Court of Justice of the European Union, shall have sole jurisdiction to hear any dispute between the Agency and/or the Union and any beneficiary concerning the interpretation, application or validity of this Agreement, if such dispute cannot be settled amicably.

II.18.3 By virtue of Article 299 TFEU, for the purposes of recoveries within the meaning of Article II.26 or financial penalties, the Commission may adopt an enforceable decision to impose pecuniary obligations on persons other than States. An action may be brought against such decision before the General Court of the European Union pursuant to Article 263 TFEU.

TRUE COPY
 Principal
 Vishwarajkumar's (IMEET)

PART B – FINANCIAL PROVISIONS

ARTICLE II.19 – ELIGIBLE COSTS

II.19.1 Conditions for the eligibility of costs

"Eligible costs" of the action are costs actually incurred by the beneficiary which meet the following criteria:

- (a) they are incurred in the period set out in Article I.2.2, with the exception of costs relating to the request for payment of the balance and the corresponding supporting documents referred to in Articles II.23.2 and I.4.1;
- (b) they are indicated in the estimated budget of the action set out in Annex III;
- (c) they are incurred in connection with the action as described in Annex I and are necessary for its implementation;
- (d) they are identifiable and verifiable, in particular being recorded in the accounting records of the beneficiary and determined according to the applicable accounting standards of the country where the beneficiary is established and with the usual cost accounting practices of the beneficiary;
- (e) they comply with the requirements of applicable tax and social legislation; and
- (f) they are reasonable, justified, and comply with the principle of sound financial management, in particular regarding economy and efficiency.

II.19.2 Eligible direct costs

"Direct costs" of the action are those specific costs which are directly linked to the implementation of the action and can therefore be attributed directly to it. They may not include any indirect costs.

To be eligible, direct costs shall comply with the conditions of eligibility set out in Article II.19.1.

In particular, the following categories of costs are eligible direct costs, provided that they satisfy the conditions of eligibility set out in Article II.19.1 as well as the following conditions:

- (a) the costs of personnel working under an employment contract with the beneficiary or an equivalent appointing act and assigned to the action, comprising actual salaries plus social security contributions and other statutory costs included in the remuneration, provided that these costs are in line with the beneficiary's usual policy on remuneration; those costs may also include additional remunerations, including payments on the basis of supplementary contracts regardless of the nature of those contracts, provided that they are paid in a consistent manner whenever the same kind of work or expertise is required, independently from the source of funding used;

The corresponding salary costs of personnel of national administrations are eligible to the extent that they relate to the cost of activities which the relevant public authority would not carry out if the action concerned were not undertaken;

- (b) costs of travel and related subsistence allowances, provided that these costs are in line with the beneficiary's usual practices on travel;

- (g) costs of transfers from the Agency charged by the bank of a beneficiary;
- (h) costs declared by a beneficiary in the framework of another action receiving a grant financed from the Union budget (including grants awarded by a Member State and financed from the Union budget and grants awarded by other bodies than the Agency for the purpose of implementing the Union budget); in particular, indirect costs shall not be eligible under a grant for an action awarded to a beneficiary which already receives an operating grant financed from the Union budget during the period in question;
- (i) contributions in kind from third parties;
- (j) excessive or reckless expenditure;
- (k) deductible VAT.

ARTICLE II.20 – IDENTIFIABILITY AND VERIFIABILITY OF THE AMOUNTS DECLARED

II.20.1 Reimbursement of actual costs

Where, in accordance with Article I.3(a)(i), the grant takes the form of the reimbursement of actual costs, the beneficiary must declare as eligible costs the costs it actually incurred for the action.

If requested to do so in the context of the checks or audits described in Article II.27, the beneficiary must be able to provide adequate supporting documents to prove the costs declared, such as contracts, invoices and accounting records. In addition, the beneficiary's usual accounting and internal control procedures must permit direct reconciliation of the amounts declared with the amounts recorded in its accounting statements as well as with the amounts indicated in the supporting documents.

II.20.2 Reimbursement of pre-determined unit costs or pre-determined unit contribution

Where, in accordance with Article I.3(a)(ii) or (b), the grant takes the form of the reimbursement of unit costs or of a unit contribution, the beneficiary must declare as eligible costs or as requested contribution the amount obtained by multiplying the amount per unit specified in Article I.3(a)(ii) or (b) by the actual number of units used or produced.

If requested to do so in the context of the checks or audits described in Article II.27, the beneficiary must be able to provide adequate supporting documents to prove the number of units declared. However, the beneficiary does not need to identify the actual eligible costs covered or to provide supporting documents, notably accounting statements, to prove the amount declared per unit.

II.20.3 Reimbursement of pre-determined lump sum costs or pre-determined lump sum contribution

Where, in accordance with Article I.3(a)(iii) or (c), the grant takes the form of the reimbursement of lump sum costs or of a lump sum contribution, the beneficiary must declare as eligible costs or as requested contribution the global amount specified in Article I.3(a)(iii) or (c), subject to the proper implementation of the corresponding tasks or part of the action as described in Annex I.

If requested to do so in the context of the checks or audits described in Article II.27, the beneficiary must be able to provide adequate supporting documents to prove the proper implementation. However, the beneficiary does not need to identify the actual eligible costs covered or to provide supporting documents, notably accounting statements, to prove the amount declared as lump sum.

II.20.4 Reimbursement of pre-determined flat-rate costs or pre-determined flat-rate contribution

Where, in accordance with Article I.3(a)(iv) or (d), the grant takes the form of the reimbursement of flat-rate costs or of a flat-rate contribution, the beneficiary must declare as eligible costs or as requested contribution the amount obtained by applying the flat rate specified in Article I.3(a)(iv) or (d).

If requested to do so in the context of the checks or audits described in Article II.27, the beneficiary must be able to provide adequate supporting documents to prove the eligible costs or requested contribution to which the flat rate applies. However, the beneficiary does not need to identify the actual eligible costs covered or to provide supporting documents, notably accounting statements, for the flat rate applied.

II.20.5 Reimbursement of costs declared on the basis of the beneficiary's usual cost accounting practices

Where, in accordance with Article I.3(a)(v), the grant takes the form of the reimbursement of unit costs declared on the basis of the beneficiary's usual cost accounting practices, the beneficiary must declare as eligible costs the amount obtained by multiplying the amount per unit calculated in accordance with its usual cost accounting practices by the actual number of units used or produced. If requested to do so in the context of the checks or audits described in Article II.27, the beneficiary must be able to provide adequate supporting documents to prove the number of units declared.

Where, in accordance with Article I.3(a)(v), the grant takes the form of the reimbursement of lump sum costs declared on the basis of the beneficiary's usual cost accounting practices, the beneficiary must declare as eligible costs the global amount calculated in accordance with its usual cost accounting practices, subject to the proper implementation of the corresponding tasks or part of the action. If requested to do so in the context of the checks or audits described in Article II.27, the beneficiary must be able to provide adequate supporting documents to prove the proper implementation.

Where, in accordance with Article I.3(a)(v), the grant takes the form of the reimbursement of flat-rate costs declared on the basis of the beneficiary's usual cost accounting practices, the beneficiary must declare as eligible costs the amount obtained by applying the flat rate calculated in accordance with its usual cost accounting practices. If requested to do so in the context of the checks or audits described in Article II.27, the beneficiary must be able to provide adequate supporting documents to prove the eligible costs to which the flat rate applies.

In all three cases provided for in the first, second and third subparagraphs, the beneficiary does not need to identify the actual eligible costs covered, but it must ensure that the cost accounting practices used for the purpose of declaring eligible costs are in compliance with the following conditions:

- (a) the cost accounting practices used constitute its usual cost accounting practices and are applied in a consistent manner, based on objective criteria independent from the source of funding;
- (b) the costs declared can be directly reconciled with the amounts recorded in its general accounts; and

- (c) the categories of costs used for the purpose of determining the costs declared are exclusive of any ineligible cost or costs covered by other forms of grant in accordance with Article I.3.

Where the Special Conditions provide for the possibility for the beneficiary to request the Agency to assess the compliance of its usual cost accounting practices, the beneficiary may submit a request for assessment, which, where required by the Special Conditions, shall be accompanied by a certificate on the compliance of the cost accounting practices ("certificate on the compliance of the cost accounting practices").

The certificate on the compliance of the cost accounting practices shall be produced by an approved auditor or, in case of public bodies, by a competent and independent public officer.

The certificate shall certify that the beneficiary's cost accounting practices used for the purpose of declaring eligible costs comply with the conditions laid down in the fourth subparagraph and with the additional conditions which may be laid down in the Special Conditions.

Where the Agency has confirmed that the usual cost accounting practices of the beneficiary are in compliance, costs declared in application of these practices shall not be challenged *ex post*, provided that the practices actually used comply with those approved by the Agency and that the beneficiary did not conceal any information for the purpose of their approval.

ARTICLE II.21 – ELIGIBILITY OF COSTS OF ENTITIES AFFILIATED TO THE BENEFICIARIES

Where the Special Conditions contain a provision on entities affiliated to the beneficiaries, costs incurred by such an entity are eligible, provided that they satisfy the same conditions under Articles II.19 and II.20 as apply to the beneficiary, and that the beneficiary the entity is affiliated to ensures that the conditions applicable to him under Articles II.3, II.4, II.5, II.7, II.9, II.10 and II.27 are also applicable to the entity.

ARTICLE II.22 – BUDGET TRANSFERS

Without prejudice to Article II.10 and provided that the action is implemented as described in Annex I, beneficiaries are allowed to adjust the estimated budget set out in Annex III by transfers between themselves and between the different budget categories, without this adjustment being considered as an amendment of the Agreement within the meaning of Article II.12.

By way of derogation from the first subparagraph, should beneficiaries want to modify the value of the contribution that each of them is entitled to as referred to in point (b) of Article II.17.1 and point (c) of Article II.26.3, the coordinator shall request an amendment in accordance to Article II.12.

The first two subparagraphs do not apply to amounts which, in accordance with Article I.3 (a) (iii) or (c), take the form of lump sums.

ARTICLE II.23 – TECHNICAL AND FINANCIAL REPORTING – REQUESTS FOR PAYMENT AND SUPPORTING DOCUMENTS

II.23.1 Requests for further pre-financing payments and supporting documents

Where, in accordance with Article I.4.1, the pre-financing shall be paid in several instalments and where Article I.4.1 provides for a further pre-financing payment subject to having used all or part of the previous instalment, the coordinator may submit a request for a further pre-financing payment once the percentage of the previous instalment specified in Article I.4.1 has been used.

This certificate shall be produced by an approved auditor or, in case of public bodies, by a competent and independent public official and drawn up in accordance with Annex VII. It shall certify that the costs declared in the interim or final financial statement by the beneficiary concerned or its affiliated entities, on the categories of costs reimbursed in accordance with Article 13(a)(i) are real, accurately recorded and eligible in accordance with the Agreement. In addition, for the payment of the balance, it shall certify that all the receipts referred to in Article 11.25.3.2 have been declared, and

- (v) where required by Article 14.1, an operational verification report ("operational verification report"), produced by an independent third party approved by the Agency and drawn up in accordance with Annex VIII.

This report shall state that the actual implementation of the action as described in the interim or final report complies with the conditions set out in the Agreement.

- (vi) an updated report on the distribution of the Union financial contribution between the beneficiary, including amounts and dates of transfer.

The coordinator shall certify that the information provided in the request for interim payment or for payment of the balance is full, reliable and true. It shall also certify that the costs incurred can be considered eligible in accordance with the Agreement and that the request for payment is substantiated by adequate supporting documents that can be produced in the context of the checks or audits described in Article 11.27. In addition, for the payment of the balance, it shall certify that all the receipts referred to in Article 11.25.3.2 have been declared.

11.23.3 Non-submission of documents

Where the coordinator has failed to submit a request for interim payment or payment of the balance accompanied by the documents referred to above within 60 days following the end of the corresponding reporting period and where the coordinator still fails to submit such a request within 60 days following a written reminder sent by the Agency, the Agency reserves the right to terminate the Agreement in accordance with Article 11.16.3.1(c), with the effects described in the third and the fourth subparagraphs of Article 11.16.4.

11.23.4 Currency for requests for payment and financial statements and conversion into euro

Requests for payment and financial statements shall be drafted in euro.

Beneficiaries with general accounts in a currency other than the euro shall convert costs incurred in another currency into euro at the average of the daily exchange rates published in the C series of *Official Journal of the European Union*, determined over the corresponding reporting period. Where no daily euro exchange rate is published in the *Official Journal of the European Union* for the currency in question, conversion shall be made at the average of the monthly accounting rates established by the Commission and published on its website (http://ec.europa.eu/budget/contracts_grants/info_contracts/infoeuro/infoeuro_en.cfm), determined over the corresponding reporting period.

Beneficiaries with general accounts in euro shall convert costs incurred in another currency into euro according to their usual accounting practices.

ARTICLE 11.24 – PAYMENTS AND PAYMENT ARRANGEMENTS

11.24.1 Pre-financing

The pre-financing is intended to provide the beneficiaries with a float.

TRUE COPY

[Signature]
Principal
Vishwanath (IMEET)

Without prejudice to Articles II.24.5 and II.24.6, where Article I.4.1 provides for a pre-financing payment upon entry into force of the Agreement, the Agency shall pay to the coordinator within 30 days following that date or, where required by Article I.4.1, following receipt of the financial guarantee.

Where payment of pre-financing is conditional on receipt of a financial guarantee, the financial guarantee shall fulfill the following conditions:

- (a) it is provided by a bank or an approved financial institution or, at the request of the coordinator and acceptance by the Agency, by a third party;
- (b) the guarantor stands as first-call guarantor and does not require the Agency and/or the Commission to have recourse against the principal debtor (i.e. the beneficiary concerned); and
- (c) it provides that it remains in force until the pre-financing is cleared against interim payments or payment of the balance by the Agency and, in case the payment of the balance is made in the form of a debit note, three months after the debit note is notified to a beneficiary. The Agency shall release the guarantee within the following month.

II.24.2 Further pre-financing payments

Without prejudice to Articles II.24.5 and II.24.6, on receipt of the documents referred to in Article II.23.1, the Agency shall pay to the coordinator the new pre-financing instalment within 60 days.

Where the statement on the use of the previous pre-financing instalment submitted in accordance with Article II.23.1 shows that less than 70% of the previous pre-financing instalment paid has been used to cover costs of the action, the amount of the new pre-financing to be paid shall be reduced by the difference between the 70% threshold and the amount used.

II.24.3 Interim payments

Interim payments are intended to reimburse or cover the eligible costs incurred for the implementation of the action during the corresponding reporting periods.

Without prejudice to Articles II.24.5 and II.24.6, on receipt of the documents referred to in Article II.23.2, the Agency shall pay to the coordinator the amount due as interim payment within the time limit specified in Article I.4.2.

This amount shall be determined following approval of the request for interim payment and of the accompanying documents and in accordance with the fourth, fifth and sixth subparagraphs. Approval of the request for interim payment and of the accompanying documents shall not imply recognition of the regularity or of the authenticity, completeness and correctness of the declarations and information it contains.

Without prejudice to any ceiling set out in Article I.4.1 and to Articles II.24.5 and II.24.6, the amount due as interim payment shall be determined as follows:

- (a) where, in accordance with Article I.3(a), the grant takes the form of the reimbursement of eligible costs, the amount obtained by application of the reimbursement rate specified in that Article to the eligible costs of the action approved by the Agency for the concerned reporting period and the corresponding categories of costs, beneficiaries and affiliated entities; if Article I.4.1 specifies another reimbursement rate, this other rate shall be applied instead;
- (b) where, in accordance with Article I.3(b), the grant takes the form of a unit contribution, the amount obtained by multiplying the unit contribution specified in that Article by the actual number of units approved by the Agency for the concerned reporting period and for the corresponding beneficiaries and affiliated entities;

- (c) where, in accordance with Article I 3(a), the grant takes the form of a lump sum contribution the amount specified in that Article for the corresponding period to be derived off budget estimates, subject to approval by the Agency of the proper implementation, over the corresponding reporting period of the corresponding tasks or part of the implementation, in accordance with Article I
- (d) where, in accordance with Article I 3(d), the grant takes the form of a flat rate contribution, the amount obtained by applying the flat rate referred to in that Article to the eligible costs or to the contribution accepted by the Agency for the concerned reporting period and the corresponding beneficiaries and affiliated entities.

Where Article I 3 provides for a combination of different forms of grant, these amounts shall be added.

Where Article I 3 requires that the interim payment clears all or part of the pre-financing paid to the beneficiaries, the amount of pre-financing to be cleared shall be deducted from the amount due as interim payment, as determined in accordance with the fourth and fifth subparagraphs.

II.24.4 Payment of the balance

The payment of the balance, which may not be repeated, is intended to reimburse or cover after the end of the period set out in Article I.2.2 the remaining part of the eligible costs incurred by the beneficiaries for its implementation. Where the total amount of earlier payments is greater than the final amount of the grant determined in accordance with Article II 25, the payment of the balance may take the form of a recovery as provided for by Article II 26.

Without prejudice to Articles II.24.5 and II.24.6, on receipt of the documents referred to in Article II.23.2, the Agency shall pay the amount due as the balance within the time limit specified in Article I.4.2.

This amount shall be determined following approval of the request for payment of the balance and of the accompanying documents and in accordance with the fourth subparagraph. Approval of the request for payment of the balance and of the accompanying documents shall not imply recognition of the regularity or of the authenticity, completeness and correctness of the declarations and information it contains.

The amount due as the balance shall be determined by deducting, from the final amount of the grant determined in accordance with Article II.25, the total amount of pre-financing and interim payments already made.

II.24.5 Suspension of the time limit for payment

The Agency may suspend the time limit for payment specified in Articles I.4.2 and II.24.2 at any time by formally notifying the coordinator that its request for payment cannot be met, either because it does not comply with the provisions of the Agreement, or because the appropriate supporting documents have not been produced, or because there is doubt about the eligibility of the costs declared in the financial statement.

The coordinator shall be notified as soon as possible of any such suspension, together with the reasons thereof.

Suspension shall take effect on the date when notification is sent by the Agency. The remaining payment period shall start to run again from the date on which the requested information or revised documents are received or the necessary further verification, including on-the-spot checks, is carried out. Where the suspension exceeds two months, the coordinator may request a decision by the Agency on whether the suspension is to be continued.

TRUE COPY

Vishwanath's (IMEET)

Where the time limit for payment has been suspended following the rejection of one of the technical reports or financial statements provided for by Article 11.23 and the new report or statement submitted is also rejected, the Agency reserves the right to terminate the Agreement in accordance with Article 11.16.3.1(c), with the effects described in Article 11.16.4

II.24.6 Suspension of payments

The Agency may, at any time during the implementation of the Agreement, suspend the pre-financing payments, interim payments or payment of the balance for all beneficiaries, or suspend the pre-financing payments or interim payments for any one or several beneficiaries:

- (a) if the Agency has evidence that a beneficiary has committed substantial errors, irregularities or fraud in the award procedure or in the implementation of the grant, or if a beneficiary fails to comply with its obligations under the Agreement;
- (b) if the Agency has evidence that a beneficiary has committed systemic or recurrent errors, irregularities, fraud or breach of obligations under other grants funded by the Union or by the European Atomic Energy Community which were awarded to that beneficiary under similar conditions, provided that those errors, irregularities, fraud or breach of obligations have a material impact on this grant; or
- (c) if the Agency suspects substantial errors, irregularities, fraud or breach of obligations committed by a beneficiary in the award procedure or in the implementation of the Agreement and needs to verify whether they have actually occurred.

Before suspending payments, the Agency shall formally notify the coordinator of its intention to suspend payments, specifying the reasons thereof and, in the cases referred to in points (a) and (b) of the first subparagraph, the necessary conditions for resuming payments. The coordinator shall be invited to make any observations on behalf of all beneficiaries within 30 calendar days from receipt of this notification.

If, after examination of the observations submitted by the coordinator, the Agency decides to stop the procedure of payment suspension, the Agency shall formally notify the coordinator thereof.

If no observations have been submitted or if, despite the observations submitted by the coordinator, the Agency decides to pursue the procedure of payment suspension, it may suspend payments by formally notifying the coordinator, specifying the reasons for the suspension and, in the cases referred to in points (a) and (b) of the first subparagraph, the definitive conditions for resuming payments or, in the case referred to in point (c) of the first subparagraph, the indicative date of completion of the necessary verification.

The coordinator shall inform the other beneficiaries immediately. The suspension of payments shall take effect on the date when the notification is sent by the Agency.

In order to resume payments, the beneficiaries shall endeavour to meet the notified conditions as soon as possible and shall inform the Agency of any progress made in this respect.

The Agency shall, as soon as it considers that the conditions for resuming payments have been met or the necessary verification, including on-the-spot checks, has been carried out, formally notify the coordinator thereof.

TRUE COPY
Principal
Vishwaniketan's (IMEET)

During the period of suspension of payments and without prejudice to the right to suspend the implementation of the action in accordance with Article II.15.1 or to terminate the Agreement or the participation of a beneficiary in accordance with Article II.16.1 and Article II.16.2, the coordinator is not entitled to submit any requests for payments and supporting documents referred to in Article II.23 or, where the suspension concerns the pre-financing payments or interim payments for one or several beneficiaries only, any requests for payments and supporting documents relating to the participation of the concerned beneficiary or beneficiaries in the action.

The corresponding requests for payments and supporting documents may be submitted as soon as possible after resumption of payments or may be included in the first request for payment due following resumption of payments in accordance with the schedule laid down in Article I.4.1.

II.24.7 Notification of amounts due

The Agency shall formally notify the amounts due, specifying whether it is a further pre-financing payment, an interim payment or the payment of the balance. In the case of payment of the balance, it shall also specify the final amount of the grant determined in accordance with Article II.25.

II.24.8 Interest on late payment

On expiry of the time limits for payment specified in Articles I.4.2, II.24.1 and II.24.2, and without prejudice to Articles II.24.5 and II.24.6, the beneficiaries are entitled to interest on late payment at the rate applied by the European Central Bank for its main refinancing operations in euros ("the reference rate"), plus three and a half points. The reference rate shall be the rate in force on the first day of the month in which the time limit for payment expires, as published in the C series of the *Official Journal of the European Union*.

The first subparagraph shall not apply where all beneficiaries are Member States of the Union, including regional and local government authorities and other public bodies acting in the name and on behalf of the Member State for the purpose of this Agreement.

The suspension of the time limit for payment in accordance with Article II.24.5 or of payment by the Agency in accordance with Article II.24.6 may not be considered as late payment.

Interest on late payment shall cover the period running from the day following the due date for payment, up to and including the date of actual payment as established in Article II.24.10. The interest payable shall not be considered for the purposes of determining the final amount of grant within the meaning of Article II.25.3.

By way of derogation from the first subparagraph, when the calculated interest is lower than or equal to EUR 200, it shall be paid to the coordinator only upon request submitted within two months of receiving late payment.

II.24.9 Currency for payments

Payments by the Agency shall be made in euro.

II.24.10 Date of payment

Payments by the Agency shall be deemed to be effected on the date when they are debited to the Commission's account.

II.24.11 Costs of payment transfers

Costs of the payment transfers shall be borne in the following way:

- (a) costs of transfer charged by the bank of the Agency and/or the Commission shall be borne by the Agency and/or the Commission;

- (b) costs of transfer charged by the bank of a beneficiary shall be borne by the beneficiary;
- (c) all costs of repeated transfers caused by one of the parties shall be borne by the party which caused the repetition of the transfer.

II.24.12 Payments to the coordinator

Payments to the coordinator shall discharge the Agency from its payment obligation

ARTICLE II.25 DETERMINING THE FINAL AMOUNT OF THE GRANT

II.25.1 Calculation of the final amount

Without prejudice to Articles II.25.2, II.25.3 and II.25.4, the final amount of the grant shall be determined as follows,

- (a) where, in accordance with Article I.3(a), the grant takes the form of the reimbursement of eligible costs, the amount obtained by application of the reimbursement rate specified in that Article to the eligible costs of the action approved by the Agency for the corresponding categories of costs, beneficiaries and affiliated entities;
- (b) where, in accordance with Article I.3(b), the grant takes the form of a unit contribution, the amount obtained by multiplying the unit contribution specified that Article by the actual number of units approved by the Agency for the corresponding beneficiaries and affiliated entities,
- (c) where, in accordance with Article I.3(c), the grant takes the form of a lump sum contribution, the lump sum specified in that Article for the corresponding beneficiaries and affiliated entities, subject to approval by the Agency of the proper implementation of the corresponding tasks or part of the action in accordance with Annex I;
- (d) where, in accordance with Article I.3(d), the grant takes the form of a flat-rate contribution, the amount obtained by applying the flat rate referred to in that Article to the eligible costs or to the contribution accepted by the Agency for the corresponding beneficiaries and affiliated entities.

Where Article I.3 provides for a combination of different forms of grant, these amounts shall be added.

II.25.2 Maximum amount

The total amount paid to the beneficiaries by the Agency may in no circumstances exceed the maximum amount specified in Article I.3.

Where the amount determined in accordance with Article II.25.1 exceeds this maximum amount, the final amount of the grant shall be limited to the maximum amount specified in Article I.3.

II.25.3 No-profit rule and taking into account of receipts

II.25.3.1 The grant may not produce a profit for the beneficiaries, unless specified otherwise in the Special Conditions. "Profit" shall mean a surplus of the receipts over the eligible costs of the action.

II.25.3.2 The receipts to be taken into account are the consolidated receipts established, generated or confirmed on the date on which the request for payment of the balance is drawn up by the coordinator, which fall within one of the following two categories:

- (a) income generated by the action; or
- (b) financial contributions specifically assigned by the donors to the financing of the eligible costs of the action reimbursed by the Agency in accordance with Article I.3(a)(i).

- 11.25.3 The following shall not be considered as a profit, to be taken into account for the purpose of verifying whether the grant exceeds a profit for the beneficiaries:
- (a) financial contributions referred to in point (b) of Article 11.25.3.2, which may be used by the beneficiary to cover costs other than the eligible costs under the Agreement;
 - (b) financial contributions referred to in point (b) of Article 11.25.3.2, the main part of which is not due to the donor at the end of the period set out in Article 11.2.2.
- 11.25.4 The eligible costs to be taken into account are the consolidated eligible costs approved by the Agency for the categories of costs reimbursed in accordance with Article 1.3(a).
- 11.25.5 Where the final amount of the grant determined in accordance with Articles 11.25.1 and 11.25.2 would result in a profit for the beneficiaries, the profit shall be deducted in proportion to the final rate of reimbursement of the actual eligible costs of the action approved by the Agency for the categories of costs referred to in Article 1.3(a)(i). This final rate shall be calculated on the basis of the final amount of the grant in the form referred to in Article 1.3(a)(i), as determined in accordance with Articles 11.25.1 and 11.25.2.

11.25.4 Reduction for poor, partial or late implementation

Without prejudice to the right to terminate the Agreement referred to in Article 11.16 and without prejudice to the right of the Agency to apply penalties referred to in Article 11.17, if the action is not implemented or is implemented poorly, partially or late, the Agency may reduce the grant initially provided for, in line with the actual implementation of the action according to the terms laid down in the Agreement.

ARTICLE 11.26 – RECOVERY

11.26.1 Recovery at the time of payment of the balance

Where the payment of the balance takes the form of a recovery, the coordinator shall repay the Agency the amount in question, even if it has not been the final recipient of the amount due.

11.26.2 Recovery after payment of the balance

Where an amount is to be recovered in accordance with Articles 11.27.6, 11.27.7 and 11.27.8, the beneficiary concerned by the audit or OLAF findings shall repay the Agency the amount in question. Where the audit findings do not concern a specific beneficiary, the coordinator shall repay the Agency the amount in question, even if it has not been the final recipient of the amount due.

Each beneficiary shall be responsible for the repayment of any amount unduly paid by the Agency as a contribution towards the costs incurred by its affiliated entities.

11.26.3 Recovery procedure

Before recovery, the Agency shall formally notify the beneficiary concerned of its intention to recover the amount unduly paid, specifying the amount due and the reasons for recovery and inviting the beneficiary to make any observations within a specified period.



If any observations have been submitted or if, despite the observations submitted by the beneficiary, the Agency decides to pursue the recovery procedure, the Agency may confirm recovery by formally notifying to the beneficiary a debit note ("debit note"), specifying the terms and the date for payment.

If payment has not been made by the date specified in the debit note, the Agency shall recover the amount due:

- (a) by offsetting it against any amounts owed to the beneficiary concerned by the Union or the European Atomic Energy Community (Euratom) ("offsetting"), in exceptional circumstances justified by the necessity to safeguard the financial interests of the Union, the Agency may recover by offsetting before the due date, the beneficiary's prior consent shall not be required, an action may be brought against such offsetting before the General Court of the European Union pursuant to Article 263(1) EU;
- (b) by drawing on the financial guarantee where provided for in accordance with Article 14.1 ("drawing on the financial guarantee");
- (c) by holding the beneficiaries jointly and severally liable up to the value of the contribution that the beneficiary held liable is entitled to receive. This contribution shall be that indicated in the estimated budget breakdown as set out in Annex III as last amended;
- (d) by taking legal action in accordance with Article II.18.2 or with the Special Conditions or by adopting an enforceable decision in accordance with Article II.18.3.

For the purposes of point (c) of the third subparagraph, the beneficiaries shall not be jointly and severally liable for financial penalties which could be imposed on any defaulting beneficiary in accordance with Article II.17.

II.26.4 Interest on late payment

If payment has not been made by the date set out in the debit note, the amount due shall bear interest at the rate established in Article II.24.8. Interest on late payment shall cover the period running from the day following the due date for payment, up to and including the date when the Agency and/or the Commission actually receives payment in full of the outstanding amount.

Any partial payment shall first be appropriated against charges and interest on late payment and then against the principal.

II.26.5 Bank charges

Bank charges incurred in connection with the recovery of the sums owed to the Agency and/or the Commission shall be borne by the beneficiary concerned except where Directive 2007/64/EC of the European Parliament and of the Council of 13 November 2007 on payment services in the internal market amending Directives 97/7/EC, 2002/65/EC, 2005/60/EC and 2006/48/EC and repealing Directive 97/5/EC applies.

ARTICLE II.27 – CHECKS, AUDITS AND EVALUATION

II.27.1 Technical and financial checks, audits, interim and final evaluations

The Agency and/or the Commission may carry out technical and financial checks and audits in relation to the use of the grant. It may also check the statutory records of the beneficiaries for the purpose of periodic assessments of lump sum, unit cost or flat-rate amounts.

Information and documents provided in the framework of checks or audits shall be treated on a confidential basis.

In addition, the Agency and/or the Commission may carry out interim or final evaluation of the impact of the action measured against the objective of the Union programme concerned.

Checks, audits or evaluations made by the Agency and/or the Commission may be carried out either directly by its own staff or by any other outside body authorised to do so on its behalf.

Such checks, audits or evaluations may be initiated during the implementation of the Agreement and for a period of five years starting from the date of payment of the balance. This period shall be limited to three years in case the maximum amount specified in Article 1.3 is not more than EUR 60 000.

The check, audit or evaluation procedure shall be deemed to be initiated on the date of receipt of the letter of the Agency or the Commission announcing it.

II.27.2 Duty to keep documents

The beneficiaries shall keep all original documents, especially accounting and tax records, stored on any appropriate medium, including digitalised originals when they are authorised by their respective national law and under the conditions laid down therein, for a period of five years starting from the date of payment of the balance.

This period shall be limited to three years if the maximum amount specified in Article 1.3 is not more than EUR 60 000.

The periods set out in the first and second subparagraphs shall be longer if there are on-going audits, appeals, litigation or pursuit of claims concerning the grant, including in the case referred to in Article 11.27.7. In such cases, the beneficiaries shall keep the documents until such audits, appeals, litigation or pursuit of claims are closed.

II.27.3 Obligation to provide information

Where a check, audit or evaluation is initiated before the payment of the balance, the coordinator shall provide any information, including information in electronic format, requested by the Agency and/or Commission or by any other outside body authorised by it. Where appropriate, the Agency and/or the Commission may request such information to be provided directly by a beneficiary.

Where a check or audit is initiated after payment of the balance, such information shall be provided by the beneficiary concerned.

In case the beneficiary concerned does not comply with the obligations set out in the first and second subparagraphs, the Agency and/or the Commission may consider:

- (a) any cost insufficiently substantiated by information provided by the beneficiary as ineligible;
- (b) any unit, lump sum or flat-rate contribution insufficiently substantiated by information provided by the beneficiary as undue.

II.27.4 On-the-spot visits

During an on-the-spot visit, the beneficiaries shall allow Agency and/or the Commission staff and outside personnel authorised by the Agency and/or by the Commission to have access to the sites and premises where the action is or was carried out, and to all the necessary information, including information in electronic format.

They shall ensure that the information is readily available at the moment of the on-the-spot visit and that information requested is handed over in an appropriate form.

In case the beneficiary concerned refuses to provide access to the sites, premises and information in accordance with the first and second subparagraphs, the Agency and/or the Commission may consider:

- (a) any cost insufficiently substantiated by information provided by the beneficiary as ineligible;
- (b) any unit, lump sum or flat-rate contribution, insufficiently substantiated by information provided by the beneficiary as undue.

II.27.5 Contradictory audit procedure

On the basis of the findings made during the audit, a provisional report ("draft audit report") shall be drawn up. It shall be sent by the Agency and/or the Commission or its authorised representative to the beneficiary concerned, which shall have 30 days from the date of receipt to submit observations. The final report ("final audit report") shall be sent to the beneficiary concerned within 90 days of expiry of the time limit for submission of observations, unless the observations submitted by the beneficiary lead to further audit work, checks or discussions by the Agency and/or the Commission or its authorised representative.

II.27.6 Effects of audit findings

On the basis of the final audit findings, the Agency and/or the Commission may take the measures which it considers necessary, including recovery at the time of payment of the balance or after payment of the balance of all or part of the payments made by it, in accordance with Article II.26.

In the case of final audit findings made after the payment of the balance, the amount to be recovered shall correspond to the difference between the revised final amount of the grant, determined in accordance with Article II.25, and the total amount paid to the beneficiaries under the Agreement for the implementation of the action.

II.27.7 Correction of systemic or recurrent errors, irregularities, fraud or breach of obligations

II.27.7.1 The Agency and/or the Commission may take all measures which it considers necessary, including recovery at the time of payment of the balance or after payment of the balance of all or part of the payments made by it under the Agreement, in accordance with Article II.26, where the following conditions are fulfilled:

- (a) the beneficiary is found, on the basis of an audit of other grants awarded to it under similar conditions, to have committed systemic or recurrent errors, irregularities, fraud or breach of obligations that have a material impact on this grant; and
- (b) the final audit report containing the findings of the systemic or recurrent errors, irregularities, fraud or breach of obligations is received by the beneficiary within the period referred to in Article II.27.1.

II.27.7.2 The Agency and/or the Commission shall determine the amount to be corrected under the Agreement:

- (a) wherever possible and practicable, on the basis of costs unduly declared as eligible under the Agreement.

For that purpose, the beneficiary concerned shall revise the financial statements submitted under the Agreement taking account of the findings and resubmit them to the Agency and/or the Commission within 60 days from the date of receipt of the final audit report containing the findings of the systemic or recurrent errors, irregularities, fraud or breach of obligations.

In the case of systemic or recurrent errors, irregularities, fraud or breach of obligations found after the payment of the balance, the amount to be recovered shall correspond to the difference between the revised final amount of the grant, determined in accordance with Article II.25 on the basis of the revised eligible costs declared by the beneficiary and approved by the Agency and/or by the Commission, and the total amount paid to the beneficiaries under the Agreement for the implementation of the action;

- (b) where it is not possible or practicable to quantify precisely the amount of ineligible costs under the Agreement, by extrapolating the correction rate applied to the eligible costs for the grants for which the systemic or recurrent errors or irregularities have been found

The Agency and/or the Commission shall formally notify the extrapolation method to be applied to the beneficiary concerned, which shall have 60 days from the date of receipt of the notification to submit observations and to propose a duly substantiated alternative method.

If the Agency and/or the Commission accepts the alternative method proposed by the beneficiary, it shall formally notify the beneficiary concerned thereof and determine the revised eligible costs by applying the accepted alternative method

If no observations have been submitted or if the Agency and/or the Commission does not accept the observations or the alternative method proposed by the beneficiary, the Agency and/or the Commission shall formally notify the beneficiary concerned thereof and determine the revised eligible costs by applying the extrapolation method initially notified to the beneficiary.

In the case of systemic or recurrent errors, irregularities, fraud or breach of obligations found after the payment of the balance, the amount to be recovered shall correspond to the difference between the revised final amount of the grant, determined in accordance with Article II.25 on the basis of the revised eligible costs after extrapolation, and the total amount paid to the beneficiaries under the Agreement for the implementation of the action; or

- (c) where ineligible costs cannot serve as a basis for determining the amount to be corrected, by applying a flat rate correction to the maximum amount of the grant specified in Article I.3 or part thereof, having regard to the principle of proportionality.

The Agency and/or the Commission shall formally notify the flat rate to be applied to the beneficiary concerned, which shall have 60 days from the date of receipt of the notification to submit observations and to propose a duly substantiated alternative flat rate.

If the Agency and/or the Commission accepts the alternative flat rate proposed by the beneficiary, it shall formally notify the beneficiary concerned thereof and correct the grant amount by applying the accepted alternative flat rate.

If no observations have been submitted or if the Agency and/or the Commission does not accept the observations or the alternative flat rate proposed by the beneficiary, the Agency and/or the Commission shall formally notify the beneficiary concerned thereof and correct the grant amount by applying the flat rate initially notified to the beneficiary.

TRUE COPY

[Signature]
[Stamp]

In the case of systemic or recurrent errors, irregularities, fraud or breach of obligations found after the payment of the balance, the amount to be recovered shall correspond to the difference between the revised final amount of the grant after flat-rate correction and the total amount paid to the beneficiaries under the Agreement for the implementation of the action.

II.27.8 Checks and inspections by OLAF

The European Anti-Fraud Office (OLAF) shall have the same rights as the Agency and the Commission, notably right of access, for the purpose of checks and investigations.

By virtue of Council Regulation (Euratom, EC) No 2185/96 of 11 November 1996 concerning on-the-spot checks and inspections carried out by the Commission in order to protect the European Communities' financial interests against fraud and other irregularities and Regulation (EU, EURATOM) No 883/2013 of the European Parliament and the Council of 11 September 2013 concerning investigations conducted by the European Anti-Fraud Office (OLAF), OLAF may also carry out on-the-spot checks and inspections in accordance with the procedures laid down by Union law for the protection of the financial interests of the Union against fraud and other irregularities.

Where appropriate, OLAF findings may lead to recovery by the Agency and/or the Commission.

II.27.9 Checks and audits by the European Court of Auditors

The European Court of Auditors shall have the same rights as the Agency and the Commission, notably right of access, for the purpose of checks and audits.

11.02.2016

In the case of systemic or recurrent errors, irregularities, fraud or breach of obligations found after the payment of the balance, the amount to be recovered shall correspond to the difference between the revised final amount of the grant after flat-rate correction and the total amount paid to the beneficiaries under the Agreement for the implementation of the action.

II.27.8 Checks and inspections by OLAF

The European Anti-Fraud Office (OLAF) shall have the same rights as the Agency and the Commission, notably right of access, for the purpose of checks and investigations.

By virtue of Council Regulation (Euratom, EC) No 2185/96 of 11 November 1996 concerning on-the-spot checks and inspections carried out by the Commission in order to protect the European Communities' financial interests against fraud and other irregularities and Regulation (EU, EURATOM) No 883/2013 of the European Parliament and the Council of 11 September 2013 concerning investigations conducted by the European Anti-Fraud Office (OLAF), OLAF may also carry out on-the-spot checks and inspections in accordance with the procedures laid down by Union law for the protection of the financial interests of the Union against fraud and other irregularities.

Where appropriate, OLAF findings may lead to recovery by the Agency and/or the Commission.

II.27.9 Checks and audits by the European Court of Auditors

The European Court of Auditors shall have the same rights as the Agency and the Commission, notably right of access, for the purpose of checks and audits.

TR 2016/01
JP

ANNEX IV

**List of beneficiaries (and affiliated entities
when applicable)**

and

**Mandates provided to the coordinator by the
other beneficiaries**

TRUE COPY
Principal
Michael Jackson's (MMEET)

ANNEX IV - List of Beneficiaries

598914-EPP-1-2018-1-DK-EPPKA2-CBHE-JP

Co-beneficiary institutions	PIG	City	Country
CHIANG MAI UNIVERSITY	998378030	CHIANG MAI	TH
KOLHAPUR INSTITUTE OF TECHNOLOGY	907665764	KOLHAPUR	IN
Mae Fah Luang University	948282671	MUANG DISTRICT	TH
MEHRAN UNIVERSITY OF ENGINEERING & TECHNOLOGY	948276657	JAMSHORO	PK
SIR SYED UNIVERSITY OF ENGINEERING AND TECHNOLOGY, KARACHI, PAKISTAN	915845289	KARACHI	PK
TECHNICAL UNIVERSITY OF SOFIA	999868532	SOFIA	BO
UNIVERSIDAD DE MALAGA	999898311	MALAGA	ES
VISHWANIKETAN	908432549	KHALAPUR, MUM	IN
Co-ordinator	PIG	City	Country
AARHUS UNIVERSITET	999997736	AARHUS C	DK

TRUSTEES
[Signature]
[Date]

MANDATE¹

I, the undersigned,

Associate Professor Rome Chiranukrom, Acting Vice President for International Relations and Alumni Affairs of Chiang Mai University,

representing,

Chiang Mai University (CMU)
Higher Education Institution
239 Huay Kaw Road, Suthep, Muang, Chiang Mai 50200 - Thailand

VAT number: 0994000423179
PIC number 998378030

hereinafter referred to as "the beneficiary",

for the purposes of the signature and the implementation of the grant agreement *Capacity building and Exchange towards attaining Technological Research and modernizing Academic Learning-CENTRAL* (hereinafter referred to as "the grant agreement") with the Education, Audiovisual and Culture Executive Agency (hereinafter referred to as "the Agency")
hereby:

1. Mandate

Aarhus Universitet
Higher Education
(official registration No)
Nordre Ringgade 1, 8000 Aarhus
VAT number: 31119103
PIC number: 999997736

represented by **Brian Bech Nielsen, Rektor, Aarhus Universitet**
(Hereinafter referred to as "the coordinator")

to sign in my name and on my behalf the grant agreement and its possible subsequent amendments with the Agency.

2. Mandate the coordinator to act on behalf of the beneficiary in compliance with the grant agreement.

I hereby confirm that the beneficiary accepts all terms and conditions of the grant agreement and, in particular, all provisions affecting the coordinator and the other beneficiaries. In particular, I acknowledge that, by virtue of this mandate, the coordinator alone is entitled to receive funds from the Agency and distribute the amounts corresponding to the beneficiary's participation in the action.

I hereby accept that the beneficiary will do everything in its power to help the coordinator fulfil his obligations under the grant agreement, and in particular, to provide to the coordinator, on his request, whatever documents or information may be required.

I hereby declare that the beneficiary agrees that the provisions of the grant agreement, including this mandate, shall take precedence over any other agreement between the beneficiary and the coordinator which may have an effect on the implementation of the grant agreement.

This mandate shall be annexed to the grant agreement and shall form an integral part thereof.

SIGNATURE²



Associate Professor Rome Chiranukrom
Acting Vice President for International Relations and Alumni Affairs of Chiang Mai University

[Signature and stamp]

¹ One copy of this Annex shall be included for each beneficiary except for the coordinator.

² If the signatory is not the Rector/President of the Higher Education Institution (or Vice-Rector, Vice-President, Chancellor, Vice-Chancellor), a specific project-related statement signed by the Rector/President must be provided authorising the signatory person to commit the whole institution.

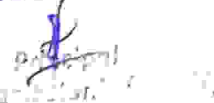
TRUE COPY



Done at [Chiang Mai University], [07 February, 2018]

TRUE COPY

Wichit
[Signature]
(ET)

MANDATE¹

I, the undersigned,

(Mr. Bharat D. Patil),

representing

Kolhapur Institute of Technology, Kolhapur, M7

[official legal status or form: Public Charitable Trust;

[official registration No- Trust no- E 1002]

[R.S.No.199B/1-3, Gokul Shilgaon, Tal - Karveer, Dist - Kolhapur, Kolhapur-416 234, Maharashtra, INDIA.]

VAT number: Not Applicable

PIC number: 9076557b4

hereinafter referred to as "the beneficiary"

for the purposes of the signature and the implementation of the grant agreement **Capacity building and Exchange towards attaining Technological Research and Modernising Academic Learning-CENTRAL** (hereinafter referred to as "the grant agreement") with the Education, Youth and Culture Executive Agency (hereinafter referred to as "the Agency")

herby,

1. Mandate

Aarhus Universitet

Higher education

[official registration No]

Nordre Ringgade 1, 8000 Aarhus

VAT number: 31119103

PIC number: 99999736

represented by **Brian Bech Nielsen, Rektor, Aarhus Universitet**

(Hereinafter referred to as "the coordinator")

to sign in my name and on my behalf the grant agreement and its possible subsequent amendments with the Agency

2. Mandate the coordinator to act on behalf of the beneficiary in compliance with the grant agreement

I hereby confirm that the beneficiary accepts all terms and conditions of the grant agreement and, in particular, the provisions affecting the coordinator and the other beneficiary. In particular, I acknowledge that, by virtue of the mandate, the coordinator alone is entitled to receive funds from the Agency and distribute the amounts corresponding to the beneficiary's participation in the action.

I hereby accept that the beneficiary will do everything in its power to help the coordinator fulfil his obligations under the grant agreement, and in particular, to provide to the coordinator, on his request, whatever documentation or information may be required.

I hereby declare that the beneficiary agrees that the provisions of the grant agreement, including this mandate, shall take precedence over any other agreement between the beneficiary and the coordinator which may have an effect on the implementation of the grant agreement.

This mandate shall be annexed to the grant agreement and shall form an integral part thereof.

SIGNATURE²

(Mr. Bharat D. Patil)

Shri. Bharat D. Patil
Vice Chairman

[Vice-Chairman, **Kolhapur Institute of Technology**, Kolhapur.]

[Signature and stamp]

Done at (Kolhapur), [06/02/2018]

¹ One copy of this Annex shall be included for each beneficiary and one for the coordinator.

² If the signatory is not the Rector/President of the Higher Education Institution (or Vice-Rector, Vice-President, Chancellor, or the Chancellor), a specific project-related statement signed by the Rector/President must be provided, authorising the signatory to act on behalf of the whole institution.

TRUE COPY



MANDATE¹

I, the undersigned,

Associate Professor Vanchai Sirichana, Ph.D,

representing,

Mae Fah Luang University [MFU]
333 Moo 1, Thasud, Muang,
Chaing Rai 57100
THAILAND
VAT number TH0994000209983
PIC number 948782671

hereinafter referred to as "the beneficiary",

for the purposes of the signature and the implementation of the grant agreement *Capacity building and Exchange towards attaining Technological Research and modernizing Academic Learning-CENTRAL* (hereinafter referred to as "the grant agreement") with the Education, Audiovisual and Culture Executive Agency (hereinafter referred to as "the Agency") hereby

1. Mandate

Aarhus Universitet
Higher education
[official registration No]
Nordre Ringgade 1, 8000 Aarhus
VAT number: 31119103
PIC number: 999997736

represented by **Brian Bech Nielsen, Rektor, Aarhus Universitet**
(Hereinafter referred to as "the coordinator")

to sign in my name and on my behalf the grant agreement and its possible subsequent amendments with the Agency.

2. Mandate the coordinator to act on behalf of the beneficiary in compliance with the grant agreement.

I hereby confirm that the beneficiary accepts all terms and conditions of the grant agreement and, in particular, all provisions affecting the coordinator and the other beneficiaries. In particular, I acknowledge that, by virtue of this mandate, the coordinator alone is entitled to receive funds from the Agency and distribute the amounts corresponding to the beneficiary's participation in the action.

I hereby accept that the beneficiary will do everything in its power to help the coordinator fulfil his obligations under the grant agreement, and in particular, to provide to the coordinator, on his request, whatever documents or information may be required.

I hereby declare that the beneficiary agrees that the provisions of the grant agreement, including this mandate, shall take precedence over any other agreement between the beneficiary and the coordinator which may have an effect on the implementation of the grant agreement.

This mandate shall be annexed to the grant agreement and shall form an integral part thereof.

SIGNATURE²

Associate Professor Vanchai Sirichana, Ph.D.

President of Mae Fah Luang University

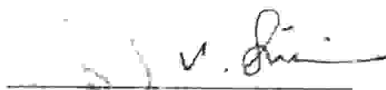

TRUE COPY
[Signature]
[Stamp]

¹ One copy of this Annex shall be included for each beneficiary except for the coordinator.

² If the signatory is not the Rector/President of the Higher Education Institution (or Vice-Rector, Vice-President, Chancellor, Vice-Chancellor), a specific project-related statement signed by the Rector/President must be provided authorising the signatory person to commit the whole institution.

MANDATE¹

I, the undersigned

Muhammad Aslam Uqaili

representing

Vice Chancellor

Mehran University of Engineering & Technology

Jamshoro - Sindh - Pakistan

VAT number: NA

PIC number: 948726051

hereinafter referred to as "the beneficiary",

for the purposes of the signature and the implementation of the grant agreement *Capacity building and Exchange towards attaining Technological Research and modernizing Academic Learning-CENTRAL* (hereinafter referred to as "The grant agreement") with the Education, Audiovisual and Culture Executive Agency (hereinafter referred to as "the Agency") hereby

1. Mandate

Aarhus Universitet

Higher education

[official registration No.]

Nordre Ringgade 1, 8000 Aarhus

VAT number: 3119105

PIC number: 994991776

represented by Brian Bech Nielsen, Rektor, Aarhus Universitet

(Hereinafter referred to as "the coordinator")

to sign in my name and on my behalf the grant agreement and its possible subsequent amendments with the Agency

2. Mandate the coordinator to act on behalf of the beneficiary in compliance with the grant agreement

I hereby confirm that the beneficiary accepts all terms and conditions of the grant agreement and, in particular, all provisions affecting the coordinator and the other beneficiaries. In particular, I acknowledge that, by virtue of this mandate, the coordinator alone is entitled to receive funds from the Agency and distribute the amounts corresponding to the beneficiary's participation in the action.

I hereby accept that the beneficiary will do everything in its power to help the coordinator fulfil his obligations under the grant agreement, and in particular, to provide to the coordinator, on his request, whatever documents or information may be required

I hereby declare that the beneficiary agrees that the provisions of the grant agreement, including this mandate, shall take precedence over any other agreement between the beneficiary and the coordinator which may have an effect on the implementation of the grant agreement

This mandate shall be annexed to the grant agreement and shall form an integral part thereof.

SIGNATURE

Muhammad Aslam Uqaili
Vice-Chancellor

(Signature and stamp)
Mehran University of Engineering & Technology
Jamshoro

TRUE COPY

Principal
Mehran University of Engineering & Technology

¹ One copy of this Annex shall be included for each beneficiary except for the coordinator

² If the signatory is not the Rector/President of the Higher Education Institution (or Vice Rector, Vice President, Chancellor, Vice-Chancellor), a separate project related statement signed by the Rector/President must be provided authorising the signatory person to represent the whole institution

Jamshoro Pakistan 06 Feb, 2018

MANDATE¹

I, the undersigned,

Muhammad Afzal Haque,

representing,

Sir Sved University of Engineering & Technology (SSUET)
Higher Education Institution (Tertiary Level)

Karachi - Sindh - Pakistan
VAT number: NA
PIC number: 915845289

hereinafter referred to as "the beneficiary",

for the purposes of the signature and the implementation of the grant agreement *Capacity building and Exchange towards attaining Technological Research and modernizing Academic Learning-CENTRAL* (hereinafter referred to as "the grant agreement") with the Education, Audiovisual and Culture Executive Agency (hereinafter referred to as "the Agency")
hereby:

1. Mandate

Aarhus Universitet
Higher education
(official registration No)
Nordre Ringgade 1, 8000 Aarhus
VAT number: 31119103
PIC number: 990997736

represented by **Brian Bech Nielsen, Rektor, Aarhus Universitet**
(hereinafter referred to as "the coordinator")

to sign in my name and on my behalf the grant agreement and its possible subsequent amendments with the Agency

2. Mandate the coordinator to act on behalf of the beneficiary in compliance with the grant agreement.

I hereby confirm that the beneficiary accepts all terms and conditions of the grant agreement and, in particular, all provisions affecting the coordinator and the other beneficiaries. In particular, I acknowledge that, by virtue of this mandate, the coordinator alone is entitled to receive funds from the Agency and distribute the amounts corresponding to the beneficiary's participation in the action.

I hereby accept that the beneficiary will do everything in its power to help the coordinator fulfil his obligations under the grant agreement, and in particular, to provide to the coordinator, on his request, whatever documents or information may be required.

I hereby declare that the beneficiary agrees that the provisions of the grant agreement, including this mandate, shall take precedence over any other agreement between the beneficiary and the coordinator which may have an effect on the implementation of the grant agreement.

This mandate shall be annexed to the grant agreement and shall form an integral part thereof.

SIGNATURE²

Muhammad Afzal Haque
Vice Chancellor

[Signature and stamp]

April 19, 2018

Prof. Dr. M. Afzal Haque
Vice-Chancellor
Sir Sved University of Engineering & Technology
Karachi - Sindh - Pakistan

¹ One copy of this Annex shall be included for each beneficiary except for the coordinator.

² If the signatory is not the Rector/President of the Higher Education Institution (or Vice-Rector, Vice-President, Chancellor, Vice-Chancellor), a specific project-related statement signed by the Rector/President must be provided authorising the signatory person to commit the whole Institution

TRUE COPY

Vice-Chancellor (Signature)

MANDATE¹

I, the undersigned,

Georgy Slavchev Mihov, Rector,
representing,

Technical University - Sofia
Higher Education

8 blvd. Kliment Ohridski, 1756 Sofia, Bulgaria

VAT number: BG 831917834

PIC number: 999868532

hereinafter referred to as "the beneficiary",

for the purposes of the signature and the implementation of the grant agreement *Capacity building and Exchange towards attaining Technological Research and modernizing Academic Learning-CENTRAL* (hereinafter referred to as "the grant agreement") with the Education, Audiovisual and Culture Executive Agency (hereinafter referred to as "the Agency")
hereby:

1. Mandate

Aarhus Universitet

Higher education

[official registration No]

Nordre Ringgade 1, 8000 Aarhus

VAT number: 31119103

PIC number: 999997736

represented by **Brian Bech Nielsen, Rektor, Aarhus Universitet**
(Hereinafter referred to as "the coordinator")

to sign in my name and on my behalf the grant agreement and its possible subsequent amendments with the Agency.

2. Mandate the coordinator to act on behalf of the beneficiary in compliance with the grant agreement.

I hereby confirm that the beneficiary accepts all terms and conditions of the grant agreement and, in particular, all provisions affecting the coordinator and the other beneficiaries. In particular, I acknowledge that, by virtue of this mandate, the coordinator alone is entitled to receive funds from the Agency and distribute the amounts corresponding to the beneficiary's participation in the action.

I hereby accept that the beneficiary will do everything in its power to help the coordinator fulfil his obligations under the grant agreement, and in particular, to provide to the coordinator, on his request, whatever documents or information may be required.

I hereby declare that the beneficiary agrees that the provisions of the grant agreement, including this mandate, shall take precedence over any other agreement between the beneficiary and the coordinator which may have an effect on the implementation of the grant agreement.

This mandate shall be annexed to the grant agreement and shall form an integral part thereof.

SIGNATURE²

Prof. DSc. Georgy Slavchev Mihov

Rector, Technical University - Sofia

[Signature and stamp]

Done at Sofia, 06.02.2018



TRUE COPY

Principal
V. Lhvaniketanov (IMEET)

¹ One copy of this Annex shall be included for each beneficiary except for the coordinator.

² If the signatory is not the Rector/President of the Higher Education Institution (or Vice-Rector, Vice-President Chancellor, Vice-Chancellor), a specific project-related statement signed by the Rector/President must be provided authorising the signatory person to commit the whole institution.

MANDATE¹

I, the undersigned,

Prof. Dr. Jose Ángel Narváez-Bueno, President (signed by proxy): Prof. Dr. Susana Gilman, Vice President for International Affairs,

representing,

UNIVERSIDAD DE MÁLAGA (UMA)
Public University
DECRETO 2566/1977
Avda. de Cervantes, 2 E29071 Málaga, Spain
VAT number: Q79180014
RIB number: 999898311

hereinafter referred to as "the grant holder",

for the purposes of the signature and fulfilment of the grant agreement. Capable body by law to benefit towards **attaining Technological Research and Learning Academic Learning CENTRE** (hereinafter referred to as "the grant agreement") with the **Agencia Estatal de Investigación** (hereinafter referred to as "the Agency")

hereby

1. Mandate

Aarhus Universitet
Higher education
[Official registration No.]
Nordre Ringgade 1, 8000 Aarhus
VAT number: 31110103
RIB number: 999991136

represented by Brian Bech Nielsen, Rector, Aarhus Universitet
(hereinafter referred to as "the coordinator")

to sign in my name and on my behalf the grant agreement and all suitable subsequent amendments with the Agency.

2. Mandate the coordinator to act in full of the beneficiary in compliance with the grant agreement.

I hereby confirm that the beneficiary accepts all terms and conditions of the grant agreement, including all provisions affecting the coordination of the beneficiary, on the basis of its knowledge of the content of the mandate, the coordinator alone is entitled to receive funds from the Agency, and to represent the beneficiary concerning to the beneficiary's participation in the activity.

I hereby accept that the beneficiary will be responsible for the provision of the data required to be provided under the grant agreement, and in particular to provide to the coordinator, on the request, all information that may be required.

I hereby declare that the beneficiary accepts that the provisions of the grant agreement, including the coordination, will take precedence over any other agreement between the beneficiary and the coordinator affecting the implementation of the grant agreement.

This mandate shall be annexed to the grant agreement and shall form an integral part thereof.

SIGNATURE²

Prof. Dr. Jose Ángel Narváez-Bueno, President (signed by proxy): Prof. Dr. Susana Gilman, Vice President for International Affairs

Done at Málaga, 06 Oct 2018



TRUE COPY

(MEET)

¹ One copy of this Annex shall be included for each beneficiary except for the coordinator.

² If the signatory is not the Rector/President of the higher education institution (or their Rector or Vice President, Chancellor, or Chancellor), a specific project-related statement signed by the Rector/President must be provided authorising the signatory person to commit the whole institution.

MANDATE¹

I, the undersigned,

[Dr. Sandeep S. Inamdar],

representing

[official] legal status or form- Public Trust]

[official registration No- Trust no- F-9819]

[full official address: Vishwaniketan Campus, Survy no-52, Kumbhlvail, Off.Mumbai-Pune Expressway, near Khalapur Toll naka, Tal-Khalapur, Dist-Rajgad-410202.]

VAT number: GST no- 27AABTV5946P1ZL

PIC number: 908432549

hereinafter referred to as "the beneficiary",

for the purposes of the signature and the implementation of the grant agreement *Capacity building and Exchange towards attaining Technological Research and modernizing Academic Learning-CENTRAL* (hereinafter referred to as "the grant agreement") with the Education, Audiovisual and Culture Executive Agency (hereinafter referred to as "the Agency")

hereby:

1. Mandate

Aarhus Universitet

Higher education

[official registration No]

Nordre Ringgade 1, 8000 Aarhus

VAT number: 31119103

PIC number: 999997736

represented by Brian Bech Nielsen, Rektor, Aarhus Universitet

(Hereinafter referred to as "the coordinator")

to sign in my name and on my behalf the grant agreement and its possible subsequent amendments with the Agency.

2. Mandate the coordinator to act on behalf of the beneficiary in compliance with the grant agreement.

I hereby confirm that the beneficiary accepts all terms and conditions of the grant agreement and, in particular, all provisions affecting the coordinator and the other beneficiaries. In particular, I acknowledge that, by virtue of this mandate, the coordinator alone is entitled to receive funds from the Agency and distribute the amounts corresponding to the beneficiary's participation in the action.

I hereby accept that the beneficiary will do everything in its power to help the coordinator fulfil his obligations under the grant agreement, and in particular, to provide to the coordinator, on his request, whatever documents or information may be required.

I hereby declare that the beneficiary agrees that the provisions of the grant agreement, including this mandate, shall take precedence over any other agreement between the beneficiary and the coordinator which may have an effect on the implementation of the grant agreement.

This mandate shall be annexed to the grant agreement and shall form an integral part thereof.

SIGNATURE²

[Dr. Sandeep S. Inamdar]

[Vice-President, Vishwaniketan]

[Signature and stamp]



¹ One copy of this Annex shall be included for each beneficiary except for the coordinator.

² If the signatory is not the Rector/President of the Higher Education Institution (or Vice-Rector, Vice-President Chancellor, Vice-Chancellor), a specific project-related statement signed by the Rector/President must be provided authorising the signatory person to commit the whole Institution.

TRUE COPY
Principal
Vishwaniketan (Rajgad)

ANNEXES V and VI

Model Technical implementation report(s) and Model Financial statement(s)

The implementation reports, summary reports for publication, financial statements and other documents must be submitted by the beneficiary in the language of the grant agreement in accordance with the templates, the instructions and guidelines for the use of the grant provided on the website of the Executive Agency:

http://cacea.ec.europa.eu/erasmus-plus/beneficiaries-space_en

	Reports and Pre-financing	Deadlines
By way of derogation from Article II.23.1 : Mid-term Report and Pre-financing payment:	<ul style="list-style-type: none"> • Progress report on implementation of the action • Summary report for publication • Statement on the use of the previous pre-financing instalment (Annex VI) 	not later than half way through the eligibility period
	<ul style="list-style-type: none"> • Statement on the use of the previous pre-financing instalment (Annex VI) • Request for payment (Annex VI) 	no specific deadline, but not before the submission of the Progress report on implementation of the action
Final Report:	<ul style="list-style-type: none"> • Final report on implementation of the action • Summary report for publication • Final financial statement and request for payment, including the financial tables for each budget heading • For all grants an (Audit) certificate on the financial statements and underlying accounts (Report of Factual Findings on the Final Financial Report – Type II) 	two months after the end of the eligibility period

Supporting documents (copies, not originals) to be submitted with the Final Report include:

- Invoices related to purchase of equipment where the cost exceeds EUR 25.000
- Invoices and contracts related to subcontractors whether academic or administrative (individuals, companies) if the cost exceeds EUR 25.000
- Any prior authorisation from the Agency

TRUE COPY



Principal
Vishwaniketan (VIMEET)

Agreement 2018 - 3767 / 001 - 001

ANNEX VII

Guidance notes – Report of Factual Findings on the Final Financial Report – Type II

As stated in Article I.4.1 of the Grant Agreement an (Audit) Certificate on the financial statements and underlying accounts (Report of Factual Findings on the Final Financial Report – Type II) must be sent with the Final Report.

You will find as guidance note the template "(Audit) Certificate on the financial statements and underlying accounts" on the website of the Executive Agency:

http://eacea.ec.europa.eu/erasmus-plus/beneficiaries-space_en

TRUE COPY

Principal
Vishwanathan's (IMEET)



Agreement 2018 - 3767 / 001 - 001

ANNEX VIII

Model terms of reference for the operational
verification report: not applicable

TRUE COPY

Municipal
Council's (IMEET)

Agreement 2018 - 3767 / 001 - 001

Ref. MFU 7700/02582



Mae Fah Luang University

Chiang Rai 57100

Thailand

12 June 2019

Dear Ms. RAJPUT SUSMITA SURJITSINH,

Congratulations! We are pleased to inform you that you have been accepted to participate as an exchange student under the UG fellowship programme "Research Exchange topic on Engineered Wood Based on Rice Straw" of the School of Science at Mae Fah Luang University. The programme will be held in the third semester of academic year 2018 from 18 June 2019 to 28 July 2019. Please note that the process of applying to Mae Fah Luang University will be completed once you have a Non-Immigration entry visa code "ED".

The two documents are enclosed herewith.

1. A letter to the Royal Thai Embassy or Consulate General. Please kindly submit this letter when applying for a student visa at the Embassy/Consulate.

2. Acceptance Package. Please kindly complete the Arrival form and submit it to the Global Relations Division at least 1 week before traveling to MFU.

Please do not hesitate to contact our administrative officers of the Global Relations Division, Ms. Wirinpat Phongsuwan at wirinpat.pho@mfu.ac.th or Tel: +66 (0) 5391 6024

Mae Fah Luang University welcome you to be joining us.

Sincerely yours,

A handwritten signature in black ink, reading "Sujitra Wongkasemjit".

Professor Sujitra Wongkasemjit, Ph.D.

Vice President

for President of Mae Fah Luang University

Global Relations Division

Tel: +66 (0) 5391 6024

Fax: +66 (0) 5391 6023

Email: inter@mfu.ac.th

TRUE COPY

Handwritten initials in black ink, possibly "SP".



Ref. MFU 7700/02493

Mae Fah Luang University
Chiang Rai 57100
Thailand

12 June 2019

To Whom It May Concern

This is to certify that Ms. RAJPUT SUSMITA SURJITSINH, Indian, holding passport number T1773389, has been accepted to participate as an exchange student under the UG fellowship programme "Research Exchange topic on Engineered Wood Based on Rice Straw" of the School of Science, Mae Fah Luang University. The programme will be held in the third semester of academic year 2018 from 18 June 2019 until 28 July 2019.

In this regard, it would be appreciated if you could kindly facilitate the formalities regarding the application for a Non-Immigrant entry visa code "ED" to the Kingdom of Thailand for Ms. RAJPUT SUSMITA SURJITSINH.

In advance, we would like to express our sincere appreciation for your favorable consideration.

Sincerely yours,
Sujitra Wongkasemjit

Professor Sujitra Wongkasemjit, Ph.D.
Vice President
for President of Mae Fah Luang University

Global Relations Division
Tel: +66 (0) 5391 6024
Fax: +66 (0) 5391 6023
Email: inter@mflu.ac.th

TRUE COPY

Sujitra Wongkasemjit
Professor
Vice President (INVEST)

มหาวิทยาลัยแม่ฟ้าหลวง
Mae Fah Luang University
Chiang Rai 57100 Thailand

Mae Fah Luang University
999 Mae Fah Luang University Chiang Rai, Thailand 57100
Tel: +66 (0) 5391 6024

Scanned by CamScanner

CERTIFICATE of acceptance

Work done according to contract No. 7-198-19n on 20th May 2019

АКТ

о выполнении работ по договору № 7-198-19н от 20 мая 2019 г.

Contract No. 7-198-19n

№ 7-198-19n

Contract No. 7-198-19n

2019г.

The Client (The Administration, Institute of Management, Entrepreneurship and Engineering Technology) represented by **Dr. S. S. Ismailov**, Secretary on the one side and the Provider (Federal State Autonomous Educational Institution of Higher Education «Ural Federal University named after the 1st President of Russia B.N. Yeltsin» represented by Deputy Vice-Rector for Study **Ekaterina S. Terenteva** on the other side have concluded the present contract as follows: the Provider has completed (delivered) and the Customer has accepted result of work (received services) implemented according to the contract No 7-198-19n on 20th May 2019.

All works performed (services rendered) appropriately, efficiently and meet the requirements and instructions of the Customer. The actual cost of the works (services) is **21,500** (twenty thousand five hundred USD).

This Deliber-Acceptance Certificate is the basis for settlements between the parties.

Сторонами (Исполнителем и Заказчиком) заключен договор на выполнение работ по договору № 7-198-19н от 20 мая 2019 г. Исполнитель (Федеральное государственное автономное образовательное учреждение высшего образования «Уральский федеральный университет имени первого Президента России Б.Н. Ельцина») выполнил (предоставил) и Заказчик принял (получил) результат работы (услуг) согласно условиям договора № 7-198-19н от 20 мая 2019 г. Стоимость выполненных работ (услуг) составляет **21 500** (двадцать тысяч пятьсот) долларов США.

Исполнитель все работы выполнил в соответствии с требованиями Заказчика.

The Provider

Federal State Autonomous Educational Institution of Higher Education «Ural Federal University named after the First President of Russia B.N. Yeltsin»

Address: 620002, Russia, Ekaterinburg, Mira St. 19
Phone: +7(343)375-45-07
Fax: +7(343)375-45-07

Исполнитель

Федеральное государственное автономное образовательное учреждение высшего образования «Уральский федеральный университет имени первого Президента России Б.Н. Ельцина»

Адрес: ул. Мира, 19, г. Екатеринбург, 620002
Телефон: +7(343)375-45-07
Факс: +7(343)375-45-07

Deputy Vice-Rector for the Study
Ekaterina S. Terenteva

Заместитель ректора по учебной работе
Терентева Екатерина Сергеевна

Customer
Vishwakarma Institute of Management
Entrepreneurship and Engineering Technology
Address: H-52, Sector 12, Kharjat, Navi Mumbai
Phone: 9967544386/9987899586
Fax: 9987899586
Dr. S. S. Ismailov Secretary

Заказчик
Исполнитель
Vishwakarma Institute of Management
Entrepreneurship and Engineering Technology
Address: H-52, Sector 12, Kharjat, Navi Mumbai
Phone: 9967544386/9987899586
Fax: 9987899586
Исмаилов Сергей Сергеевич Секретарь

COOPERATION AGREEMENT

for UG fellowship

This Memorandum of Understanding for Cooperation is made by and between

Vishwaniketan

Represented by: Prof. S. S. Inamdar

Survey No. 52, Kumbhivall, Nr. Khalapur Toll Naka,

Off. Mumbai Pune Expressway, Tal. Khalapur, Dist. Raigad, Maharashtra

India

And

Interdepartmental Center CTIF, University of Rome Tor Vergata

(hereafter called CTIF-Italy)

Represented by Prof. Paola Panliccia

Via del politecnico 1,

00133 Rome



PREAMBLE

Whereas Vishwaniketan is a registered trust/society initiated by professionals drawn from industry, education and administration with excellent experience of individuals, has started creating a world class campus near Navi - Mumbai on Pune - Mumbai expressway and whereas Vishwaniketan will create a platform for students, teachers, researchers and professionals to adopt excellent teaching - learning practices inspired by Project Based Learning, encourage entrepreneurship and finally support product development through startups, and will empower teachers, business and the society by using technology solutions evolved and in doing so will promote values, ability of self-learning and taking responsibilities and self-esteem in all stake holders.

Vishwaniketan realizes that there is an acute need to transform professional education in India to create ready to use man power for industry, to inculcate innovative thinking in student community and to empower teaching community. It has strong belief that the education model of University of Rome Tor Vergata has the potential to do this.

CTIF-Italy is an Interdepartmental Center of the University of Rome Tor Vergata, CTIF-Italy is situated at the University of Rome Tor Vergata (Italian: Università degli Studi di Roma Tor Vergata)

TRUE COPY
Principal
Vishwaniketan's (IMEET)

is a university located in Rome, Italy. It is one of the largest research-based institutions in Italy. The University is an international center for research and education and it is well known for scientific studies. In recent years the activity of technology transfer and cooperation with other public and private organizations in different fields has obtained an increasingly important role. The University of Rome Tor Vergata was established in 1981 with the goal of providing high quality education for students preparing to meet the ever-evolving needs and opportunities of the 21st century workforce.

CTIF-Italy has as objective research and educational activities in the field of development of interdisciplinary applications of *Information and Communication Technology* (ICT). The activity subject of this agreement is expected to increase the interest of these students to join University of Rome Tor Vergata MS Programme in a later stage.

CTIF-Italy and Vishwaniketan agree to the following:

Article 1: CTIF-Italy, will offer 45 days training programmes on the content / courses / projects to be developed jointly for the undergraduate students of CTIF- Vishwaniketan Network in India.

Article 2: Indian undergraduate students in engineering, who have completed 2/3 years of their studies will be the participants/candidates of the UG Fellowship programme. The students who have completed at least three good projects in our PBL method, will be selected by Vishwaniketan for this fellowship/ project internship of 6 weeks (in the period 15th May to 30th July every year, tentatively).

Article 3: The supervisor/professor shall give guidance to students through personal meetings, tutorials, classroom teaching if necessary and daily supervision by a junior staff member. The PBL approach involves guidance only if the student is not able to solve the problem. Review presentations fortnightly may be arranged for smooth/meaningful completion of the higher end project. At the end, a certification will be done by CTIF-Italy.

Article 4: Areas of interest for the Indian students are mechanical, electrical, energy, civil, electronics communication, wireless, robotics, automation, 5G, computer/software engineering but not limited to such areas.

Article 5: Any expenses of the visiting student related to the visiting period, such as Daily expenses, accommodation fee, personal medical coverage and insurance for civil liability against third parties need to be covered by the visiting student. No money contribution will be reimbursed by Tor Vergata University to the Visiting student.

Article 6: The present agreement will remain valid for 1 year. It may be renewed for the same period upon request of one of the parties;

Vice-Coordinator of the Interdepartmental Center CTIF

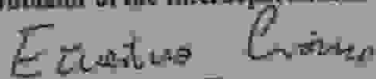
Dr. Ernestina Cianca

13-05-2019

Vishwaniketan

Prof. S. S. Inamdar



Vice-President
Vishwaniketan

TRUE COPY

Vishwaniketan (MEEET)



11/01/2019 11:11

MEMORANDUM OF UNDERSTANDING (MOU)
BETWEEN

VISHWANIKETAN, INDIA

AND

POZNAN UNIVERSITY OF TECHNOLOGY (PUT), POLAND

With the objective of promoting cooperation in academic, educational and research, between

Poznan University of Technology (PUT) located in Poznan under following address: 5 Pr. Mier
Skiłodowskiej-Curie, 60-065 Poznań, tel. +48 61 666 3037, e-mail: put@put.poznan.pl

represented by Rector of Poznan University of Technology, Prof. Dr
hab. inż. Tomasz Łodygowski, and VISHWANIKETAN located in Hyderabad following address: 5-7-1

No. 52, DIF, Mambalapur, Laxmipeta, Kamalapur, Tel. No. 0846 210000, e-mail: secretary@vishwaniketan.org.in

represented by Vice President, Dr. Sundeep Inamdar the following agreement is established:

Article 1

1. The scope of the cooperation between PUT and VISHWANIKETAN may include any field or subject of academic education and research upon which the parties agree.
2. The cooperation may be conducted via various activities, among them:
 - collaborative research, lectures, symposia, workshops and conferences;
 - exchange of scholars and researchers;
 - exchange of graduate and doctoral students;
 - exchange of undergraduate students;
 - exchange of scientific publications in fields which are of interest to both parties to MOU to update information.



Article 2

Implementation of the exchange or other kinds of cooperation based on hereby agreement shall take place on the level of primary organizational units of the PUT. The number of members of said who are to participate in a visit or exchange program, their pay and conditions of service shall be regulated in each case, and based on a separate executive agreement signed by the head of a PUT organizational unit, and by the head of an organizational unit of the VISHWANIKETAN, giving due consideration to the capabilities and needs of the individuals and the institutions concerned.

TRUE COPY

Sundeep Inamdar (VISEP)

Article 3

The various schools part of the institution to take the department to the best extent possible equipped with an individual insurance policy covering medical and dental treatment as well as hospital policy for out-of-hospital incidents.

Article 4

A separate plan is to be prepared by both parties for each point as well. The plan agreed upon by cooperating parties shall be the basis for joint academic centres. The cost of which shall be borne by both parties.

Article 5

Both universities shall seek financing of joint activities from external sources available to them.

Article 6

All agreements relating to present and future intellectual rights owned by any party as well as the prospective ones that are to arise while performing this agreement, shall be ruled by a separate agreement.

Article 7

All changes to hereby agreement require written form to their validity, under the pain of nullity.

Article 8

The hereby agreement becomes effective upon the date of last signature and will be valid for a period of five years with the possibility of its prior termination.

Article 9

This agreement is written in English, in two originals, all of them of equal validity.

Poznan University of Technology

Vishwaniketan



Prof. Tomasz Lodygowshi

[Signature]

Recto: **Prof. Tomasz Lodygowshi**

Vice President

**Dr. Sandeep Inamdar
Vice-President
Vishwaniketan**

[Signature]

MEMORANDUM OF UNDERSTANDING FOR COOPERATION

This Memorandum of Understanding for Cooperation is made by and between

International Institute for Innovations in ICT (I³I)

Higher educational

Represented by Dr. Ashok Chandra, I³I

Subhas Institute Campus, Survey No. 52, Karatbivli, Kholapur

India

And

Global Information Resource Forum for India (GISFI)

Represented by Prof. Ranjan Prasad, Chairman, GISFI

And

Vishwaniketan

Represented by Dr. S. B. Inamdar, Secretary

Survey No. 52, Karatbivli, Nr. Kholapur Toll Naka,

OIE Mumbai Free Export Zone, Tal. Kholapur, Dist. Palghat, Maharashtra

India

And

Research and Education Laboratory in Information Technologies (AIT)

Represented by Spyridoula (Didou) Prevedourou, Managing Director

2, Adriaensiou and Papala str., 11525 Athens, Greece

2011/11

TRUE COPY

[Signature]
Principal
Vishwaniketan's (VIMEET)

PROXABLE

Whereas International Institutes for Innovation in ICT (I4CT) will be established for the purpose of advancing the research, development and the technical reputation of India by the joint effort and work with its European university partners to lead the next revolution in engineering and technology by the unanimous focus given on the education, research and the workplace.

Whereas I4CT will combine the best of the Indian, European and International top level skills in education, research and entrepreneurship and will endeavor to provide its partners an opportunity to enter into huge market of India for mutual benefits.

Whereas Global ICT Standardization Forum for India, (GISFI), has been registered under society registration and Public Trust act in India and is an Indian standardization body active in the area of Information and Communication Technologies (ICT) and related application areas, such as energy, telemedicine, wireless robotics, biotechnology and whereas GISFI addresses the research and product development of ICT in India and provides a bridge towards the globalization of the Indian achievements; the issue of Technology, Governance and Development, and a platform for rising awareness of the importance and the internationalization of the higher education in the field are supported by the government of India.

Whereas Vishwaniketan is a registered trust/society initiated by professionals drawn from industry, education and administration with excellent experience of individuals, has started creating a world class campus near Navi - Mumbai on Pune - Mumbai expressway and whereas Vishwaniketan will create a platform for students, teachers, researchers and professionals to adopt excellent teaching - learning practices inspired by Project Based Learning, encourage entrepreneurs and finally support product development through startups, and will empower teachers, business and the society by using technology solutions evolved and in doing so will promote values, ability of self-learning and taking responsibilities and self-esteem in all stake holders and therefore has hosted CTIF India and GISFI and is willing to create I4CT in its campus.

Whereas Research and Education Laboratory in Information Technologies (AIT), a non-profit Scientific Association has as its scope the development and promotion of Research, Science, Technology, Education and Training in the fields of Informatics, Telecommunication and Innovation Management, aiming for the strengthening of the Scientific, Technological, Research and Entrepreneurial Potential and Work Force of Greece, and the wider promotion of Research, Science and Education in the above mentioned fields;

Now, therefore, the Parties have agreed to enter into cooperation as described in this MoU for Cooperation (hereinafter referred to as the 'Cooperation') - as follows:

The purpose of the Cooperation

The purpose of the Cooperation is to enable IICT to become a strong and flourishing high-tech research and development center and an academic institute with global excellence providing space for Indian, European and other international institutions to collaborate. Internationally acclaimed infrastructure will be created. Faculty from all over world will be involved to create excellent learning experience to the student community worldwide. The purpose is also for AIT to strengthen its international relations, especially in India, and to become a preferred European partner for Vishwaniketan, IICT and its partners, in fields of common strategic importance and interest.

Research will be focused for direct usefulness to consumer and user industry in India, Greece and global market. The global partners will receive an opportunity to understand, enter and work with the respective markets of India and Greece for mutual benefits.

IICT will conduct M. S. and Ph. D. education and research programs in cooperation with AIT and other international partner universities and industry in accordance with the legislation in Greece/India.

The goal of IICT is to:

1. Create academic model of excellence (with Problem Based Learning (PBL) methodology) for UG/PG courses in engineering with enrollment of 600 UG students and 150 PG students in various discipline of engineering, and 120 PG students in Management every year.
2. Offer help/assistance/guidance/consultancy and other services to global user industry in the area of engineering and technology and PBL methodology to academic institutes in South Asia.
3. Initiate patent based research in engineering & technology and other faculties of education in India.
4. Create systems platform for Indian academic institutes and industry for commercialization of research outcome of the scholars working in IICT.
5. Encourage establishment of Joint Ventures of Industry partners from India and Europe for business Development in India for global Market.

1. The Parties

14CT

14CT i.e. International Institute for Innovations in ICT is to be established as an independent Research and Development center within Vishwaniketan campus in close association with GISFI under the laws of India. It will have initially seven research groups, namely: Basic Telecommunications, Bioinformatics, Biotechnology, Telehealth/Telemedicine, Chemoinformatics, Nanoinformatics and Technology Evolution & Applications. Basic Telecommunication will consist of four research sub-groups, namely, Network and Security, Navigation and Communication (NavCom), Radio Access Technology, and Cognitive and Software Defined Radio, Artificial Intelligence and Computer Engineering, Information Technology, and Physical Science. The Research areas and fields of interest will be broadened from time to time as per need of the user industry.

It is expected that the first areas to be added will be in the fields of Energy, Mechanical Engineering and Electrical Engineering.

14CT distinguishes itself from other Research and Development (R&D) initiatives by the expected impact of joint Indian-European development of world leading technology solutions with the primary objective of advancing education by using the PBL model, commercialization of IPR out of research and techno entrepreneurship promotion at the level of Masters and innovation at PhD level.

With 14CT's application of PBL, the education system in India which is mainly targeted toward achieving a job will move to the domain of innovative research leading to commercialization.

Innovative research projects are expected to lead to Intellectual Property Rights (IPRs). 14CT aims that the commercialization of the technology will give birth to the number of startup companies based on future technology leading towards the long term shift of R&D in India. 14CT will have a holding company of its own which will provide self-sufficiency to the institute. All the startup companies will have shares in the institute's holding company; in turn the holding company will provide funding to the institute to carry out further basic research in thrust area of 14CT.

14CT will work in the larger interest of complete world and specifically for improvement in Academic and Corporate life of India as a whole. 14CT may be supported by the government of India, the government of Denmark, Aalborg University, European Commission and any other Industry/institution who wish to contribute to the objectives of 14CT.

GISFI

GISFI will create a platform to facilitate discussion between bodies like major industrial countries or regions of the world and proactively interact in international forums such as, ITU, IEEE, ETSI, etc. GISFI will be a platform for discussions on standardization of

standard products and services intended primarily for the Indian market which would also be implementable globally. The forum has the following scope:

1. Unifying standardization efforts in India
2. Creating standards addressing the specificity of the Indian market
3. Creating an information center on Indian activities in ICT and in other areas
3. Promoting Indian initiatives to develop into global standards
4. Create institutions-facilities for technical and power development in India for usefulness to global society

VISHWANIKETAN

Vishwaniketan realizes that there is an acute need to transform professional education in India to create ready to use man power for industry, to inculcate innovative thinking in student community and to empower teaching community. It has strong belief that collaboration with AIT will play a catalytic role in achieving its objectives. It is developing 21 acres campus very close to an international airport in Navi Mumbai, where fastest development in India is happening. Vishwaniketan believes in fully transparent, ethical, and professional administration which will finally gather all the expertise from industry and academic institutions to see the transformation in Indian education in very close future. Merit based selection of students, very vibrant teaching learning processes and industry friendly faculty will be the silent points of Vishwaniketan.

AIT:

An internationally-renowned nonprofit education and research center in the fields of information technology, telecommunications, and innovation management, was founded in 2002 by the INTRACOM group of companies. In its 14 years of existence, AIT has become a beacon of research and education excellence in the field of ICT in Greece and beyond, achieving an impressive number of important milestones that clearly form an outstanding record for any institution of its size and youth. This is manifested by:

- International recognition and distinctions in the Academic and Research arenas: AIT's research outputs, as well as its individual faculty members have attracted a high number of international distinctions that testify to the achieved level of excellence and know-how of its people.
- Research grant attraction: In less than a decade of active involvement in external research fund raising, AIT ranks 7th in Greece in the EU ICT funding arena. This achievement is clearly attributed to the research prowess of AIT.
- Strong network of R&D partners in Europe and worldwide. Trusted and valuable partnerships and collaborations have been established with more than 300 organisations.
- Industrial research excellence: AIT runs regularly a number of industry-commissioned research projects, on target topics that give a clear competitive advantage to the corresponding companies, these also result in a number of patents for the generated intellectual property.
- Startup companies: AIT is a key player in Greece's emerging startup ecosystem. This activity complements AIT's know-how in the field of business innovation and entrepreneurship, which has helped tens of AIT's graduates put together their own

companies. All in lead partner in a European effort towards the establishment of a Virtual Open Innovation Ecosystem.

3. Organization

I4CT will be established as an independent Research and Development center under Public Private Partnership (PPP) Model. I4CT will work on the objectives initially as follows:-

1. To register at least 100 PhD students in the identified areas in engineering technology and other areas and conduct research useful/suitable to user industry.
2. To create "center for PBL excellence" for Asia to improving the teaching learning practices in academic institutes by introducing PBL methodology.
3. To register at least 50% patents out of the work done by the PhD students under the guidance of the eminent researchers all over the world.
4. Offer help/assistance/guidance/consultancy and other services to user industry in engineering technology and all other areas.

Regarding I4CT, the stake holders and partners (i.e. GISFI, Vishwaniketan, Aalborg University, AIT and other industry partners) will be involved in line with the principal of 'proportionate ownership on the investment they are doing' for fulfillment of these objectives.

Following organization structure will be adopted for fulfillment of the goals and the objectives already defined:

1. GISFI, the partners involved with CTIF India and Vishwaniketan will develop and control the vision, activities and functioning style and all other operative matters for I4CT.
2. The ownership of the I4CT will be with the governing body of 11 members ensuring appropriate involvement of all stake holders and partners, which will be created in the due course of time.
3. The governing body will consist of eleven members to be decided from time to time, depending upon the involvement and investment made by the stake holders and institutes/industry.
4. An organizational structure will be evolved as per existing styles in a world class academic/research institute for the fulfillment of the vision of I4CT.

The establishment and running of I4CT will be absolute responsibility of the governing body of I4CT.

4. Facilities.

Vishwaniketan will make available 10 acres (42000 mtr. Sq.) of land for I4CT. On this land, I4CT will build a research facility in the domain as decided by the governing body.

A. Organization

IACT will be established as an Independent Research and Development center under Public-Private Partnership (PPP) Model. IACT will work on the objectives outlined as follows:

1. To register at least 100 PhD students in the identified areas in engineering technology and other areas and conduct research work/submitable to user industry.
2. To create "center for PBL excellence" for Asia to improve the teaching learning practices in academic institutes by introducing PBL methodology.
3. To register at least 50% patents out of the work done by the PhD students under the guidance of the eminent researchers all over the world.
4. Offer help/assistance/guidance/consultancy and other services to user industry in engineering technology and all other areas.

Regarding IACT, the stake holders and partners (i.e. GISPI, Vishwaniketan, Ashborg University, AIT and other industry partners) will be involved in line with the principal of 'proportional ownership on the investment they are doing' for fulfillment of these objectives.

Following organization structure will be adopted for fulfillment of the goals and the objectives already defined:

1. GISPI, the partners involved with CTF India and Vishwaniketan will develop and control the vision, activities and functioning style and all other operative matters for IACT.
2. The ownership of the IACT will be with the governing body of 11 members ensuring appropriate involvement of all stake holders and partners, which will be created in the due course of time.
3. The governing body will consist of eleven members to be decided from time to time, depending upon the involvement and investment made by the stake holders and institutes/industry.
4. An organizational structure will be evolved as per existing styles in a world class academic/research institute for the fulfillment of the vision of IACT.

The establishment and running of IACT will be absolute responsibility of the governing body of IACT.

4. Facilities.

Vishwaniketan will make available 10 acres (±2000 mt. Sq.) of land for IACT. On this land, IACT will build a research facility in the domain as decided by the governing body.

The time duration for setting up the I4CT is set to be 5 years and failure to this will automatically return the registered research hotel back to Vishwaniketan.

During the first phase of I4CT, managed by project group at Vishwaniketan will provide research facilities of about 10,000 square feet to serve the need of research facilities, the duration of which shall not exceed three years after the opening of I4CT.

I4CT Education and research activities will shift into the building constructed in phase I. I4CT Management, Vishwaniketan and GISFI shall, as stated below, be solely and fully responsible for managing and maintaining the research facility, hereunder for the maintenance of the building, offices and laboratories and shall cover any and all running cost for the facility.

5. Responsibilities of I4CT

In addition to the responsibilities mentioned under Articles 3 & 4 above, I4CT shall be responsible for the following:

I4CT will conduct Masters and PhD programs in collaboration with AIT, GISFI and other universities/industrial parties in accordance with the law and regulations applicable.

I4CT will introduce and conduct a 'UG fellowship' programme for 300 UG students with universities and research centers abroad, for 45 days training on projects, PBL, specific courses on recent advancements or special learning on topics of common interests.

I4CT will conduct undergraduate programs in cooperation with Vishwaniketan and AAI, AIT providing always that the relevant and necessary approvals and permissions are granted under national legislation, of the countries involved.

Up to 100 PhD/post graduate candidates will be registered per year under the supervision of competent professors and practitioners from Europe and India.

Finally I4CT will provide its expertise to all stake holders for exploring possibilities of their expansion in the huge market of India in education, consultancy within the legal boundary of Indian Judiciary System.

6. Responsibilities of GISFI/CTIF India

In addition to the responsibilities mentioned under Articles 3 & 4 above, GISFI shall be responsible for the following:

GISFI will develop and control the vision, activities and functioning style and all other operative matters for I4CT Jointly with other stake holders and partners.

GISFI and the partners involved with CTIF India will be responsible also to create the laboratories, other academic infrastructure by way of raising funds through investments.

Further, under the framework of the CTIF-GISFI, AIT will be responsible to conduct at least one or more lectures/workshops in the Indian universities to train such laboratory scientists, postgraduate and Ph.D. students of the universities. AIT will also fund the program, infrastructure.

The efforts of GISFI and CTIF India will be instrumental in helping more than 1000 students all over the world to IACT for training, teaching, workshop, and research. In the help of its partners, hereunder the CTIF Global Network across the globe.

7. Responsibilities of Vishwaniketan

In addition to the responsibilities mentioned under Articles 3 & 4 above, Vishwaniketan will be responsible in providing all the local support, logistic support as a host of IACT.

Vishwaniketan will, if necessary, provide assistance in arrangement of hostel facility to all post graduate, PhD students of IACT for a period of three years.

The charges/fees for the hostel facility will be according to the usual practice of Vishwaniketan for other students staying in the campus. The staff quarter will also be made available to employees, faculty, PhD students, postgraduate and undergraduate students of the IACT on rent decided as per the prevailing norms, depending upon availability. All the centralized facilities such as guest house, recreation, canteen/mess, banking etc. will be made available to IACT in sharing basis on mutually decided charges in line with existing norms.

In addition, Vishwaniketan may offer teaching assignments to the faculty and PhD students of IACT on remuneration (Work Scholarship) based on existing practices of Vishwaniketan. The eligible faculty of Vishwaniketan may be involved in teaching, research activities of IACT on remunerative basis based on prevailing norms.

Furthermore, Vishwaniketan will establish center for PBL studies to improve the academic quality of interested Engineering Colleges in the CTIF-GISFI- Vishwaniketan Network amongst around 3500 Engineering colleges in India. The PBL center of excellence may offer its service to institutions all over south Asia. Vishwaniketan will invite AIT to cooperate in this initiative on mutually agreed terms and conditions.

8. Responsibilities of AIT

Whenever AIT enters into cooperation with partners in India regarding the education of PhD, MS and undergraduate students, the general principles for this cooperation will be added as Appendix to this MoU. This general principle will be replaced by a more detailed agreement to be entered into by AIT and Vishwaniketan.

AIT shall provide information regarding existing PhD programs and sufficient information regarding requirements, terms and conditions for enrolling PhD students in the relevant programs as well as information regarding the course of the PhD study etc.

A proactive initiative is expected from AIT for administering programs like the PhD-program which is one of the main subjects of this cooperation as well as other efforts which are launched with reference to this MoU. AIT is also expected to engage in faculty exchange, administrative/study tours of Vishwaniketan faculty and students etc., to be agreed by the involved Parties.

To ensure the success of the Ph.D.-program and of the individual students, the Parties agree that Vishwaniketan will assess potential students and make recommendations regarding eligible students to AIT. AIT will consider accepting eligible students upon Vishwaniketan's recommendation supplemented by interviews and written assignments performed by supervisors and staff representing the relevant Doctoral School.

The Ph.D.-studies shall be completed in accordance with an Appendix of this MoU.

AIT will, in cooperation with Vishwaniketan, make efforts to achieve external funding for joint activities, such as bilateral research projects, network activities, establishment of laboratories at IACT, scholarships, training courses, faculty exchange etc. as its proportionate investment in IACT.

AIT wishes to offer UG/MS and PhD integrated programs. As per the signing of this MoU, it is unclear what the possibilities will be under both Greek and Indian legislation.

AIT will consider offering 45 days training programs on the content / courses / projects to be developed jointly for the undergraduate students of IACT Network in India. AIT is also expected to proactively involve into sharing of lectures, conferences conducted at AIT through video conferencing. AIT will provide faculty for short time trainings of faculty and students of IACT, at AIT offices and will also give full access to the laboratories and library for the students and faculty of IACT. Further details, such as methodology, fee structure, etc. will be agreed by the involved Parties and shall be included in a separate annex to this Cooperation Agreement.

A Principle of 85% Tuition waiver will be considered for all such fellowships, a proactive approval will be taken by AIT to increase interest of Indian Students in all such fellowships.

9. Financial issues

There is no money to be paid between the Parties under this MoU.

10. Compliance

The I-ICTSI and SA forward state its subject to ensure that the MoU is in compliance with relevant and mandatory laws of India. All shall not in any way be held responsible or liable for any kind of act performed by IICL and or ICSI which violates the law and rules and regulations of Government of India and all competent authorities concerned.

Furthermore I4CT shall ensure that any activity which is launched and performed under this Cooperation Agreement is in compliance with relevant and mandatory laws and regulation applicable for the parties concerned.

11. Duration

This MoU shall enter into force by June^{1st} 2016 and shall be in force for 3 years. The Parties may agree to prolong the duration of this MoU. Such Agreement shall be made in writing.

12. Termination

This MoU expires automatically per May 31st 2019 unless an addendum has been made, cf. Article 12 above and unless it has been terminated cf. this Article.

Each Party is entitled to terminate this MoU in the next of substantial breach by another party of its obligations under this MoU. Termination should be made in writing with a two months' notice in advance.

In the event that this MoU is terminated with reference to any of the two paragraphs above, the parties involve shall make their best efforts to ensure that such termination shall not have significant consequences for all running activities, provided always that General Principles or other agreements to be entered into by the Parties are respected.

TRUE COPY

MEMORANDUM OF UNDERSTANDING

Between Teesside University of Middlesbrough TS1 3BA and Vishwaniketan, Survey No-52 Off Mumbai-Pune Expressway Kumbhivari Tal. Khalapur Maharashtra 410203 (the Parties)

Dated this Memorandum is to take effect:

1. This Memorandum of Understanding ("MOU") recognises the intention of the Parties to establish and build a relationship, co-operate in a broad range of areas and to work together to gain a mutual benefit. The Parties may seek to encourage and develop collaborative activities in various ways, including but not limited to: the exchange of scholarly ideas/expertise and research; the support of specific discipline interaction; the development of programmes, student exchanges, and advance entry from one institution to the other where the students are appropriately qualified.
2. Separate agreements will be required for any definitive collaborations as articulated by the Teesside University's quality processes. The Parties understand that any financial considerations associated with any collaboration will be dealt with via a legally binding contract. In the course of discussions, the Parties may, before the entering of a legally binding contract, wish to document the understanding reached on financials. In such cases, the Parties agree to append any such understanding to this MOU in Appendix A.
3. Both Parties recognise the value of this MOU in promoting its own programme and activities. However, any marketing material/activity which includes reference to the other party must be sent to that Party and be approved before use.
4. This MOU is for 3 years in the first instance and will be reviewed thereafter. Each Party has the right to discontinue the arrangements subject to a period of 3 months' notice to be given. This MoU may also be terminated at any time by mutual consent of both Parties.
5. In the event of termination, the Parties will honour any agreed commitments either via existing agreed arrangements or by suitable negotiated alternatives.
6. This MOU signifies a statement of intention to collaborate but is not a legally binding document and has no legal effect. The Parties agree that neither Party will make and claim against the other for any loss or damage including but not limited to any consequential damages or lost profits, arising from any discussions, actions taken in reliance on this MOU or for termination of the negotiations without reaching a comprehensive agreement.

Signatures to the Agreement



13/2/18
Dr David Bell
Pro Vice Chancellor International



14/2/18
Dr S-S Inamdar
Vice President

For and on behalf of Teesside University

For and on behalf of Vishwaniketan

TRUE COPY

Memorandum of Understanding Between

_____ and _____
_____ and _____
_____ and _____

MEMORANDUM

1. This Memorandum of Understanding between _____ and _____ is intended to establish certain exchange programs between _____ and _____ in order to promote the development of joint teaching activities, and other educational programs of mutual interest.

TERMS

In recognition of the relationship to be established and the valuable considerations, the parties agree as follows:

1.1. Program of the Exchange Agreement (Article 1)

1.2. The primary objective of this Agreement is to create a basis for cooperative efforts between _____ and _____ to permit the academic interchange of students and faculty, and research information between the two institutions.

1.3. The parties agree that this Agreement is incorporated into, and will provide the foundation and framework for, the particular projects developed by academic and administrative units from the two institutions and memorialized in other implementing Project Agreements.

1.4. "Host Institution" is a party to this Agreement that sends its faculty and/or students to the other party (institution) for the purposes of teaching, study and/or research.

1.5. "Guest Institution" is a party to this Agreement that accepts the visiting faculty and/or students from the other party for teaching, study and/or research.

2.0. Term, Renewal and Termination

2.1. This Agreement shall take effect on the 1st day of February, 2018 and shall terminate on the 1st day of September, 2019.

2.2. This Agreement may be automatically renewed for 3 additional year periods by written agreement of both parties.

THIS COPY

[Signature]
DIRECTOR

4.1.1. The faculty member at the Home Institution shall be responsible for providing the student with the appropriate supervision and instruction. The student shall be held responsible for the completion of the program and shall be held responsible for the payment of tuition and fees at the Host Institution. The student shall be held responsible for the payment of travel expenses to and from the Host Institution. The student shall be held responsible for the payment of any other expenses incurred by the student while attending the Host Institution.

4.1.2. The student shall be held responsible for the payment of any other expenses incurred by the student while attending the Host Institution.

4.2. Approval of Program

4.2.1. The student shall be held responsible for the payment of any other expenses incurred by the student while attending the Host Institution.

4.2.2. The student shall be held responsible for the payment of any other expenses incurred by the student while attending the Host Institution.

4.3. Student Cooperation

4.3.1. A student of one institution proposing to undertake short-term non-degree program study under a specific faculty member at the other institution must do the following:

4.3.1.1. Draft and submit a detailed study program for approval by the Home Institution.

4.3.1.2. If approved by the Home Institution, the student through the Home Institution submit it to the Host Institution, to obtain formal approval of the program in writing from the supervising college and the faculty member at the Host Institution.

4.3.1.3. If the Host Institution officials grant their approval, it will render maximum cooperation to facilitate the proposal.

4.3.2. The tuition, fees, and costs applicable to the student's attendance at the Host Institution shall be the responsibility of the student who shall send payment for such directly to the Host Institution.

4.3.3. Host Institution will charge Home Institution students Host Institution "in-State" tuition and fees, and will help locate housing and provide other assistance to the visiting student.

5.0. Joint Research Projects

5.1. In the event a joint research project is proposed by either party, such research effort shall be carefully scrutinized by both parties to evaluate the need for the joint effort, the qualifications of the proposed participating faculty members, and the location of the research activity. If a decision is made by both parties hereto to approve the proposed project as a possible joint effort, both institutions agree to actively seek outside funding for the proposed joint research project prior to their final approval and implementation of the joint project.

5.2. In such joint projects between the two institutions, care shall be taken to assure that

TRUE COPY

Victoria Jackson's (MSSET)

8.7. Publications and Research Findings

Both parties agree that publications resulting from the collaboration between the two parties shall be the joint intellectual property of both parties. The signatories of this Agreement must give recognition to this Agreement in all publications and research findings. The Agreement must also be mentioned in all courses and formal presentations of the results of the collaboration under the term "Jointly".

Both parties agree to the exchange of publications, such as books, articles, reports, and other official publications and research findings, which are created by either of the parties in connection with this Agreement.

Should any faculty collaborator result in an invention or intellectual property, the parties shall immediately meet through an agreed representative and seek an equitable and fair understanding as to ownership and other possible interests that may arise. Any such discussions shall at all times strive to preserve a harmonious and collaborative relationship between the parties.

8.8. Legal All research and other activities conducted under this Agreement must be conducted in accordance with the laws, rules, and regulations applicable to each institution. In the case of Institutions, these are the laws, rules, and regulations of the State of _____, Arkansas and the United States. In the case of Exchange Campus, these are the laws, rules, and regulations of India.

8.9. Academic and Disciplinary Rules

The parties agree that the academic requirements of both educational institutions shall be respected and that all current, applicable policies covering matters of academic responsibility and social discipline will be distributed to the other party and carefully followed.

8.10. Budgetary Considerations

Resources for implementation of this Agreement may come from either party depending upon budgetary availability. Neither party is obligated to expend any resources in connection with this Agreement. No implementation of any portion of this Agreement or counter-agreement for specific projects may be initiated prior to the written assurance of such budgetary availability to the other party herein. To the extent any external funding is required by Institution in order to implement this Agreement and funding for such purposes is not appropriated to Institution or is not otherwise available to Institution, Institution shall have no further financial obligations upon such

TRUE COPY

Signature of _____
(Name of the Party)

1. The Board of Directors of the University of Mysore shall have the authority to make any such amendments to the Statutes of the University of Mysore as may be necessary for the better management of the University of Mysore.

- 1. The Board of Directors of the University of Mysore shall have the authority to make any such amendments to the Statutes of the University of Mysore as may be necessary for the better management of the University of Mysore.
- 2. The Board of Directors of the University of Mysore shall have the authority to make any such amendments to the Statutes of the University of Mysore as may be necessary for the better management of the University of Mysore.

In testimony whereof,
I, the Secretary, do hereby certify that the above-mentioned Statutes of the University of Mysore have been duly adopted and are now in force.

It is hereby certified that the above-mentioned Statutes of the University of Mysore have been duly adopted and are now in force.

IN WITNESS WHEREOF, the undersigned representatives of both parties have executed this instrument of the Appointment this 14th day of September 1971.

IN SIGNATURE:

Board of Directors of the University of
Mysore acting for and on behalf of the
University of Mysore at Mysore.

by _____

(Signature)
Sri M. M. Chinnappa
(Printed Name)
The Chancellor for Mysore and Administrative
(Title)

U. S. CHINNAPPA, AMBBS,

Managing Director of
Vishwaniketan at Mysore, India

by

(Signature)
Dr. S. Indraprakash
(Printed Name)
Managing Trustee of Vishwaniketan
(Title)

Signature
Managing Trustee of Vishwaniketan
Mysore, Karnataka



TRUE COPY

MEMORANDUM OF UNDERSTANDING

This Memorandum of Understanding (this "MOU") is entered into by and between Vishwaniketan (hereafter "Vishwaniketan") and the Board of Regents of the Nevada System of Higher Education, on behalf of the University of Nevada, Las Vegas (hereafter "UNLV"). The institutions desire to engage in discussions regarding academic, scientific and cultural collaboration under this non-binding agreement. This MOU is effective as of the last date any authorized signatory affixes his/her signature below ("Effective Date").

I. OBJECTIVES

Under this MOU the institutions intend to promote cooperation which will advance educational and research activities as well as opportunities for faculty, staff and students to contribute to enhancing the functions of universities in both countries.

II. ACTIONS

- A. Actions that may be carried out under this MOU include:
1. Discussions pertaining to potential joint research activities;
 2. Discussions regarding personnel exchange for purposes of study and research;
 3. Discussions regarding information exchange in fields of interest to academic personnel and students of Vishwaniketan and UNLV; and
 4. Discussions regarding academic personnel exchange for lectures, talks, symposiums, conversations and sharing of experiences.
5. Further areas for cooperation may be agreed from time to time.
- B. The institutions agree that the programs that may develop from this cooperation will be subject to the following:
1. Each program developed under this MOU shall be memorialized by a separate written implementing agreement.
 2. Any opportunities for students and exchange of academic personnel will be in conformance with the rules, regulations and policies established by each institution.
 3. The parties will each appoint one responsible person for the discussion of the programs developed under this MOU.
 4. For each program that may be developed under this MOU, the parties will agree upon the

- country. The participation of each institution in any of the specific programs will be subject to the availability of funds.
- Both institutions agree that the personnel provided by each institution for the implementation of the programs that may arise from this MOU will be affiliated exclusively with his/her employer, that each institution will assume its responsibilities to this end, and in no case will either institution in any way be liable for the actions of the other.
 - All intellectual property owned or controlled by either institution will remain its sole and exclusive property and will not be used by the other institution for any purpose without the prior written authorization of the institution that owns or controls it. Nothing contained in this MOU shall be deemed to grant to the other institution any right or license in respect of any patents, inventions, technical information or any intellectual property rights owned by either institution.
 - This MOU is subject to the provisions of the State of Nevada Public Records Law, Nev. Rev. Stat. 239.010, such that this MOU and any information or documents received from Vishwamitikan may be open to public inspection and copying.
 - Vishwamitikan certifies that it is not suspended, debarred or ineligible from entering into contracts with the Executive Branch of the Federal Government of the United States, or in receipt of a notice of proposed debarment from any United States agency or local public body. Vishwamitikan agrees to provide immediate notice to UNLV in the event of being suspended, debarred or declared ineligible by any state or federal department or agency, or upon receipt of a notice of proposed debarment during the term of this MOU.
 - No publicity or advertising regarding any activities or developments under this MOU will be released by either institution except by mutual written agreement of the institutions. Neither institution may use any identifying marks or logos of the other without the express written permission of the other institution.
 - The English version of this MOU shall be authoritative version of the MOU for all purposes. In the event of a conflict between the English version and any translation of this MOU, the English version shall control.
 - Nothing herein shall be construed to create an agency relationship between the institutions, or any employment relationships between the institutions for any faculty or staff member. The institutions are independent contractors and no legal relationship is intended by this MOU.

III. DURATION, MODIFICATIONS AND TERMINATION

This MOU will be in effect for three (3) years from the Effective Date. This MOU may be modified or extended by written amendment executed by both institutions. This MOU may be terminated for any reason by either institution by giving to the other thirty (30) days written notice prior to such termination.

IV. DISPUTE RESOLUTION

This MOU is entered into by the institutions in good faith. The institutions will use their best efforts to resolve any conflict or dispute which may arise regarding the interpretation and enforcement of this MOU. Any disputes or conflicts which cannot be resolved at the appropriate operating levels shall be referred to the presidents of each institution for final resolution.

V. ASSIGNMENT

Neither this MOU, any internal herein nor any claim hereunder, shall be assigned or transferred by either institution unless expressly authorized in writing by the other institution.

VI. COMMUNICATION AND COORDINATION

To provide for consistent and effective communication between Vishwaniketan and UNLV, the following points of contact are established:

For UNLV:

Susan Thompson
Office of International Programs
4505 S. Maryland Parkway
Box 456012
Las Vegas, Nevada 89154-6012
USA
Susan.thompson@unlv.edu
702 895-3896

For Vishwaniketan:

Dr. Janhavi Jaanwar, Director, Vishwaniketan
Survey number 52, Kumbhivalli, Rajgadh, Maharashtra-410202
093987899586
director@vishwaniketan.edu.in

[Signature Page to Follow]

TRUE COPY

Dr. Janhavi Jaanwar
Vishwaniketan
Director

IN WITNESS WHEREOF, the parties have executed this MOU as of the Effective Date.

VISHWANIKETAN

Approved by:

Dr. Sandeep S Isamdar
Vice President, Vishwaniketan



Date: _____

BOARD OF REGENTS OF THE NEVADA SYSTEM OF HIGHER EDUCATION ON
BEHALF OF THE UNIVERSITY OF NEVADA, LAS VEGAS

Recommended by:

Susan Thompson
Director, International Programs

Date: _____

Recommended by:

Ryan Venka
Dean, Howard R. Hughes College of Engineering

Date: 7/13/20

Approved by:

Javier A. Rodriguez

Indicate page to sign &
designate page

55/100

Christopher Heavry
Senior Vice Provost
Signed by Javier A. Rodriguez
on behalf of Chris L. Heavry

Date: _____

TRUE COPY
of Original
Witnessed by _____
(PRINTED)

MEMORANDUM
Of
UNDERSTANDING
Between
VISHWANIKETAN'S
iMEET, KUMBHIVALI
And
MECHATOL ENGINEERING
SOLUTIONS, PUNE
(Training Agency)

TRUE COPY
[Signature]
Vishwaniketan's (iMEET)

1 Executive Summary:

**Memorandum of Understanding
Between
MECHATOL ENGINEERING SOLUTIONS, PUNE
(Training Agency)
Vishwaniketan's i MEET, Kumbhivali(ViMEET)**

1.1 Context:

This MOU is hereby entered into by Vishwaniketan's i MEET Kumbhivali, Tal. Khalapur between MECHATOL ENGINEERING SOLUTIONS, PUNE here in after referred to as the training agency & the Vishwaniketan's iMEET, Kumbhivali hereinafter referred to as ViMEET collectively all signatories of this MoU will be known as cooperators.

1.2 Purpose

The Purpose of this MoU is to formalize a relationship between the a for mentioned institute & training agency for the purpose of cooperating in providing training & educational information & to facilitate the development of students towards industry readiness.

1.3 Objective

The objective of this MoU is to deliver On-Job training on DESIGN OF MECHANICAL SYSTEMS. The students of ViMEET who have enrolled for the said program will be work on industrial live problems. These training programs for ViMEET, covers the curriculum finalized between the two organizations, copies of which with signatures of both parties are enclosed to this agreement.

1.4 Training Agency & ViMEET agree to:

1. ViMEET shall provide the infrastructure for delivering the classroom sessions & lab sessions.
2. Training agency shall provide competent trainers for theory & lab sessions, few specific equipment's/software will also be provided by the training agency.
3. ViMEET shall provide the stay and food arrangement of the Trainer in the institute's Hostel, at the cost as per prevailing norms of the Institute. The installation of the software will be done by the Training agency one day prior to the training schedule.

It is mutually agreed and understood by all Parties that:

The Training agency shall follow the course content and Timetable will be provided by ViMEET. Refer Appendix I & II for pre-requisites and project respectively.

TRUE COPY
[Signature]
Rishi Vaid
Vishwaniketan's (iMEET)

2 2.1 **Contact Details:**

College:

Dr. B. R. Patil
Principal
Vishwaniketan's iMEET
Kumbhivali.

Training Agency:

Mr. Anand Bhise,
MECHATOL ENGINEERING
SOLUTIONS, Kothrud, PUNE (411036)

3 3.1 **1.1.1 Commencement/Expiration/Termination:**

This MoU takes effect upon the signature of the training agency & VIMEET and shall remain in effect for the particular course from date of execution which will be valid for 01 Year (One Year). This MOU may be extended or amended upon written request of the training agency & subsequent with concurrence of the other party. Any of the parties may terminate this MOU with 30 days written notice to the other party.

3.3 **Methodology:**

Feedback: The training agency may take feedback of the participants as & when they feel necessary. VIMEET will take feedback from students on regular basis & will inform the trainers about the outcome of the feedback. The suggestions evolved out of this feedback will be MANDATORY on the part of trainers.

3.4 **Project:**

After completion of the training the training agency must provide a good quality project for each student in the group of (3-4) students and it evaluated by the Industry Experts. It is the sole responsibility of the training agency that 95% students must complete the project.

After completion of training, the training agency shall provide the support for solving the problems for completion of project by skype meeting/ Email exchange/ telephonic discussion/college visit.

The trainer must review the project (by physical presence at Vishwaniketan's iMEET, Khalapur Campus) at least twice in the semester (The dates will be finalized mutually agreed on)

3.5 **Examination and Certificate:**

Project Exhibition for evaluation of projects will be conducted after completion of the course delivery & project. Certificates will be provided by training agency & VIMEET to all participants. The evaluation scheme will be as follows:

- 20% Marks course learning
- 30% Marks Assignment and Attendance
- 50% Marks -Project

TRUE COPY
[Signature]
[Stamp]





5.6 Certificates and Awards:

Successful candidates will receive a "Course Completion Certificate" signed by ViMEET & training agency. The Certificates will be issued by training Agency.

4. 4.1 Payment Disbursement:

1. 50% of the total amount shall be paid to training agency after 2 week from the date of successful completion of the basic training of said On-job training Program.
2. 25% after the second Visit of trainer to review the project progress of students.
3. 25% after successful completion of VAP exhibition in the EVEN semester.
4. In case of unsatisfactory conduction of Projects, the payment done by ViMEET will be given back proportionately in consultation.

Signature:

Principal, ViMEET, Khalapur Name: Dr. B. R. Patil  Date: 23/05/2019	Authorized signatory of Training Agency Name: Mr. Anand Blaise  Date: 23/05/2019
Witnesses 1. Name: Mr. Bhaveshkumar Pasi Sign: 	2. Name: Mr. S.A. Dhotare Sign: 

TRUE COPY

Vishwanathar, ViMEET

Appendix I

Pre-requisite :

Students should know basic knowledge of Solidworks software.
Topics as follows.

Software Name	Topic
Solidworks	1. Introduction of Solidworks modelling
	2. Tool used in solidworks modelling
	3. Introduction to solidworks assembly
	4. Tool used in solidworks assembly
	5. Hands on practicals
	6. Tools to solidworks sheet metal
	7. Introduction to solidworks sheetmetal
	8. Hands on practicals on solidworks sheetmetal
	9. Introduction to solidworks structure
	10. Tools in solidworks structure
	11. Hands on practicals on solidworks structure
	12. Introduction to solidworks drawing
	13. Hands on practicals of solidworks drawing

Dr. S. S. Srinivasan
Head of Department
Mechanical Engineering

Appendix II

Projects

S.No.	Title
1	Special purpose machine
2	Jigs and fixtures
3	Automotives
4	Injection Moulding
5	Material Handling System

TRUE COPY
21
Vishwanathar's (IMEST)

про надання освітніх послуг аспірантам, докторантам – іноземним громадянам (on providing educational services for postgraduate students, doctoral students - foreign citizens)

м. Київ Київ

від 24 10 2019 року

НАЦІОНАЛЬНИЙ ТЕХНІЧНИЙ УНІВЕРСИТЕТ УКРАЇНИ - КИЇВСЬКИЙ ПОЛІТЕХНІЧНИЙ ІНСТИТУТ ІМЕНІ ІГОРЯ СІКОРСЬКОГО державна форма власності підприємства Міністерство освіти і науки України

NATIONAL TECHNICAL UNIVERSITY OF UKRAINE "IGOR SIKORSKY KYIV POLYTECHNIC INSTITUTE"

public form of ownership, subordination: to the Ministry of Education and Science of Ukraine

в особі Першого проректора Якименка Юрія Івановича, який діє на підставі Доручення ректора №76 від 24.09.2019, далі - виконавець, із КОШВАНИН Івані МАНЕ КІШОР ВІШВАНАТХ

In the person of the First vice-rector Yuriy Yakymenko, acting on the basis of Rector's Power of Attorney №76 from 24.09.2019 (hereinafter - the performer), as the first Party, and

MANE KISHOR VISHWANATH (country, surname, name)

(hereinafter - the recipient), as the second Party, together - the parties, and each separately, the party, have concluded this agreement on providing educational services for postgraduate students, doctoral students - foreign citizens (hereinafter referred to as the agreement) on the following.

ПРЕДМЕТ ДОГОВОРУ

1 Предметом договору є надання освітньої послуги Виконавець бере на себе зобов'язання за рахунок коштів замовника здійснити надання замовнику освітньої послуги, а саме:

SUBJECT OF THE AGREEMENT

1. The subject of the agreement is the provision of educational services. The performer undertakes at the expense of the recipient to provide an educational service, namely:

Table with 2 columns: освітня послуга, форма навчання, строк надання освітньої послуги, ступінь вищої освіти, назва спеціальності/освітньої програми/спеціалізації, обсяг освітньої складової здобувача вищої освіти в кредитах Європейської кредитної трансферно-накопичувальної системи

Table with 2 columns: Educational service, Form of training, Duration of service provision, Level of higher education, Name of specialty/educational program/specialization, the volume of the higher education in ECTS Credits

- 1.1 Місцем виконання договору (надання освітньої послуги) є проспект Перемоги, 37, м. Київ. 1.2 Замовник вступає до КПІ ім. Ігоря Сікорського згідно законодавства України та нормативної бази КПІ ім. Ігоря Сікорського

- 1.1. The place of the agreement execution (provision of the service) is 37, Peremohy Avenue, Kyiv, Ukraine. 1.2. The recipient enters the Igor Sikorsky KPI according to the legislation of Ukraine and the normative base of the Igor Sikorsky KPI

ОБОВ'ЯЗКИ ТА ПРАВА ВИКОНАВЦЯ

- 2. Виконавець зобов'язаний: 2.1 надати замовнику освітню послугу на рівні стандартів вищої освіти (якщо законодавством передбачені державні стандарти надання освітньої послуги); 2.2 забезпечити дотримання прав замовника; 2.3 інформувати замовника про правила та вимоги щодо організації надання освітньої послуги, її якості та змісту, про права й обов'язки сторін під час надання та отримання освітньої послуги; 2.4 видати замовнику документ про вищу освіту (науковий ступінь) державного зразка (якщо відомою до законодавства за освітньої програмою передбачено видачу такого документу) за умови виконання замовником навчального навантаження в обсязі, необхідному для здобуття певного ступеня вищої освіти. 3. Виконавець має право: 3.1 вимагати від замовника своєчасно вносити плату за освітню послугу в розмірах та порядку, встановлених договором; 3.2 відкликати замовника за невиконання або неповного виконання його законодавства України та умов договору, а тому чинні в разі несвочасного внесення плати за освітню послугу

OBLIGATIONS AND THE RIGHTS OF THE PERFORMER

- 2. The performer shall: 2.1 provide the recipient with an education service at the level of higher education standards (if the law provides for state standards for the provision of educational services); 2.2 ensure compliance with recipient rights; 2.3 inform the recipient about the rules and requirements regarding the organization of the provision of educational services, their quality and content, his rights and obligations when receiving the educational service; 2.4 issue a document on the higher education (scientific degree) of the state standard (if in accordance with the legislation, the educational program provides for the issuance of such document), provided that the recipient completes the curriculum in the amount necessary for obtaining a certain degree of higher education. 3. The performer has the right: 3.1 to demand from the recipient timely payment for the educational service in the amount and in the order established by the agreement; 3.2 send down the recipient for failure or improper fulfillment of the requirements of the legislation of Ukraine and the terms of the agreement, including the missing the terms of payment of the fees for the educational service by the customer.

ОБОВ'ЯЗКИ ТА ПРАВА ЗАМОВНИКА

- 4. Замовник зобов'язаний: 4.1 своєчасно вносити плату за освітню послугу в розмірах та порядку, встановлених договором; 4.2 дотримуватися обов'язків, передбачених статтею 61 Закону України "Про вищу освіту", виконувати (якщо вказано законодавством України, Статуту КПІ ім. Ігоря Сікорського, Правил внутрішнього розпорядку КПІ ім. Ігоря Сікорського, Кодексу етики КПІ ім. Ігоря Сікорського та інших нормативних актів КПІ ім. Ігоря Сікорського); 4.3 пострафікувати документи, подані про освіту, тільки при вступі (документ про освіту або рівень отриманої замовником освіти) до

DUTIES AND THE RIGHTS OF THE RECIPIENT

- The recipient is obliged to: 4.1 pay in time for educational service in the amount and in the manner prescribed by the agreement; 4.2 comply with the duties stipulated in Article 63 of the Law of Ukraine "On Higher Education", with other requirements of the legislation of Ukraine, the Charter of the Igor Sikorsky KPI, Regulations on the organization of the educational process at the Igor Sikorsky KPI, Rules of the Internal Regulations of the Igor Sikorsky KPI, Code of honor of the Igor Sikorsky KPI and other normative acts of the Igor Sikorsky KPI; 4.3 notify the education documents submitted at the entrance (the education document or on the level of education received by the recipient) before the

допомогу другий семестру першого року навчання.
 4.4. Як свій рахунок залишає територію України і виїжджає до країни постійного проживання протягом місяця по завершенні навчання

- 5. Замовник має право вимагати від виконавця:
 - 5.1. надання освітньої послуги на рівні стандартів вищої освіти (якщо законодавством передбачено державні стандарти вищої освіти);
 - 5.2. забезпечення дотримання прав замовника;
 - 5.3. надати замовнику документи про вищу освіту (навчальний ступінь) державного зразка (якщо передбачено до законодавства за освітньою програмою передбачено вилучити такого документа) та умови виконання замовником державного навчального в обсязі, необхідному для здобуття певного ступеня вищої освіти;
 - 5.4. інформування про правила та умови щодо організації навчання освітньої послуги, її якості та змісту, про його права і обов'язки під час надання та отримання освітньої послуги;
 - 5.5. Замовник має права, передбачені статтею 62 Закону України "Про вищу освіту"

ПЛАТА ЗА НАДАВАННЯ ОСВІТНІХ ПОСЛУГ ТА ПОРЯДОК РОЗРАХУНКІВ

- 6. Розмір плати за надання освітньої послуги встановлюється в доларах США (USD), при цьому виконавець має право змінювати розмір плати за навчання не частіше одного разу на рік і не більше як на офіційно визначений рівень інфляції за попередній календарний рік з обов'язковим інформуванням про це замовника.
- 7. Загальна вартість освітньої послуги за весь строк навчання (без урахування інфляції) складає 10400 доларів США (USD)
- 8. Вартість першого року навчання (12 місяців) складає 2600 (два тисячі шістьсот) доларів США (USD) (сума цифрами й словами)
- 9. Оплата за договором здійснюється замовником у національній валюті, яка передовується на валютний рахунок КПІ ім. Ігоря Сікорського або у гривнях лістами конвертації за поточним курсом Національного банку України на реєстраційний рахунок Університету в ДКСУ в м. Києві кожного семестру
- 10. Перший внесок за 1-й рік навчання складає не менше 50% вартості освітньої послуги за поточний навчальний рік і сплачується не пізніше 01 жовтня першого року навчання
- 11. Порядок оплати встановлюється у вигляді внесення платежів в обумовлені терміни:

За 1-й рік навчання	<u>1300</u> доларів США (USD) в день реєстрації договору в КПІ ім. Ігоря Сікорського
перший внесок -	<u>1300</u> доларів США (USD) до 01 жовтня першого навчального року
другий внесок -	<u>1300</u> доларів США (USD) до 01 квітня поточного навчального року (решта вартості освітньої послуги за поточний навчальний рік)
За 2-й, 3-й, 4-й роки навчання щорічно:	<u>1300</u> доларів США (USD) до 21 жовтня (не менше 50% вартості освітньої послуги за поточний навчальний рік)
перший внесок -	<u>1300</u> доларів США (USD) до 01 квітня поточного навчального року (решта вартості освітньої послуги за поточний навчальний рік)

- 12. Оплата освітньої послуги вважається здійсненою належним чином у день фактичного зарадування коштів на поточний рахунок Університету.
- 13. Кожен навчальний рік складається з двох семестрів.

ВІДПОВІДАЛЬНІСТЬ СТОРОН

- 14. За невиконання або неналежне виконання умов договору сторони несуть відповідальність, зокрема за винятковим винятком.
- 15. У разі дострокового розірвання договору винніми порушеннями вважаються договірні зобов'язання або ініціатива замовника, у разі виконання замовником (якщо винніми, коли замовник договір розіршує у зв'язку з невиконанням обов'язків, вказаних статтею 63 Закону України "Про вищу освіту") винні, що були внесені замовником як плата за надання освітньої послуги, повертаються йому в обсязі частини послуги, що отримано на дату розірвання договору
- 16. У разі дострокового розірвання договору у зв'язку з порушенням виконавцем договірних зобов'язань або невиконанням замовником зобов'язань, вказаних статтею 63 Закону України "Про вищу освіту", кошти, що були внесені замовником, не повертаються.
- 17. У разі невиконання виконавцем плати замовником в розмірах та в порядку, встановлені в пункті 11. договору, виконавець відраховує замовнику:

second semester in the year 2024-2025.
 4.4. at his own expense, leave the territory of Ukraine and permanent residence within a month after the completion of the training.

- 1. The recipient has the right to demand from the performer:
 - 5.1. provision of educational services at the level of higher education standards (if the law provides state standards for the provision of educational services);
 - 5.2. ensuring the observance of his rights;
 - 5.3. issuing to the recipient of the document on higher education (scientific degree) of the state standard (if according to the legislation the educational program provides for the issuance of such a document), provided that the recipient completes the curriculum to the extent necessary for obtaining a certain degree of higher education;
 - 5.4. informing about the rules and requirements regarding the organization of the provision of educational services, their quality and content, his rights and obligations when providing and receiving the specified service.
 - 5.5. The recipient has the rights stipulated by Article 62 of the Law of Ukraine "On Higher Education"

PAYMENT FOR THE PROVISION OF EDUCATIONAL SERVICES AND THE PROCEDURE OF PAYMENT

- 6. The amount of payment for the provision of educational services is set in USD, the performer has the right to change the amount of tuition fees no more than once a year and for no more than the officially determined level of inflation for the previous calendar year with the obligatory informing about this of the customer
- 7. The total cost of an educational service for the whole period of study (excluding inflation) is 10400 USD
- 8. The cost for the first year of study (12 months) is 2600 USD
- 9. Payment by the agreement is made by the recipient in freely convertible currency, which is transferred to the currency account of the Igor Sikorsky KPI or in UAH after converting at the current currency exchange rate of the National Bank of Ukraine to the registration account of the University at the State Treasury Service of Ukraine in Kyiv for each semester
- 10. The first payment for the 1st year of training is at least 50% of the cost of the educational service for the current academic year and will be paid no later than October 1 of the first year of study
- 11. The order of payment is established in the form of making payments in due time:

For the 1st year of training	<u>1300</u> USD on the day of the agreement registration in the Igor Sikorsky KPI
First payment -	<u>1300</u> USD before October 1 of the first training year
Second payment -	<u>1300</u> USD before April 1 of the current training year (the rest of price for educational service for the current training year)
For the 2nd, 3rd, 4th years of training annually:	<u>1300</u> USD before October 21 (not less than 50% of the price for educational service for the current training year)
First payment	<u>1300</u> USD before April 1 of the current training year (the rest of price for educational service for the current training year)
Second payment	<u>1300</u> USD before April 1 of the current training year (the rest of price for educational service for the current training year)

- 12. The payment for educational services is considered to be done properly on the day of actual transfer of funds to the current account of the University
- 13. Each academic year consists of two semesters.

RESPONSIBILITY OF THE PARTIES

- 14. For non-fulfillment or improper performance of obligations under the agreement, the parties are liable in accordance with the legislation of Ukraine and the agreement.
- 15. In the event of early termination of the agreement as a result of violations of the performer's obligations or on the initiative of the recipient, in case of sending down of the recipient of the educational service (except for cases when the recipient is sent down in connection with failure to perform the duties specified in Article 63 of the Law of Ukraine "On Higher Education") funds paid by the recipient as fee for the provision of educational services are returned to him in the amount of the payment for part of the service not provided on the date of termination of the agreement
- 16. In the event of early termination of the agreement due to violation of the agreement by the recipient or failure by the recipient of the duties specified in Article 63 of the Law of Ukraine "On Higher Education", the funds, which were paid by the recipient, are not returned.
- 17. In case of late payments of tuition fees by the recipient in the amounts and in the order specified in clause 11 of the agreement, the performer sends down the

TRUE COPY

РОЗРВАННЯ ДОГОВОРУ

- 18. Договір розривається:
 - 18.1. за взаємною згодою;
 - 18.2. у разі неможливості виконання сторонами договору своїх зобов'язань у зв'язку з прийняттям нормативно-правових актів, що змінили умови, встановлені договором щодо освітніх послуг;
 - 18.3. у разі порушення з початкового закладу замовника згідно з повноваженнями та умови договору;
 - 18.4. за рішенням суду.

ПОРЯДОК ВИРІШЕННЯ СПОРІВ

- 19. Усі спори, що виникають з договору або пов'язані з ним, вирішуються шляхом переговорів, а в разі не досягнення згоди – в судовому порядку за законодавством України в місцевому загальному суді (Судовий округ Київський районний суд м. Києва).

ІНШІ УМОВИ

- 20. Договір набуває чинності з моменту його підписання сторонами і діє до повного його виконання.
- 21. Договір складається українською та англійською мовами у 2-х примірниках, які мають однакову юридичну силу.
- 22. Оплата за проживання та надання медичних послуг не включена у вартість договору. В регламентується окремими угодами (договорами).
- 23. Виконавець несе витрати на отримання медичного обслуговування, а також в укладенні договорів на надання медичної допомоги.
- 24. Виконавець не несе витрат, пов'язаних з реєстрацією паспортів або документів, що його замовець (оформленням посвідки на тимчасове проживання), оформленням віз та проїзду замовника до країни постійного проживання у всіх випадках, а також його особистих поїздок територією України та за кордон.
- 25. Виконавець не бере на себе зобов'язань щодо страхування життя та майна замовника.
- 26. У разі смерті замовника виконавець не несе витрат, пов'язаних з транспортуванням тіла.
- 27. Внесення змін та доповнень до договору допускається виключно шляхом укладення додаткової угоди в письмовій формі за підписами сторін.

TERMINATION OF THE AGREEMENT

- 18. The agreement can be terminated:
 - 18.1 by mutual consent,
 - 18.2 in case of impossibility of fulfillment of obligations by the party in connection with the adoption of regulatory acts that changed the conditions established by the agreement on educational services and disagreement of any of the parties to amend the agreement,
 - 18.3 in case of sending down of the recipient in accordance with the law of Ukraine and the terms of the agreement.
 - 18.4 by court decision.

PROCEDURE FOR SOLVING DISPUTES

- 19. Disputes arising out of or related to this agreement shall be resolved through negotiations, and in case of failure to reach agreement, in court according to the legislation of Ukraine in the local general court (Kyivanytsky District Court in Kyiv).

OTHER CONDITIONS

- 20. The agreement enters into force from the moment of its signing by the parties and operates until its complete fulfillment.
- 21. The agreement is signed in Ukrainian and English in 2 (two) copies each, one copy for each party, which have the same legal force.
- 22. Payment for accommodation and provision of medical services is not included in the cost of education and is regulated by separate agreements (contracts).
- 23. Performer assists the recipient in obtaining medical care, as well as in the conclusion of contracts for the provision of medical care.
- 24. The performer does not bear the costs associated with the registration of a passport or a document that replaces it (registration of a temporary residence permit), visa registration and travel to the country of permanent residence in all cases, as well as his personal travel within the territory of Ukraine and abroad.
- 25. The performer does not assume any obligations regarding the life and property insurance of the recipient.
- 26. In the case of death of the recipient, the performer does not bear the costs associated with the transportation of the body.
- 27. Amendments and additions to the agreement are permissible only by concluding an additional agreement in writing signed by the parties.

**МІСЦЕЗНАХОДЖЕННЯ ТА РЕКВІЗИТИ СТОРІН / LOCATION AND DETAILS OF THE PARTIES
ВИКОНАВЕЦЬ / PERFORMER**

Найменування, адреса, телефон / Name, address, phone	Реквізити / Details	Підписи / Signatures
Національний технічний університет України "Київський політехнічний інститут імені Ігоря Сікорського" Адреса: 03056, Україна, м. Київ, пр-т Перемоги, 37 E-mail: sto-dekalan@kpi.ua Телефон/факс: +380(44) 236-10-63 Телефон: +380(44) 204-86-58 National Technical University of Ukraine "Igor Sikorsky Kyiv Polytechnical Institute" Address: 37, Peremohy Avenue, Kyiv, 03056, Ukraine E-mail: sto-dekalan@kpi.ua tel./fax: +380(44) 236-10-63 tel.: +380(44) 204-86-58	Директор / Director Виконавець / Performer І. С. Ковал І. С. Ковал І. С. Ковал	Ю. І. Якуменко Yu. Yakymenko І. С. Ковал V. Koval Марковий керівник / Scientific supervisor І. С. Ковал І. С. Ковал

ЗАМОВНИК / RECIPIENT

ПІБ, адреса, телефон / Name, address, phone	Підписи / Signatures
ПІБ / Surname, name: <u>Mane kishor Vishwanath</u> Адреса / Address: <u>VIMEET, Survey No 62, Kumbhivali, 410202</u> Паспорт / Passport: <u>R9242459</u> <u>Khalapur, India</u> Телефон / Phone: <u>(+91) 9561779610</u> / <u>(+380) 977572028</u> E-mail: <u>Manek V 556 @gmail.com</u>	Підписи / Signatures: Мане Кішор Вішванат Мане Кішор Вішванат Мане Кішор Вішванат

TRUE COPY
 Вішванат Мане (VIMEET)

1.1. Сторонами цього договору є:

1.2. Сторонами цього договору є:

- 1.3. Цей договір є грошовою угодою.
- 1.4. Сторонами цього договору є:
- 1.5. Цей договір є грошовою угодою.
- 1.6. Сторонами цього договору є:
- 1.7. Цей договір є грошовою угодою.
- 1.8. Сторонами цього договору є:
- 1.9. Цей договір є грошовою угодою.
- 1.10. Сторонами цього договору є:
- 1.11. Цей договір є грошовою угодою.
- 1.12. Сторонами цього договору є:
- 1.13. Цей договір є грошовою угодою.
- 1.14. Сторонами цього договору є:
- 1.15. Цей договір є грошовою угодою.
- 1.16. Сторонами цього договору є:
- 1.17. Цей договір є грошовою угодою.
- 1.18. Сторонами цього договору є:
- 1.19. Цей договір є грошовою угодою.
- 1.20. Сторонами цього договору є:
- 1.21. Цей договір є грошовою угодою.
- 1.22. Сторонами цього договору є:
- 1.23. Цей договір є грошовою угодою.
- 1.24. Сторонами цього договору є:
- 1.25. Цей договір є грошовою угодою.

ПЛАТА ЗА НАДААННЯ ОБРАЗОВИХ ПОСЛУГ ТА ПОРЯДОК РОЗРАХУНКІВ

1. Цей договір є грошовою угодою.
2. Сторонами цього договору є:
3. Цей договір є грошовою угодою.
4. Сторонами цього договору є:
5. Цей договір є грошовою угодою.
6. Сторонами цього договору є:
7. Цей договір є грошовою угодою.
8. Сторонами цього договору є:
9. Цей договір є грошовою угодою.
10. Сторонами цього договору є:
11. Цей договір є грошовою угодою.
12. Сторонами цього договору є:
13. Цей договір є грошовою угодою.
14. Сторонами цього договору є:
15. Цей договір є грошовою угодою.
16. Сторонами цього договору є:
17. Цей договір є грошовою угодою.
18. Сторонами цього договору є:
19. Цей договір є грошовою угодою.
20. Сторонами цього договору є:
21. Цей договір є грошовою угодою.
22. Сторонами цього договору є:
23. Цей договір є грошовою угодою.
24. Сторонами цього договору є:
25. Цей договір є грошовою угодою.

За 1-й рік навчання	1300 доларів США (USD) у день реєстрації договору в КПП ім. Ігоря Сікорського.
перший внесок	1300 доларів США (USD) до 01 жовтня першого навчального року
другий внесок	1300 доларів США (USD) до 01 квітня навчального навчального року (решта вартості освітньої послуги за поточний навчальний рік)
За 2-й, 3-й, 4-й роки навчання доприче:	1300 доларів США (USD) до 21 жовтня (не менш 50% вартості освітньої послуги за поточний навчальний рік)
перший внесок	1300 доларів США (USD) до 01 квітня поточного навчального року (решта вартості освітньої послуги за поточний навчальний рік)
другий внесок	

12. Оплата освітніх послуг здійснюється відповідно до умов цього договору.
13. Кожен навчальний рік складається з двох семестрів.

ВІДПОВІДАЛЬНІСТЬ СТОРИН

14. За невиконання або неналежне виконання умов договору сторона несе відповідальність, визначену законодавством України.
15. У разі невиконання сторонами умов договору порушення зобов'язань сторони здійснюється шляхом стягнення з боку сторони відповідно до умов цього договору.
16. У разі невиконання сторонами умов договору порушення зобов'язань сторони здійснюється шляхом стягнення з боку сторони відповідно до умов цього договору.
17. У разі невиконання сторонами умов договору порушення зобов'язань сторони здійснюється шляхом стягнення з боку сторони відповідно до умов цього договору.

1.1. Сторонами цього договору є:

1.2. Сторонами цього договору є:

- 1.3. Цей договір є грошовою угодою.
- 1.4. Сторонами цього договору є:
- 1.5. Цей договір є грошовою угодою.
- 1.6. Сторонами цього договору є:
- 1.7. Цей договір є грошовою угодою.
- 1.8. Сторонами цього договору є:
- 1.9. Цей договір є грошовою угодою.
- 1.10. Сторонами цього договору є:
- 1.11. Цей договір є грошовою угодою.
- 1.12. Сторонами цього договору є:
- 1.13. Цей договір є грошовою угодою.
- 1.14. Сторонами цього договору є:
- 1.15. Цей договір є грошовою угодою.
- 1.16. Сторонами цього договору є:
- 1.17. Цей договір є грошовою угодою.
- 1.18. Сторонами цього договору є:
- 1.19. Цей договір є грошовою угодою.
- 1.20. Сторонами цього договору є:
- 1.21. Цей договір є грошовою угодою.
- 1.22. Сторонами цього договору є:
- 1.23. Цей договір є грошовою угодою.
- 1.24. Сторонами цього договору є:
- 1.25. Цей договір є грошовою угодою.

PAYMENT FOR THE PROVISION OF EDUCATIONAL SERVICES AND THE PROCEDURE OF PAYMENT

1. The amount of payment for the provision of educational services is determined by the performer has the right to change the amount of payment once a year and for no more than the officially determined level.
2. The total cost of an educational service for the whole period of study (excluding tuition) is 1300 USD.
3. The cost for the first year of study (12 months) is 1300 USD.
4. Payment by the agreement is made by the recipient in local currency, which is transferred to the currency account of the Igor Sikorsky KPI in UAH after converting at the current currency exchange rate of the National Bank of Ukraine to the registration account of the University in the State Treasury Service of Ukraine in Kyiv for each semester.
5. The first payment for the 1st year of training is at least 50% of the cost of the educational service for the current academic year and will be paid no later than October 1 of the first year of study.
6. The order of payment is established in the form of making payments in due time.

For the 1st year of training	1300 USD on the day of the agreement registration in the Igor Sikorsky KPI
First payment	1300 USD before October 1 of the first training year
Second payment	1300 USD before April 1 of the current training year (the rest of price for educational service for the current training year)
For the 2nd, 3rd, 4th years of training	1300 USD before October 21 just less than 50% of the price for educational service for the current training year
First payment	
Second payment	1300 USD before April 1 of the current training year (the rest of price for educational service for the current training year)

12. The payment for educational services is considered to be done properly, on the day of actual transfer of funds to the current account of the University.
13. Each academic year consists of two semesters.

RESPONSIBILITY OF THE PARTIES

14. For non-fulfillment or improper performance of obligations under the agreement, the parties are liable in accordance with the legislation of Ukraine and the agreement.
15. In the event of early termination of the agreement as a result of violation of the performer's obligations or on the initiative of the recipient, in case of sending down of the recipient of the educational service (except for cases when the recipient is sent down in connection with failure to perform the duties specified in Article 63 of the Law of Ukraine "On Higher Education") funds paid by the recipient are for the provision of educational services are returned to him in the amount of the payment for part of the service not provided on the date of termination of the agreement.
16. In the event of early termination of the agreement due to violation of the agreement by the recipient or failure by the recipient of the duties specified in Article 63 of the Law of Ukraine "On Higher Education", the funds, which were paid by the recipient, are not returned.
17. In case of late payment of tuition fees by the recipient in the amount and in the order specified in point 11 of the agreement, the performer sends down the recipient.

TRUE COPY
 P. H. H. H.
 Vishwathirayan's (HMEET)

AGREEMENT (A. 11) No. 14/10/19
 Про надання освітніх послуг закордонним студентам і докторантам іноземного походження
 for providing educational services for postgraduate students, doctoral students - foreign citizens

м. Київ, 2019

№ 14/10/19
 від 2 жовт. 2019 р.р.

Учасниками цього угоди є **ІГОР СИКОРСЬКИЙ НАУКОВО-ДИДАКТИЧНИЙ ЦЕНТР НАЦІОНАЛЬНОГО УНІВЕРСИТЕТУ ІГОР СИКОРСЬКОГО НАЦІОНАЛЬНОГО УНІВЕРСИТЕТУ**
IGOR SYKORSKY SCIENTIFIC AND DIDACTIC CENTER NATIONAL UNIVERSITY OF IGOR SYKORSKY

НАЦІОНАЛЬНИЙ УНІВЕРСИТЕТ ІГОР СИКОРСЬКОГО НАЦІОНАЛЬНОГО УНІВЕРСИТЕТУ
NATIONAL UNIVERSITY OF IGOR SYKORSKY

public limited liability company with the status of Ukraine and
 registered in Ukraine

або **ІГОР СИКОРСЬКИЙ НАУКОВО-ДИДАКТИЧНИЙ ЦЕНТР НАЦІОНАЛЬНОГО УНІВЕРСИТЕТУ ІГОР СИКОРСЬКОГО НАЦІОНАЛЬНОГО УНІВЕРСИТЕТУ**
 or **IGOR SYKORSKY SCIENTIFIC AND DIDACTIC CENTER NATIONAL UNIVERSITY OF IGOR SYKORSKY**

at the terms of the first paragraph of this Agreement, in accordance with the Statute of Igor Sikorsky Scientific and Didactic Center of National University of Igor Sikorsky, the addressee, as the first party, and

НАЦІОНАЛЬНИЙ УНІВЕРСИТЕТ ІГОР СИКОРСЬКОГО НАЦІОНАЛЬНОГО УНІВЕРСИТЕТУ
NATIONAL UNIVERSITY OF IGOR SYKORSKY

(hereinafter - the recipient), as the second party, together. The parties and each separately, the party, have concluded this agreement on providing educational services for postgraduate students, doctoral students - foreign citizens (hereinafter referred to in the agreement) on the following:

SUBJECT OF THE AGREEMENT

1. The subject of the agreement is the provision of educational services. The performer undertakes at the expense of the recipient to provide an educational service, namely:

ПРЕДМЕТ УГОДИ
 Ця угода є угодою надання освітньої послуги. Виконавець зобов'язується надати освітню послугу на умовах угоди за рахунок замовника іноземного походження надання освітньої послуги, а саме:

освітня послуга	підготовка докторантів-студентів доктора філософії
форма навчання	очно
строк надання освітньої послуги	21.10.2019 – 20.10.2023
ступінь вищої освіти	доктор філософії
код спеціальності/освітньої програми/спеціалізації	173 «Авіація» ІАТ
обсяг освітньої послуги/обсяг надання освітньої послуги в кредитній трансферно-кваліфікаційній системі	

Educational service	PhD training
Form of training	Part-time training
Duration of service provision	21.10.2019 - 20.10.2023
Level of higher education	PhD
Name of specialty/educational program/specialization	173 "Aviation" IAT
the volume of the higher education or ECTS Credits	

1.1. Місцем виконання угоди (надання освітньої послуги) є проспект Перемоги, 27, м. Київ.
 1.2. Замовник вступив до КПП м. Ігоря Сікорського іноземного походження України та нормативної бази КПП м. Ігоря Сікорського.

1.1. The place of the agreement execution (provision of the service) is 27, Peremohy Avenue, Kyiv, Ukraine.

1.2. The recipient enters the Igor Sikorsky KPP according to the legislation of Ukraine and the normative base of the Igor Sikorsky KPP.

ОБОВ'ЯЗКИ ТА ПРАВА ВИКОНАВЦІ

- Виконавець зобов'язаний:
 - надати замовнику освітню послугу на рівні стандартів вищої освіти (або на рівні стандартів передбачено державні стандарти вищої освіти (освітньої послуги));
 - забезпечити виконання умов замовника;
 - інформувати замовника про правила та умови надання освітньої послуги, а також та інші, що стосуються надання освітньої послуги;
 - надати замовнику документи про рівень освіти (освітньої ступінь) відповідно до вимог законодавства та відповідних програмних документів вищої освіти (освітньої послуги) за умов виконання обов'язків виконавця відповідно до умов угоди, передбаченої або встановленої державними стандартами.
- Виконавець має право:
 - вимагати від замовника відповідно вносити плату за надання послуги в розмірах та в порядку, встановленому договором;
 - вимагати від замовника за освітні послуги або освітні послуги в інших законодавств України та умов договору, а також інші документи, необхідні для виконання умов угоди.

ОBLIGATIONS AND THE RIGHTS OF THE PERFORMER

- The performer shall:
 - provide the recipient with an education service at the level of higher education standards (if the law provides for state standards for the provision of educational services);
 - ensure compliance with recipient rights;
 - inform the recipient about the rules and requirements regarding the organization of the provision of educational services, their quality and content, his rights and obligations when receiving the educational service;
 - issue a document on the higher education (scientific degree) of the user standard if in accordance with the legislation, the educational program provides for the issuance of such document), provided that the recipient complies the requirements in the amount necessary for obtaining a certain degree of higher education.
- The performer has the right:
 - to demand from the recipient timely payment for the educational service in the amount and in the order established by the agreement;
 - to demand from the recipient for failure or improper fulfillment of the requirements of the legislation of Ukraine and the terms of the agreement, including the missing the terms of payment of the fees for the educational service the evidence.

ОБОВ'ЯЗКИ ТА ПРАВА ЗАМОВНИКА

- Замовник зобов'язаний:
 - здійснювати відповідно плати за освітні послуги в розмірах та в порядку, встановленому договором;
 - дотримуватися обов'язків виконавця відповідно до умов угоди, передбаченої державними стандартами вищої освіти (освітньої послуги) та умов договору, а також інших законодавств України та умов договору, а також інших документів, необхідних для виконання умов угоди, передбаченої державними стандартами вищої освіти (освітньої послуги) та умов договору, а також інших законодавств України та умов договору, а також інших документів, необхідних для виконання умов угоди.

DUTIES AND THE RIGHTS OF THE RECIPIENT

- The recipient is obliged to:
 - pay the fee for educational services in the amount and in the manner established by the agreement;
 - comply with the terms stipulated in Article 6 of the Law of Ukraine "On Higher Education", with other requirements of the legislation of Ukraine, the Charter of the Igor Sikorsky KPP, Regulations on the organization of the educational process of the Igor Sikorsky KPP, Rules of the Internal Regulations of the Igor Sikorsky KPP, Code of Honor of the Igor Sikorsky KPP and other normative acts of the Igor Sikorsky KPP;
 - notify the education documents submitted in the entrance (the educational document of or the level of education received by the recipient) before the

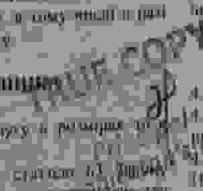

1.1. Назначение: «Служба поддержки клиентов»

- 1.2. Цель: «Создание единого центра поддержки клиентов и повышение качества обслуживания клиентов»
- 1.3. Вид работ: «Обеспечение комплексного обслуживания клиентов»

- 1.4. Вид работ: «Обеспечение комплексного обслуживания клиентов»
- 1.5. Место выполнения работ: «Украина, г. Киев, ул. Майдан Незалежності, 1»
- 1.6. Срок выполнения работ: «Срок выполнения работ: 12 месяцев с даты подписания настоящего Договора»
- 1.7. Ответственность за выполнение работ: «Исполнитель несет ответственность за выполнение работ в соответствии с условиями настоящего Договора»
- 1.8. Ответственность за предоставление информации: «За предоставление информации несет ответственность Заказчик»
- 1.9. Ответственность за предоставление информации: «За предоставление информации несет ответственность Заказчик»
- 1.10. Ответственность за предоставление информации: «За предоставление информации несет ответственность Заказчик»
- 1.11. Ответственность за предоставление информации: «За предоставление информации несет ответственность Заказчик»
- 1.12. Ответственность за предоставление информации: «За предоставление информации несет ответственность Заказчик»
- 1.13. Ответственность за предоставление информации: «За предоставление информации несет ответственность Заказчик»
- 1.14. Ответственность за предоставление информации: «За предоставление информации несет ответственность Заказчик»
- 1.15. Ответственность за предоставление информации: «За предоставление информации несет ответственность Заказчик»

УМОВИ НАСТАВНИЦЬКИХ УСЛУГ НАСКОМУ ТА ПОРЯДОК ПЛАТІВАННЯ

- 6. Показатель качества выполнения работ: «Качество выполнения работ по показателю качества выполнения работ: «Качество выполнения работ по показателю качества выполнения работ»
- 7. Порядок оплаты: «Порядок оплаты: «Порядок оплаты: «Порядок оплаты»
- 8. Порядок оплаты: «Порядок оплаты: «Порядок оплаты: «Порядок оплаты»
- 9. Оплата за обучение: «Оплата за обучение: «Оплата за обучение: «Оплата за обучение»
- 10. Порядок оплаты: «Порядок оплаты: «Порядок оплаты: «Порядок оплаты»
- 11. Порядок оплаты: «Порядок оплаты: «Порядок оплаты: «Порядок оплаты»
- 12. Порядок оплаты: «Порядок оплаты: «Порядок оплаты: «Порядок оплаты»
- 13. Порядок оплаты: «Порядок оплаты: «Порядок оплаты: «Порядок оплаты»
- 14. Порядок оплаты: «Порядок оплаты: «Порядок оплаты: «Порядок оплаты»
- 15. Порядок оплаты: «Порядок оплаты: «Порядок оплаты: «Порядок оплаты»

За 1-й рік навчання	1300 доларів США (USD) в день реєстрації договору в КНП ім. Ігара Сікорського
перший платеж -	1300 доларів США (USD) до 01 жовтня першого навчального року
другий платеж -	1300 доларів США (USD) до 01 квітня поточного навчального року (протяг періоду оплати поділити на відповідні навчальні роки)
За 2-й, 3-й, 4-й роки навчання (періодичні платежі)	1300 доларів США (USD) до 01 жовтня (не менше 50% вартості) відповідно поділити на відповідні навчальні роки
другий платеж -	1300 доларів США (USD) до 01 квітня поточного навчального року (протяг періоду оплати поділити на відповідні навчальні роки)

12. Оплата за навчання здійснюється відповідними банківськими переказами на фінансовий рахунок банку ім. обласного радиусу Університету

13. Коштові навчальні матеріали надає з повної відповідальністю

ВІДПОВІДАЛЬНІСТЬ СТОРОН

- 14. За невиконання або неналежне виконання умов договору сторонам нести відповідальність, визначену законодавством України.
- 15. У разі дострокового розірвання договору виконавець несе відповідальність за виконання умов договору згідно з умовами цього Договору.
- 16. У разі дострокового розірвання договору виконавець несе відповідальність за виконання умов договору згідно з умовами цього Договору.
- 17. У разі дострокового розірвання договору виконавець несе відповідальність за виконання умов договору згідно з умовами цього Договору.

1.1. Назначение: «Служба поддержки клиентов»

1.2. Цель: «Создание единого центра поддержки клиентов и повышение качества обслуживания клиентов»

- 1.4. Вид работ: «Обеспечение комплексного обслуживания клиентов»
- 1.5. Место выполнения работ: «Украина, г. Киев, ул. Майдан Незалежності, 1»
- 1.6. Срок выполнения работ: «Срок выполнения работ: 12 месяцев с даты подписания настоящего Договора»
- 1.7. Ответственность за выполнение работ: «Исполнитель несет ответственность за выполнение работ в соответствии с условиями настоящего Договора»
- 1.8. Ответственность за предоставление информации: «За предоставление информации несет ответственность Заказчик»
- 1.9. Ответственность за предоставление информации: «За предоставление информации несет ответственность Заказчик»
- 1.10. Ответственность за предоставление информации: «За предоставление информации несет ответственность Заказчик»
- 1.11. Ответственность за предоставление информации: «За предоставление информации несет ответственность Заказчик»
- 1.12. Ответственность за предоставление информации: «За предоставление информации несет ответственность Заказчик»
- 1.13. Ответственность за предоставление информации: «За предоставление информации несет ответственность Заказчик»
- 1.14. Ответственность за предоставление информации: «За предоставление информации несет ответственность Заказчик»
- 1.15. Ответственность за предоставление информации: «За предоставление информации несет ответственность Заказчик»

PAYMENT FOR THE PROVISION OF EDUCATIONAL SERVICES AND THE PROCEDURE OF PAYMENT

- 6. The amount of payment for the provision of educational services is set in USD. The performer has the right to change the amount of tuition fees no more than once a year and by no more than the officially determined level of inflation for the previous calendar year with the obligatory informing about this of the customer.
- 7. The total cost of an educational service for the whole period of study (including inflation) is _____ USD.
- 8. The cost for the first year of study (12 months) is _____ USD.
- 9. Payment by the agreement is made by the recipient in freely convertible currency, which is transferred to the currency account of the Igor Sikorsky KPI or by USD after converting at the current currency exchange rate of the National Bank of Ukraine in the registration account of the University at the State Treasury Service of Ukraine in Kyiv for each semester.
- 10. The first payment for the 1st year of learning is at least 50% of the cost of the educational service for the current academic year and will be paid no later than October 1 of the first year of study.
- 11. The order of payment is established in the form of making payments in due time.

For the 1st year of training	1300 USD on the day of the agreement registration in the Igor Sikorsky KPI
First payment -	1300 USD before October 1 of the first training year
Second payment -	1300 USD before April 1 of the current training year (the rest of price for educational service for the current training year)
For the 2nd, 3rd, 4th years of learning annually	1300 USD before October 31 (not less than 50% of the price for educational service for the current training year)
First payment	
Second payment	1300 USD before April 1 of the current training year (the rest of price for educational service for the current training year)

12. The payment for educational services is considered to be done properly on the day of actual transfer of funds to the current account of the University

13. Each academic year consists of two semesters

RESPONSIBILITY OF THE PARTIES

- 14. For non-fulfillment or improper performance of obligations under the agreement, the parties will be liable in accordance with the legislation of Ukraine and the agreement.
- 15. In the event of early termination of the agreement as a result of violation of the performer's obligations or on the initiative of the recipient in case of learning more of the recipient of the educational service (except for cases when the recipient is not allowed to continue to fulfill to perform the duties specified in Article 61 of the Law of Ukraine "On Higher Education") funds paid by the recipient for the provision of educational services are returned to him in the amount of the payment for the part of the amount not provided in the time of termination of the agreement.
- 16. In the event of early termination of the agreement due to violation of the agreement by the recipient or failure by the recipient of the duties specified in Article 61 of the Law of Ukraine "On Higher Education", the funds, which were paid by the recipient, are not returned.
- 17. In case of late payment of tuition fees by the recipient in the accounts and in the order specified in clause 11 of the agreement, the performer sends due the recipient.

TRUE COPY

PERFORMING AGENCY

18. For each participant in a
 - 18.1. a first review
 - 18.2. a final review unless otherwise specified in the agreement with a party to the review the Department may, at the discretion of the Department, be conducted by the Department.
 - 18.3. a final review unless otherwise specified in the agreement with a party to the review.
 - 18.4. a participant's case.

APPLICABLE INSTRUMENTS AND CODES

19. For each law, regulation, or agreement that has been in force during the period of the review, the Department may, at the discretion of the Department, be conducted by the Department.

UNIT NUMBER

20. The review shall be conducted in accordance with the provisions of the agreement with a party to the review.
21. The review shall be conducted in accordance with the provisions of the agreement with a party to the review.
22. The review shall be conducted in accordance with the provisions of the agreement with a party to the review.
23. The review shall be conducted in accordance with the provisions of the agreement with a party to the review.
24. The review shall be conducted in accordance with the provisions of the agreement with a party to the review.
25. The review shall be conducted in accordance with the provisions of the agreement with a party to the review.
26. The review shall be conducted in accordance with the provisions of the agreement with a party to the review.
27. The review shall be conducted in accordance with the provisions of the agreement with a party to the review.
28. The review shall be conducted in accordance with the provisions of the agreement with a party to the review.
29. The review shall be conducted in accordance with the provisions of the agreement with a party to the review.
30. The review shall be conducted in accordance with the provisions of the agreement with a party to the review.

НАМЕНОВАНИЕ ТА ПЕРИОД СТОИМ/LOCATION AND DETAILS OF THE PARTIES
ИМХОМАНБИЛ/RESPONSIBLE

Надлежноста, адреса, статусот / Name, address, status Информациони / Informational	Период / Details	Планово / Signature
<p>Адреса: Елџа, Вашингтон на Каџа 11-1 / Washington, DC Контакт: 1800441234-0-60 Телефон: 440141234-0-60</p> <p>National Technical University of Ukraine Kyiv Shcherbyi Kyiv Polytechnical Institute Address: 57 Chernobyl Avenue, Kyiv, 01009, Ukraine E-mail: en@ukr.net +380441234-0-60 +380441234-0-60</p>		<p>Директор / Director B. Kovaleva V. Kovaleva</p> <p>Научен експерт / Scientific supervisor </p>



ИМХОМАНБИЛ/RESPONSIBLE	Планово / Signature
<p>ИМХОМАНБИЛ: WASH SHARRAD SHEKHAR Адрес: 8202, RH-3, DOORWAY 11E3, INDIA Телефон: 32986377 Контакт: 438-077577616 and 431-7722067665</p> <p>ИМХОМАНБИЛ: VISHWANATHAN Контакт: 85505976 @ vishwanathan.edu.in</p>	<p>Научен експерт / Scientific supervisor </p>

31. The review shall be conducted in accordance with the provisions of the agreement with a party to the review.
32. The review shall be conducted in accordance with the provisions of the agreement with a party to the review.
33. The review shall be conducted in accordance with the provisions of the agreement with a party to the review.
34. The review shall be conducted in accordance with the provisions of the agreement with a party to the review.
35. The review shall be conducted in accordance with the provisions of the agreement with a party to the review.
36. The review shall be conducted in accordance with the provisions of the agreement with a party to the review.
37. The review shall be conducted in accordance with the provisions of the agreement with a party to the review.
38. The review shall be conducted in accordance with the provisions of the agreement with a party to the review.
39. The review shall be conducted in accordance with the provisions of the agreement with a party to the review.
40. The review shall be conducted in accordance with the provisions of the agreement with a party to the review.
41. The review shall be conducted in accordance with the provisions of the agreement with a party to the review.
42. The review shall be conducted in accordance with the provisions of the agreement with a party to the review.
43. The review shall be conducted in accordance with the provisions of the agreement with a party to the review.
44. The review shall be conducted in accordance with the provisions of the agreement with a party to the review.
45. The review shall be conducted in accordance with the provisions of the agreement with a party to the review.
46. The review shall be conducted in accordance with the provisions of the agreement with a party to the review.
47. The review shall be conducted in accordance with the provisions of the agreement with a party to the review.
48. The review shall be conducted in accordance with the provisions of the agreement with a party to the review.
49. The review shall be conducted in accordance with the provisions of the agreement with a party to the review.
50. The review shall be conducted in accordance with the provisions of the agreement with a party to the review.
51. The review shall be conducted in accordance with the provisions of the agreement with a party to the review.
52. The review shall be conducted in accordance with the provisions of the agreement with a party to the review.
53. The review shall be conducted in accordance with the provisions of the agreement with a party to the review.
54. The review shall be conducted in accordance with the provisions of the agreement with a party to the review.
55. The review shall be conducted in accordance with the provisions of the agreement with a party to the review.
56. The review shall be conducted in accordance with the provisions of the agreement with a party to the review.
57. The review shall be conducted in accordance with the provisions of the agreement with a party to the review.
58. The review shall be conducted in accordance with the provisions of the agreement with a party to the review.
59. The review shall be conducted in accordance with the provisions of the agreement with a party to the review.
60. The review shall be conducted in accordance with the provisions of the agreement with a party to the review.
61. The review shall be conducted in accordance with the provisions of the agreement with a party to the review.
62. The review shall be conducted in accordance with the provisions of the agreement with a party to the review.
63. The review shall be conducted in accordance with the provisions of the agreement with a party to the review.
64. The review shall be conducted in accordance with the provisions of the agreement with a party to the review.
65. The review shall be conducted in accordance with the provisions of the agreement with a party to the review.
66. The review shall be conducted in accordance with the provisions of the agreement with a party to the review.
67. The review shall be conducted in accordance with the provisions of the agreement with a party to the review.
68. The review shall be conducted in accordance with the provisions of the agreement with a party to the review.
69. The review shall be conducted in accordance with the provisions of the agreement with a party to the review.
70. The review shall be conducted in accordance with the provisions of the agreement with a party to the review.
71. The review shall be conducted in accordance with the provisions of the agreement with a party to the review.
72. The review shall be conducted in accordance with the provisions of the agreement with a party to the review.
73. The review shall be conducted in accordance with the provisions of the agreement with a party to the review.
74. The review shall be conducted in accordance with the provisions of the agreement with a party to the review.
75. The review shall be conducted in accordance with the provisions of the agreement with a party to the review.
76. The review shall be conducted in accordance with the provisions of the agreement with a party to the review.
77. The review shall be conducted in accordance with the provisions of the agreement with a party to the review.
78. The review shall be conducted in accordance with the provisions of the agreement with a party to the review.
79. The review shall be conducted in accordance with the provisions of the agreement with a party to the review.
80. The review shall be conducted in accordance with the provisions of the agreement with a party to the review.
81. The review shall be conducted in accordance with the provisions of the agreement with a party to the review.
82. The review shall be conducted in accordance with the provisions of the agreement with a party to the review.
83. The review shall be conducted in accordance with the provisions of the agreement with a party to the review.
84. The review shall be conducted in accordance with the provisions of the agreement with a party to the review.
85. The review shall be conducted in accordance with the provisions of the agreement with a party to the review.
86. The review shall be conducted in accordance with the provisions of the agreement with a party to the review.
87. The review shall be conducted in accordance with the provisions of the agreement with a party to the review.
88. The review shall be conducted in accordance with the provisions of the agreement with a party to the review.
89. The review shall be conducted in accordance with the provisions of the agreement with a party to the review.
90. The review shall be conducted in accordance with the provisions of the agreement with a party to the review.
91. The review shall be conducted in accordance with the provisions of the agreement with a party to the review.
92. The review shall be conducted in accordance with the provisions of the agreement with a party to the review.
93. The review shall be conducted in accordance with the provisions of the agreement with a party to the review.
94. The review shall be conducted in accordance with the provisions of the agreement with a party to the review.
95. The review shall be conducted in accordance with the provisions of the agreement with a party to the review.
96. The review shall be conducted in accordance with the provisions of the agreement with a party to the review.
97. The review shall be conducted in accordance with the provisions of the agreement with a party to the review.
98. The review shall be conducted in accordance with the provisions of the agreement with a party to the review.
99. The review shall be conducted in accordance with the provisions of the agreement with a party to the review.
100. The review shall be conducted in accordance with the provisions of the agreement with a party to the review.

OTHER COMMENTS

Handwritten notes and stamps at the bottom left of the page.

जयेश दत्तात्रेय कालेकर

सिव्हील इंजिनियर

मु.मडवळ, पोस्ट-नेरळ, ता-कर्जत, जि.रायगड- ४१००१ (२९४५७३८९२९)

जाचक क्र ७४४१

दि. 25/04/2019

To whomsoever this may concern

This is to certify that Mr. Rupesh A. Devale has been working with us as a Junior site Engineer under Training in our project, M/S Jayesh Kalekar from 15/12/2018 to 15/04/2019. He has been supervising the work under instructions and the entire satisfaction of project Engineers. We found him honest, punctual and hardworking during service tenure. We also found that he has an enthusiasm to learn more from our site. We wish her all success in him endeavors.



For Jayesh Kalekar

Date-25/04/2019

Partner

Place: Neral

TRUE COPY

Pratik S. Patil
Member of Engineers (MCAET)

MEMORANDUM

Of

UNDERSTANDING

Between

**VISHWANIKETAN'S
iMEET, KUMBHIVALI**

And

**BABA Automobile Pvt.
Ltd., Jaipur
(Training Agency)**

TRUE COPY



Executive Summary

Memorandum of Understanding

Between

BABA Automobile Pvt. Ltd., Jaipur

(Training Agency)

And

Vishwaniketan's VIMEET, Kumbhivall(VIMEET)

1.1 Context:

This MoU is hereby entered into by Vishwaniketan's VIMEET Kumbhivall, Tal, Khalapur to train BABA Automobile Pvt. Ltd., Jaipur (Training Agency) hereinafter referred to as the training agency & the Vishwaniketan's VIMEET, Kumbhivall hereinafter referred to as VIMEET. Collectively all signatories of this MoU will be known as cooperators.

1.2 Purpose

The Purpose of this MoU is to formalize a relationship between the aforementioned institute & training agency for the purpose of cooperating in providing training & educational information & to facilitate the development of students towards industry readiness.

1.3 Objective

The objective of this MoU is to deliver on job training on the specifically mentioned like parts of engine, assembly and dis-assembly, dimensions of automobiles etc. to the students of VIMEET who have enrolled for the On Job training based on industrial problems. This training program for VIMEET covers the curriculum finalized between the two organizations, copies of which with signatures of both parties are enclosed in this agreement.

1.4 Training Agency & VIMEET agree to:

1. VIMEET shall provide the infrastructure for delivering the classroom sessions & lab sessions.
2. Training agency shall provide competent trainers for theory & lab sessions, few specific equipment's/software will also be provided by the training agency.
3. VIMEET shall provide the stay and food arrangement of the Trainer at the institute's Hostel, at the cost as per prevailing norms of the Institute. The installation of the software will be done by the Training agency one day prior to the training schedule.

It is mutually agreed and understood by all Parties that:

The Training agency shall follow the course content and Time Table provided by VIMEET which are attached as Appendix I & II respectively.

TP/10

Contact Details:

College:

Dr. B. R Patil
Principal,
VIMEET, Khalapur,
Bsnar: Dr. Janhavi Inamdar,
Kumbhvali. (02192-274208)

Training Agency:

Mr. Nuresh Baba
HASSA Autotech Pvt. Ltd, Jaipur,
Rajasthan (8769405920)

3.1.1 Commencement/Expiration/Termination:

This MoU takes effect upon the signature of the training agency & VIMEET and shall remain in effect for the particular course from date of execution which will be valid for 01 Years (One Year). This MoU may be extended or amended upon written request of the training agency & subsequent with concurrence of the other party. Any of the parties may terminate this MoU with 30 days written notice to the other party.

3.2 Methodology:

Feedback: The training agency may take feedback of the participants as & when they feel necessary. VIMEET will take feedback from students on regular basis & will inform the trainers about the outcome of the feedback. The suggestions evolved out of this feedback will be MANDATORY on the part of trainers.

3.3 Project:

After completion of the training the training agency must provide a good quality project for each student in the group of (3-4) students and it evaluated by the Industry Experts. It is the sole responsibility of the training agency that 95% students must complete the project.

After completion of training, the training agency shall provide the support for solving the problems for completion of project by skype meeting/Email exchange/ telephonic discussion/college visit.

The trainer must review the project (by physical presence at Vishwaketan's IMEET, Khalapur Campus) at least twice in the semester (The dates will be finalized mutually agreed on).

3.4 Examination and Certificate:

Project Exhibition for evaluation of projects will be conducted after completion of the course delivery & project. Certificate will be provided by training agency & VIMEET to all participants. The evaluation scheme will be as follows:

- 20% Marks course learning
- 10% Marks Assignment and Attendance
- 50% Marks -Project





TRUE COPY

Page 3 of 8

3.5 Certificates and Awards:

Successful candidates will receive a "Course Completion Certificate" Signed by VIMEET & training agency. The Certificates will be issued by Training Agency.

Signature:

Principal, VIMEET, Khalapur.  Name: Dr. B. R. Patil Date: 10/06/2019	Authorized signatory of Training Agency  Name: Mr. Nimesh Baba Date: 10/06/2019
Witnesses	
1. Name: Mr. B. N. Pasi  Sign:	2. Name: Dr. Vikas V. Shinde  Sign:

TRUE COPY

Vikas V. Shinde
Principal (VIMEET)

Appendix I

PRE-REQUISITE

STUDENTS SHOULD HAVE KNOWLEDGE OF FOLLOWING TOPICS: -

Module	Topic
1	Introduction to Engines: Understanding the working of an Engine; Parts of an Engine and their materials; Classification of different types of Engines: 2-Stroke/4-Stroke, Diesel/Petrol/Hybrid. Hands on Different Engines.
2	Wheeler Engines Overhaul: Disassembly, Overhaul and Assembly of Two-wheeler Engines, Measurement of Engine Component Dimensions, Calculation of Gear Ratio, Swept Volume, Compression Ratio and other parameters, Valve Timing Diagram for 2-Stroke/4 Stroke Engine.
3	Valve Timing Diagram and Lubrication System: Valve Timing Diagram for 2-S/4-S Engine. Wet Sump Lubrication System, dry sump lubrication system, mist lubrication system
4	Material Selection and Design Aspect of IC Engine Material properties and their uses in design, Manufacturing consideration in design of IC engine components, Design of IC Engine Parts,
5	Transmission System: 1. Introduction: Need, Construction and Material. Working Types of transmission systems, merits and demerits. 2. Transmission System Overhaul: Complete Disassembly, Overhaul and Assembly of Semi-Automatic and Automatic Transmission System.

TRUE COPY

 Head of the Institute (IMEET)

Appendix II

Projects

S.No	Title
1.	CAD modelling of Piston cylinder assembly
2.	CAD modelling of Crank shaft assembly
3.	CAD modelling of Transmission System

APPROVED
BY
DATE: 08/08/2021

MEMORANDUM OF UNDERSTANDING FOR COOPERATION

This Memorandum of Understanding for Cooperation is entered into, and by and between

International Forum for Innovations in IP (IFFI),

Under endorsement

Repres. by **Prof. S. Inamdar**, **Chairman**

15, New V K, Kharipur, New Mumbai

India

And

Global Intellectual Standardization Forum for India (GISFI)

Represented by Prof. Ranveer Prasad, Chairman, GISFI

And

And

Repres. by Mr. Anil K. Gupta, Trustee

Survey No. 51, Kumbhdevi, Nr. Kharipur, Tq. Huka,

Dist. Mumbai Purv Expressway, Tq. Kharipur, Dist. Raigad, Maharashtra

India

And

Technical University of Sofia

Represented by **Rector Prof. Martin Hristov**

8, St. Kl. Ohridsky Blvd., 1000 Sofia, Bulgaria

20-10-11

TRU

20/10/11

PRE AMBLE

Whereas International Institute for Innovation in ICT (I4I) has been established for the purpose of advancing the Research, development and implementation of ICTs by the name that and work with the European Union, the projects and the next revolution in education and **IT Technology** - the industry, the government, the education, research and development.

Whereas I4I will be using the output of the Indian Institutes of Information Technology (IITs) skills in education, research and development and also making the best use of the present an opportunity to enter the technology world. This is to be an **ambition**.

Whereas Global ICT Standardization Forum for India, (GISFI), has been registered under society registration and Public Trust act in India and is an Indian non-profit organization body active in the area of information and communication technologies (ICT) and related application areas such energy, telemedicine, wireless, biotech, biomedicine and whereas GISFI addresses the research and product development of ICT in India and provides a bridge towards the globalization of the Indian education through the **Forum of Technology Governance and Development** and a platform for raising awareness of the importance and the internationalization of the higher education in the field are supported by the government of India.

Whereas Vishwaniketan is a research, development oriented, interdisciplinary group from industry, education and abroad groups. The members, experts of individuals, have started creating a world class computer based **Forum of Future - Global** expression and whereas Vishwaniketan will create a platform for students, teachers, researchers and professionals to adopt excellent teaching - learning, programs inspired by Project Based Learning, encourage entrepreneurship and family support product development through startups, and will empower teachers, business and the society by using technology solutions evolved and in doing so will promote value addition of self-learning and taking responsibilities and self-esteem in all stake holders and will create a **Global ICT India and GISFI** and is willing to create I4I in its campus.

Whereas Technical University of Sofia (TUS), established in 1947 is the leading Bulgarian engineering university with, at present, more than 800 researchers and lecturers, has strong international recognition and maintains intensive contacts with major European and US universities and founder of the Association for Business Cooperation linking International Relations departments of Higher Technical Schools from Central and Eastern Europe and a member of CRE (Conference of the European Universities' Rectors).

Now, therefore, the Parties have agreed to enter into cooperation as described in this MoU for Cooperation (hereinafter referred to as the 'Cooperation') - as follows.

1. The Payoffs

1.1.1

1.1.1.1. International Institute for Innovation in ICT (I²ICT) is established in order to carry out Research and Development activities in the Volkswagen Group's "Global Research and Development" (GRD) under the leadership of I²ICT will have initially seven research groups namely: Basic Information and Communications, Information Technology, Telehealth, Telemedicine, Cheminformatics, Mathematics and Technology Evolution & Applications, Basic Telecommunication and seven other sub-groups namely: Network and Security, Information and Communication (I²ICT), Radio Access Technology and Equipment, Software Defined Radio, Artificial Intelligence and Computer Engineering, Information Technology, and Physical Sciences. The Research areas / Fields of interest will be determined from time to time as per need of the user industry.

It is expected that the first areas to be added will be in the fields of Energy, Mechanical Engineering and Electrical Engineering.

I²ICT distinguishes itself from other Research and Development (R&D) initiatives by the expected impact of joint Indo-Danish program development of world leading technology solutions with the primary objective of advancing education by using the PBL model, commercialization of IPR and of research and techno-entrepreneurship promotion at the level of Masters and innovation at PhD level.

With I²ICT's application of PBL, the education system in India which is usually targeted toward achieving a job will move to the domain of innovative research leading to commercialization.

Innovative research projects are expected to lead to Intellectual Property Rights (IPR). I²ICT aims that the commercialization of the technology will give birth to the number of startup companies based on future technology leading towards the long term shift of R&D in India. I²ICT will have a holding company of its own which will provide self-sufficiency to the institute. All the startup companies will have shares in the institute's holding company; in turn the holding company will provide funding to the startups to carry out further basic research in thrust area of I²ICT.

I²ICT will work in the larger interest of complete world and specifically for improvement in Academic and Corporate life of India as a whole. I²ICT may be supported by the government of India, the government of Denmark, Aalborg University, European Commission and any other industry/institution who wish to contribute to the objectives of I²ICT.

1.1.2

1.1.2.1. Global Innovation Standardization Platform (GISP) will create a platform to facilitate discussion between bodies like major industrial countries or regions of the world and proactively interact in international forums such as, ITU, IEEE, ETSI, etc. GISP will be a platform for discussions on standardization of

to be a high quality and successful initiative, project partners will have to work together in a highly coordinated and transparent manner. This is not a new challenge for any of the partners.

1. To study the educational situation in India
2. To study the needs addressing the requirements of the Indian market
3. To study the existing support up infrastructure with in ICT and broader areas
4. To study existing disciplines by studying at the local universities
5. To study the existing situation for technical and power development in India for future development of power

VISHWANIKHAN

Vishwanikhan realizes that there is a definite need to modernize professional education in India to enable study to use mass power in industry to enhance innovation thinking by Indian entrepreneurs and to empower a growing community. It has strong belief that the education model of Technical University of Sofia has the potential to do this. It is developing 21 hours computer science from an international expert in Sofia, Bulgaria, where limited development in India is happening. A strong belief in following an fully computerized, ethical, and professional administration which will finally attract all the expertise from industry and academic circles to use the modernized professional education in any other figure. Mass based attraction of students, very vibrant teaching learning processes and industry friendly faculty will be the chief points of Vishwanikhan.

Technical University of Sofia.

Technical University - Sofia (TUS) established in 1925 is the leading Bulgarian engineering university with 27,000 students from 80 countries and institutes. TUS received the 1st prize competition in organizing research and teaching both at doctoral and Ph.D level. University research results have participated in more than 1000 international projects, and many national projects funded by the industry. TUS has strong governmental recognition and maintains intensive contacts with many European and US universities. TUS is the founder of the Association for Business Cooperation linking International Relations departments of Higher Technical Schools from Central and Eastern Europe and a member of ERU (a sub-group of the European Universities' Network). TUS staff has participated in many international scientific organizations, COMEA and UNESCO projects, joint projects under the TEMPUS, COMENIUS, COMPLUS, COST, FP5, FP6, FP7 and ERASMUS programmes with foreign partners from

20 countries in 16 countries. Centers of excellence in interdisciplinary research and training have been created at TU within several projects - national or international.

F. Organization

1. I will be established as an independent Research and Development center under Public Private Partnership (PPP) Model. ICT will work on the objectives initially as follows:-

1. To register at least 100 PhD students by the identified areas in engineering technology and other areas to conduct R & D with profitability to our industry

1. The "Center for IIT, Gandhinagar" will have the following objectives: promote research, disseminate knowledge by students, by IIT, and by the Technical University of Sofia, etc.

2. The center will have 100% share of the work to be done in the center and the staff will be employed exclusively all over the world.

3. The center will have 100% share in the following areas: a) to carry out the research required by students, b) and all other areas.

Regarding the center, the following provisions will be in force: a) the center will be established by the Government of India and will be a part of the Technical University of Sofia and will have the same legal status as the center in line with the provisions of the project proposal in cooperation with the Government of India for fulfillment of these objectives.

Following representative provisions will be placed in the Memorandum of Understanding already defined:

1. IIT/I, the partners in development of the center, will have the right of veto in all matters relating to the center and operations relating to the center and all other matters relating to the IACT.
2. The governing body of the IACT will be made up of the government of India, the center, operating through its representatives, shall state the terms and conditions relating to the center at the discretion of IIT/I.
3. The governing body will consist of eleven members of whom five shall be from the government, depending upon the provision of and investment of the government and IIT/I.
4. An organizational structure will be evolved as per existing IIT/I and IIT/I shall maintain research systems for the fulfillment of the vision of IIT/I.

The establishment and running of IACT will be absolute responsibility of the governing body of IACT.

4. Facilities

Vishwaniketan will make available 10 acres (42,000 sqm. less) of land to IIT/I. On the land, IACT will build a research facility in the manner as decided by the governing body.

The time duration for setting up the IACT is set to be 365 days and 12 hours so that will automatically return the required 10 acres (land) back to Vishwaniketan.

During the first phase of IACT defined in project proposal Vishwaniketan will provide research facilities of about 10,000 square feet to cover the need of research facilities the duration of which shall not exceed three years after the opening of IACT.

14.1 Education and research activities will start into the building as per a work plan. 14.1 management Vishwaniketan and (GSI) shall as stated below be solely and fully responsible for managing 100 maintaining the research facility. It includes the maintenance of the building, offices and laboratories and shall also cover all necessary cost for the facility.

5. Responsibilities of IAC T

In addition to the responsibilities mentioned under Articles 3 & 4 above IAC T shall be responsible for the following:

IAC T will conduct Masters and PhD programs in collaboration with Technical University of Sofia, (TSEI) and other universities industrial partners in accordance with the law and regulations applicable for the Schools and Doctoral School of Technical University of Sofia.

IAC T will introduce and conduct a "Life Fellowship" programme for and to Indians with universities abroad, for 45 days training on projects, PhD, specific courses and research advancements or special learning on topics of common interest.

IAC T will conduct undergraduate programs in cooperation with Vishwaniketan and TSEI Technical University of Sofia providing always that the relevant and necessary approvals and permissions are granted under national legislation of the countries involved.

Up to 100 PhD/post graduate candidates will be registered per year under the supervision of competent professors and practitioners from Government India.

Annually IAC T will provide its expertise to all stake holders for exploring possibilities of their expansion in the huge market of India in education, equitably within the legal boundary of Indian Judiciary System.

6. Responsibilities of GSI/CTIF India

In addition to the responsibilities mentioned under Articles 3 & 4 above, GSI shall be responsible for the following:

GSI will develop and control the vision, activities and functioning style and all other operative matters for IAC T jointly with other stake holders and partners.

GSI and the partners involved with CTIF India will be responsible also to create the laboratories, other academic infrastructure by way of raising funds through investments partners/industries/funding agencies etc. GSI also will be responsible to involve its members in development of IAC T especially the industry members to create research laboratories, allocate projects to faculty and students of Vishwaniketan by sharing standardization process, seminars, etc.

concluded that the cooperation should be initiated. The cooperation will be initiated by the Board of the Technical University of Sofia, Bulgaria, and the Board of the Vishwavidyalaya, India. The cooperation will be initiated on the basis of the Agreement signed between the two countries in 1997 related to the cooperation.

7. Responsibilities of Vishwavidyalaya

In addition to the cooperation under the present Agreement, the Board of the Vishwavidyalaya will be responsible to provide the following facilities to the students of IIT:

Vishwavidyalaya will, if necessary, provide immediate arrangements for the admission of all visit students, PhD students and IIT faculty members. The cost of the visit will be borne

The obligations for the hostel facilities will be according to the conditions of the Vishwavidyalaya for other students staying in the campus. The staff quarters will also be made available to employees, faculty, PhD students, postgraduate and postgraduate students of the IIT on rent decided upon the prevailing market rates depending upon availability. All the contractual facilities such as parking, electricity, telephone, water supply, parking etc. will be made available to IIT faculty members and staff members on a par with existing norms.

In addition, Vishwavidyalaya will offer teaching assignments to the faculty of IIT and students of IIT on remuneration (with Scholarship) based on existing practice of Vishwavidyalaya. The eligible faculty of Vishwavidyalaya may be invited to participate in research activities of IIT on remuneration to be decided on pre-arrangement.

Furthermore, Vishwavidyalaya will admit to all IIT students of minimum the academic quality of interested IIT faculty for the CTIL (CSRI) - Computer Network amongst around 3500 Engineering colleges in India. The IIT faculty and executives may offer its services as supervisors of such south Asia. Vishwavidyalaya will invite Technical University of Sofia to cooperate in this initiative on mutually agreed terms and conditions.

8. Responsibilities of Technical University of Sofia

Whenever the Technical University of Sofia enters into cooperation with partners in India regarding the education of PhD, MS and undergraduate students, the general principles for this cooperation will be added as Appendix to this MoU. This general principle will be replaced by a more detailed agreement to be entered into by Technical University of Sofia and Vishwavidyalaya.

Technical University of Sofia shall provide information regarding existing PhD programs available under the Doctoral Schools of Technical University of Sofia. Technical University of Sofia will provide sufficient information regarding

Technical University of Sofia

Technical University of Sofia
Faculty of Mechanical Engineering
Bulgarian Academy of Sciences
Technical University of Sofia
Bulgarian Academy of Sciences

To ensure the success of the project, the Technical University of Sofia agrees that Administrative staff as well as eligible students of Technical University of Sofia will ensure accepting classes supplemented by lectures and written reports prepared by the staff representing the relevant Technical School.

The PhD applicant shall be considered to be a student of the Technical University of Sofia.

Technical University of Sofia will, in cooperation with the Indian partner, achieve financial funding for your research, purchase of scientific equipment, establishment of laboratories (BCT) with funding from the Indian partner, etc. in its professional areas. (BCT)

Technical University of Sofia wishes to sign the MoU and hereby requests you to put the signing of this MoU, if you are willing, the presence of the representatives of Bulgarian and Indian legislation.

Technical University of Sofia will consider offering 45 days training program for students / courses / projects to be developed jointly by the members of the Joint Network in India. This activity is expected to increase the interest of the students to join Technical University of Sofia MS Programme in a later stage. Technical University of Sofia is also expected to proactively engage into sharing time lectures / conferences conducted at Technical University of Sofia through video conferencing. Technical University of Sofia will provide faculty for 40 days of time sharing of faculty and students of BCT, at Technical University of Sofia campus will also give full access to the laboratories and library for the students and faculty of BCT. Further details, such as methodology, fee structure, etc. will be agreed by the involved Parties and shall be included in a separate annex to this Cooperation Agreement.

A Principle of 85% Tuition waiver will be considered for all such fellowships, a proactive approval will be taken by Technical University of Sofia to increase interest of Indian Students in all such fellowships.

For IIT J

Place _____

For Technical University of Sofia

Place _____

Dr. N. S. Bhatnagar
Secretary, AICTE, New Delhi

Prof. Dr. V. V. Korotkiy
Rector, Technical University of Sofia

For GEFU
Place and date

Rajiv

Prof. Paritosh Prasad
Chairman, GEFU

Mr. G. H. ...
Rector

Prof. Vishwanandan
Place and date

Mr. Anil K. Gupta
Trustee, Vishwanandan,
Chairman, HMRITM

Anil Kumar Gupta

TRUE COPY

[Signature]
Vishwanandan (HMRITM)

COOPERATION AGREEMENT

For I-G Fellowship

This Agreement is being signed by the undersigned on the following dates:

At **Mumbai**

Represented by **Prof. P. S. Joshi**

Address No. 1, Road No. 16, Chhatrapati Shivaji Maharaj Vastu Sangrahalaya

Dr. Mughan Prasad (Prof. & Head) K. J. Somaiya Institute of Management Studies and Research,
Gulf Road

And

Interdepartmental Center (IIC) **University of Rome Tor Vergata**

(hereafter called CUIF-Italy)

Represented by **Prof. Alessandra Colotta**

Via del palatino 1,

00133 Rome

PREAMBLE

Whereas **Vishwanikatan** is a registered trust/society formed by professionals drawn from industry, education and administration with excellent experience of individuals, has started creating a world class campus near Navi - Mumbai on Pune - Mumbai express-way and whereas **Vishwanikatan** will create a platform for students, teachers, researchers and professionals to adopt excellent teaching - learning practices inspired by Project Based Learning, encourage entrepreneurship and finally support product development through startups, and will empower teachers, business and the society by using technology solutions provided and to *do good*, so will promote values, ability of self-learning and taking responsibility and self-esteem in all stakeholders.

Vishwanikatan realizes that there is an acute need to transform professional education in India to create ready to use *high power* for industry, to inculcate innovative thinking in student community and to empower teaching community. It has strong belief that the education model of University of Rome Tor Vergata has the potential to do this.

CUIF-Italy is an Interdepartmental Center of the University of Rome Tor Vergata (CUIF-Italy is also known as the Center of Rome Tor Vergata (Italian) Università degli Studi di Roma Tor Vergata)



COPY

[Signature]
Prof. P. S. Joshi

Cooperation Framework Agreement

December 19, 2017

1. **Parties:** The Ministry of Education, Youth and Sports of the Republic of Turkey and the Ministry of Education, Youth and Sports of the Republic of Azerbaijan

2. **Subject:** The purpose of this Agreement is to establish a framework for cooperation between the Ministry of Education, Youth and Sports of the Republic of Turkey and the Ministry of Education, Youth and Sports of the Republic of Azerbaijan in the field of education, youth and sports.

3. **Objectives:** The objectives of this Agreement are to promote cooperation between the Ministry of Education, Youth and Sports of the Republic of Turkey and the Ministry of Education, Youth and Sports of the Republic of Azerbaijan in the field of education, youth and sports.

4. **Principles:** The principles of this Agreement are to promote cooperation between the Ministry of Education, Youth and Sports of the Republic of Turkey and the Ministry of Education, Youth and Sports of the Republic of Azerbaijan in the field of education, youth and sports.

Receiving

Ministry of Education, Youth and Sports of the Republic of Turkey

Pursuant to

Observance of the national legislation concerning the field of the Parties and cooperation under the present program.

Leading to

Successful implementation of educational cooperation between the Ministry of Education, Youth and Sports of the Republic of Turkey and the Ministry of Education, Youth and Sports of the Republic of Azerbaijan.

1. Subject

1.1. For cooperation implementation and carrying out objectives of scientific and educational projects of the Parties, the Parties shall carry out following kinds of cooperation:

Educational activities

Exchange by educational and study groups including staff exchange

Exchange by experience and information concerning educational practice and pedagogical support

Joint development and preparation and publication of educational and study guides including with copies taking into account observance of intellectual property rights of authors and both Parties

- Carrying out of framework and development of distance educational technologies,
- Carrying out of joint research and methodology conferences and international symposiums,
- Organization of both Parties' teachers professional skills development by mutual training,
- Both Parties' teachers exchange for lecturing on the theme coordinated by the Parties,
- All types of academic mobility, students' reciprocal exchange
- Cooperation in the framework of joint educational projects,
- Implementation of joint bi-annual programs

Azerbaijan will start sending three groups of students for summer training, organization of electronic and analogical departments totaling approximately 70 students for the first training starting in June 2017.

Research activities:

Joint carrying out of researches, sharing of achieved results, publications of articles in scientific journals and mutual collections of scientific works.

- Mutual special purpose exchange of post-graduate and doctoral students of the Parties
- Organization of mutual training of scientific, pedagogical and administrative staff of the Parties
- Joint implementation of the projects being a part of joint scientific and technical international programs.

Joint organization of international research and joint conferences.

Providing of conditions for use of scientific equipment and student's community of facilities and resources as well as equipment of the Parties in carrying out of scientific researches.

TRUE COPY
[Signature]
[Stamp]

1. Name of the Project

1.1. Project Name: *Project Name*

1.2. Project Number: *Project Number*

1.3. Date:

1.4. Location: *Location*

1.5. Duration: *Duration*

1.6. Budget: *Budget*

1.7. Lead Institution: *Lead Institution*

2. Objectives of the Project

- 2.1. The Project shall have the following objectives: *Objectives*
- 2.2. The Project shall have the following specific objectives: *Specific Objectives*
- 2.3. The Project shall have the following deliverables: *Deliverables*

3. Roles and Responsibilities

- 3.1. The *Lead Institution* shall coordinate the project and ensure that all objectives are met.
- 3.2. All activities shall apply to the *Project*.
- 3.3. The *Project* shall have the following roles and responsibilities: *Roles and Responsibilities*
- 3.4. The *Project* shall be subject to external review and evaluation, including *External Review*.
- 3.5. Agreement is made in Hindi in English and *Other Languages*.
- 3.6. All parties have equal legal power for such of the *Project*.
- 3.7. Upon the execution of this agreement, the *Project* shall be subject to all national laws, *National Laws*.

3.8. The *Project* shall have the following specific objectives: *Specific Objectives*

3.9. The *Project* shall have the following deliverables: *Deliverables*

3.10. The *Project* shall be subject to external review and evaluation, including *External Review*

Details and Signatures of the Parties

**Sanskrit Technical University of Education
"Igor Sikorsky Kyiv Polytechnical Institute"**

1. Name of the Party: *Name*

2. Address: *Address*

3. Contact Person: *Contact Person*



Vishva Vidyapeetham

Managing Trustee / Secretary

Name **Prof. Sandeep Inamdar**
Legal Address: *Address*, No. *Number*, *City*, *State*, *India*



TRUE COPY
Signature

1. **Умови проведення конкурсних процедур**
1.1. Конкурсні процедури будуть проводитися в електронній формі за допомогою системи електронного управління закупівлями (СЕЗ) на веб-сайті: www.zakup.gov.ua.
1.2. Умови проведення конкурсних процедур будуть визначені в умовах проведення конкурсних процедур, які будуть розміщені на веб-сайті: www.zakup.gov.ua.

2. **Умови участі в конкурсах**

2.1. Умови участі в конкурсах будуть визначені в умовах проведення конкурсних процедур, які будуть розміщені на веб-сайті: www.zakup.gov.ua.

3. **Інші умови участі**

3.1. Умови участі в конкурсах будуть визначені в умовах проведення конкурсних процедур, які будуть розміщені на веб-сайті: www.zakup.gov.ua.

3.2. Умови участі в конкурсах будуть визначені в умовах проведення конкурсних процедур, які будуть розміщені на веб-сайті: www.zakup.gov.ua.

3.3. Умови участі в конкурсах будуть визначені в умовах проведення конкурсних процедур, які будуть розміщені на веб-сайті: www.zakup.gov.ua.

3.4. Умови участі в конкурсах будуть визначені в умовах проведення конкурсних процедур, які будуть розміщені на веб-сайті: www.zakup.gov.ua.

3.5. Умови участі в конкурсах будуть визначені в умовах проведення конкурсних процедур, які будуть розміщені на веб-сайті: www.zakup.gov.ua.

Результатів та підписи Сторін

Національний державний університет
«Київський національний університет
імені Шевченка»

Ushwanketaw

Перший підписувач

Другий підписувач

Власник
Університету
Президент



Власник
Університету
Президент





Apr 02, 2018

Dear Mr. Arnav Mahajan:

I am pleased to offer you an internship in the Stevens Institute for Artificial Intelligence at SIT. The anticipated timeframe of your visit is starting 18th June, 2018 and ending 26th July, 2018.

As part of this internship, you will be engaged in developing technical projects in the area of Artificial Intelligence (AI). You will, in specific, research AI applications, algorithms and implementations.

During your time at Stevens, you will be under the supervision of Director Koduvayur P. Subbalakshmi and Professor Jose Ramirez-Marquez. You will be required to comply with all Institute policies and procedures, which are subject to change from time to time.

Please indicate your acceptance of this offer by signing.

Sincerely,

Prof. Koduvayur P. Subbalakshmi, Ph.D.
Director, Stevens Institute for Artificial Intelligence

I wish to work under the guidance of
DR. Kishore Pochiraju in the field of mechatronics
engineering

Name arnav mahajan

Date 11th April 2018

TRUE COPY

Vishwanathan, Ph.D.

1. Definitions

- A. "Party" means...
- B. "Agreement" means...

2. Purpose

The purpose of this Agreement is to...

3. Terms

The term "Agreement" shall refer to the entire...

4. Termination

This Agreement shall remain in effect until...

The parties agree that the Agreement shall...

"Third Party" is a party to the Agreement...

"Third Party" is a party to the Agreement...

5. Final Provisions

This Agreement shall take effect on the...

This Agreement may be substantively amended...

1. Title

This Agreement shall be known as...

2. Parties

The parties to this Agreement are...

The parties hereby acknowledge that...

3. Purpose

The purpose of this Agreement is to...

The parties agree that the Agreement shall...

"Third Party" is a party to the Agreement...

"Third Party" is a party to the Agreement...

4. Final Provisions

This Agreement shall take effect on the...

This Agreement may be substantively amended...

TRUE COPY
[Signature]
[Name] (PRINT)

Article 10. Exchange of Information

10.1. The two parties shall exchange information on their activities in the field of research and development.

10.2. Technical Information

10.2.1. Each party shall retain the right to use its own proprietary information, patents, and know-how.

10.2.2. The purpose of this article is to ensure that confidential information is not disclosed to the other party.

10.3. Student Exchanges

10.3.1. A number of students from each university shall study at the other university for a limited number of semesters.

10.3.2. Each and every student shall meet the following conditions:

10.3.2.1. If applicable to the Home Institution, institutional criteria set by the Host Institution shall be observed, such as the Home Institution's and the Home University's policies.

10.3.2.2. If the Host Institution allows, then the participants in the program shall be:

10.3.2.3. The tuition, fees, and other applicable charges shall be the responsibility of the student who is attending the Host Institution.

10.3.2.4. Host Institutions will charge Home Institution students the applicable tuition and other charges, and will help locate housing and provide other assistance to the visiting students.

10.4. Joint Research Projects

10.4.1. In the event a joint research project is proposed by either party, such research effort shall be carefully scrutinized by both parties to evaluate the need for the joint effort, the qualifications of the proposed participating faculty members, and the location of the research activity. If a decision is made by both parties herein to approve the proposed project as a worthwhile joint effort, both institutions agree to actively seek outside funding for the proposed joint research project prior to their final approval and implementation of the joint project.

10.4.2. In any joint project between the two institutions, care shall be taken to ensure that

TRUE COPY

to the people and our

to the people and our

to the people and our

to the people and our

to the people and our

to the people and our

to the people and our

to the people and our

to the people and our

to the people and our

to the people and our

to the people and our

to the people and our

to the people and our

to the people and our

to the people and our

to the people and our

to the people and our

to the people and our

to the people and our

to the people and our

to the people and our

to the people and our

to the people and our

to the people and our

to the people and our

to the people and our

to the people and our

to the people and our

to the people and our

to the people and our

to the people and our

to the people and our

to the people and our

to the people and our

to the people and our

to the people and our

to the people and our

to the people and our

to the people and our

to the people and our

to the people and our

to the people and our

to the people and our

to the people and our

to the people and our

to the people and our

to the people and our

to the people and our

to the people and our

to the people and our

to the people and our

to the people and our

to the people and our

to the people and our

to the people and our

to the people and our

to the people and our

14.1 Entire Agreement
This Agreement, together with the Exhibits attached hereto, constitute the entire agreement between the parties with respect to the subject matter hereof.

14.2 Amendment

This Agreement may be amended or modified only by a written instrument signed by both parties.

14.3 Assignment

This Agreement may not be assigned, in whole or in part, without the prior written consent of the other party, which consent shall not be unreasonably withheld.

14.4 Counterparts

This Agreement may be executed in counterparts, each of which when taken together shall be deemed to constitute one and the same agreement. Each counterpart shall be deemed to be an original copy of this Agreement, and all such counterparts together shall constitute one and the same agreement.

14.5 Severability and Survival of Provisions

Should any provision of this Agreement be held to be unenforceable, the remainder of this Agreement shall nevertheless remain in full force and effect. The provisions of this Agreement shall survive the termination or expiration of this Agreement.

14.6 Governing Law

This Agreement shall be governed by and construed under the laws of the State of Arizona, which shall be the forum for any and all disputes hereunder.

14.7 Waiver

A waiver of any breach of any provision of this Agreement shall not be construed to be a continuing waiver of said breach or a waiver of any other breaches of the same or other provisions of this Agreement.

14.8 Notwithstanding

This Agreement may not be amended by either party without the advance written consent of the other. This Agreement shall be binding upon the parties, their heirs, assigns, successors and

beneficiaries, and shall be enforceable against the parties, their heirs, assigns, successors and beneficiaries, and shall survive the termination or expiration of this Agreement.

IN WITNESS WHEREOF, the parties have hereunto set their hands and seals, and have signed the foregoing instrument, this 14th day of August, 2014.

and to the true contents of certain executed instrument.

and to the true contents of certain executed instrument.

and to the true contents of certain executed instrument.

and to the true contents of certain executed instrument.

and to the true contents of certain executed instrument.

and to the true contents of certain executed instrument.

and to the true contents of certain executed instrument.

and to the true contents of certain executed instrument.

and to the true contents of certain executed instrument.

and to the true contents of certain executed instrument.

and to the true contents of certain executed instrument.

TRUE COPY
[Signature]

State of _____
County of _____

To Have and to Hold unto the
University of Utah and its Board of
Trustees for the use and benefit of
The Children's Hospital and
Child Health Research Center
Little Rock, Arkansas

The Managers of the
University of
Utah and its Board of Trustees
of Little Rock, Arkansas

do hereby certify and warrant as being the true and correct copy of the
agreement and instrument by the above parties

IN WITNESS WHEREOF, the parties and Agreement have caused this
True Copy of this Agreement to be signed by _____

INSITITUTION

(PRINTED NAME)

Board of Trustees of the University of
Arkansas acting for and on behalf of the
University of Arkansas at Little Rock

Managing Trustee of
University of Arkansas at Little Rock

By _____
(Signature)
Bruce McCaffery
(Printed Name)

By _____
(Signature)
Dr. Nandeep S. Jandora
(Printed Name)
Managing Trustee of Vahvanikatanu
(Title)

Miss Chandra Das for Finance and Admin. Purposes
(Title)

Witness my hand and
the Seal here of _____
this _____ day of _____

TRUE COPY

WIT



ITU

International Technological University
11025 N. De Anza Blvd., Suite 100
San Jose, CA 95128
Tel: 408.434.2000
www.itu.edu

AGREEMENT FOR SUMMER PROGRAM Between

International Technological University Foundation, Inc.

And

Vishwaniketan Institute of Management, Entrepreneurship and Engineering Technology

This Agreement is entered into by and between International Technological University Foundation, Inc. (ITU), with its principal address at 2711 North First Street, San Jose, California 95134-USA, and Vishwaniketan Institute of Management, Entrepreneurship and Engineering Technology (Vishwaniketan), with its principal address at Unit No. 52, Off Mumbai Pune Expressway, Kumbhwar, Tal. Khairatpur Maharashtra 410200.

OBJECTIVE OF AGREEMENT

The purpose of this agreement is to specify the terms and conditions for ITU to provide a summer program for Vishwaniketan IR-Fellowship students and faculty of the ITU campus located in San Jose, CA.

ABOUT ITU

Established in 1994 by Dr. Sha-Park Chan, ITU provides excellence in education for the future leaders of Silicon Valley corporations. Utilizing the best of Silicon Valley's technology and business models to advance developing economies throughout the world, ITU reflects and enhances Silicon Valley's unique business culture with six industry-oriented departments that provide high-quality academic and practical training and offer unparalleled educational programs in electrical engineering, digital logic, computer science, computer engineering, software engineering, engineering management, and business administration.

ABOUT VISHWANIKETAN

Vishwaniketan is a registered trust/society under Indian law, initiated by professionals drawn from industry, education, and administration with extensive experience. With a world class campus near Navi-Mumbai on Pune-Mumbai expressway, Vishwaniketan created a platform for students, teachers, researchers, and professionals to adopt excellent teaching, learning practices inspired by Project Based Learning, encourage entrepreneurship, and support product development through student parity with partners abroad. Its programs empower teachers, businesses, and society by using technological solutions to promote positive values, ability of self-learning, taking responsibility, and building self-esteem. In the past, Vishwaniketan has hosted CDD (India and GISF).

Global Development Through Silicon Valley Education



TRUE COPY

Faculty Advisor Responsibilities

Faculty Responsibilities

- Provide your written approval to the program by May 15, 2018
- Provide approval for the use of the student's name
- Have adequate knowledge to answer questions regarding the program
- Provide information to assist in the development of the program
- Provide quality of instruction to the student's learning experience

Student/Student & Responsibilities

- Complete and submit required paperwork provided regarding participation in the program as required
- Meet participation criteria of the program (GPA, Financial Aid, etc.)
- Make participants aware of the responsibilities and expectations associated with the program
- Arrange international travel for participants
- Arrange lodging for students and provide accommodations
- Develop pre-arrival guide prepared by faculty participants
- Attend a faculty meeting to discuss the standards of the program
- Pay the program fee of \$10,000 per student date by 5/15/2018

PROGRAM DATE

Date: June 18, 2018 through ending July 30, 2018

NUMBER OF PARTICIPANTS 10 students and 1 faculty member as per the agreement (Appendix)

CANCELLATION

A full refund will be made upon receiving proof of visa cancellation by May 17, 2018 around a participant's visa application is denied.

CONFIDENTIALITY

Each party shall keep confidential all information provided by the other party in relation to this program and shall not, without prior written consent, use or discuss or otherwise make available this information to any party to any person except to use the materials for authorized promotional purposes to prospective students, faculty and staff. This provision shall survive the termination of this Agreement.

[Signature Page Follows]

TRUE COPY

Signature
Vandana Kanna's (MNET)

AGREED AND AFFIRMED BY

International Technological University
Foundation, Inc.
Gregory M. Bl L. D'Brin, Ph.D.
President and CEO

Vishwakarma's Institute of Management
Entrepreneurship and Engineering Technology
Dr. Sandeep S. Jangdar
Vice President

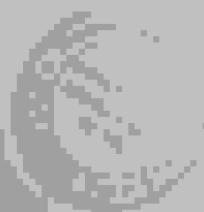

Page 3 of 4

TRUE COPY
Sandeep S. Jangdar
Vishwakarma's Institute of Management



MEMORANDUM OF UNDERSTANDING

Between Teesside University of Middlesbrough (TU), USA and Alhambraikan, Gateway No-50 Off Mainroad, Puzos, Middle Malabar District, Kerala (The Parties)

Dated this Memorandum is to take effect

1. This Memorandum of Understanding, jointly, MOU, recognises the intention of the Parties to establish and build a relationship co-operative in a broad range of areas and to work together to gain a mutual benefit. The Parties may seek to encourage and develop collaborative activities in various ways, including but not limited to, the exchange of scholarly ideas/experience and research, the support of specific discipline interaction, the development of programmes, student exchanges, and advance entry from one institution to the other where the students are appropriately qualified.
2. Separately agreements will be required for any definitive collaborations as articulated by the Teesside University's quality processes. The Parties understand that any financial considerations associated with any collaboration will be dealt with via a legally binding contract. In the course of discussions the Parties may, before the entering of a legally binding contract wish to document the understanding reached on financials. In such cases, the Parties agree to append any such understanding to this MOU in Appendix A.
3. Both Parties recognise the value of this MOU in promoting its own programme and activities. However, any marketing material/activity which includes reference to the other party must be sent to that Party and be approved before use.
4. This MOU is for 3 years in the first instance and will be reviewed thereafter. Each Party has the right to discontinue the arrangements subject to a period of 3 months' notice to be given. This MOU may also be terminated at any time by mutual consent of both Parties.
5. In the event of termination, the Parties will honour any agreed commitments either via existing agreed arrangements or by suitable negotiated alternatives.
6. This MOU signifies a statement of intention to collaborate but is not a legally binding document and has no legal effect. The Parties agree that neither Party will make a claim against the other for any loss or damage (including but not limited to any consequential damages or lost profits arising from any disclosure, actions taken in reliance on the MOU or for termination of the negotiations) without reaching a comprehensive agreement.

Signatures to the Agreement

D. B. Bell

Dr David Bell
Pro Vice-Chancellor International

13/2/18

Dr S Inamdar
Vice-President

For and on behalf of Teesside University For and on behalf of Alhambraikan

TRUE COPY

TRUE COPY

MEMORANDUM OF UNDERSTANDING FOR COOPERATION

This Memorandum of Understanding for cooperation is signed by the following:

International Institute for Tropical Agriculture (IITA)
IITA, Ibadan, Oyo State, Nigeria

Represented by **Prof. S. S. Isomidehin**, **Director General, IITA**

Head, Centre for Horticulture, Naya Mandir

India

And

Global ICT Standardization Forum for India (GSFI)

Represented by **Prof. Ramesh Prasad**, Chairman, GSFI

And

Arbhavbhatta

Represented by **Mr. Anil K. Gupta**, Trustee

Survey No. 52, Kumbhwar, Nr. Khatap, Tal. Naha.

Dist. Mandla, Panch. Prasa, Tal. Khatap, Dist. Raigarh, Madhya Pradesh

India

And

Technical University of Sofia

Represented by **Rectar Prof. Maria Hristova**

8, 50 Kh. Ouhinsky Blvd., 1000 Sofia, Bulgaria

PREAMBLE

Whereas **International Institutes for Information Technology (IIT)** is established for the purpose of providing world-class education and training in the field of Information Technology, aimed primarily to meet the growing needs of India in the global field of work with the Europe in view of the partnership of the next revolution in science and technology; for the development of the country in the education, research and the socio-economic;

Whereas **IIT** will combine the best of the Indian Energy and highest technological skills in education, research and entrepreneurship and will undergo a global partnership opportunity to enter into the global market India for mutual benefit;

Whereas **Global ICT Standardization Forum for India (GISFI)** is a society, incorporated under society registration and Public Trust act in India and is an Indian standardization body active in the area of information and communication technologies, ICT and related application areas, such energy, telemedicine, single coordination, biotechnology and whereas GISFI addresses the research and product development of ICT in India and provides a bridge towards the globalization of the Indian achievements in the field of Technology, Convergence and Development and a platform for raising awareness of the importance and the internationalization of the higher education in the field are supported by the government of India;

Whereas **Vishwaniketan** is a registered trust society of trained IT professionals, trained from industry, education and administration with excellent experience in industry. It started creating a world class campus near New Mumbai on Powai Mumbai expressway and whereas Vishwaniketan will create a platform for students, teachers, researchers and professionals to adopt excellent teaching - learning practices inspired by Project Based Learning, encourage entrepreneurship and finally support product development through startups, and will empower teachers, business and the society by using technology solutions evolved and in doing so will promote value, ability of self-learning and taking responsibilities and self-esteem of all stake holders and therefore has hosted CTIP India and GISFI and is willing to create IIT in its campus;

Whereas **Technical University of Sofia (TUS)**, established in 1945 is the leading Bulgarian engineering university with at present more than 800 researchers and lecturers, has strong international recognition and maintains intensive contacts with major European and US universities and founder of the Association for Business Cooperation linking International Relations departments of Higher Technical Schools from Central and Eastern Europe and a member of CRE (Conference of the European Universities Review)

Now, therefore, the Parties have agreed to enter into cooperation as described in this **MoU for Cooperation** (hereinafter referred to as the "Cooperation") - as follows:

16.1 The International Institute for Economic Research and Development (IIE) is a non-profit organization that has been established since the late 1950s. It is a global organization that has been established in the United States, Canada, and other countries. The IIE is a non-profit organization that has been established since the late 1950s. It is a global organization that has been established in the United States, Canada, and other countries. The IIE is a non-profit organization that has been established since the late 1950s. It is a global organization that has been established in the United States, Canada, and other countries.

It is suggested that the main purpose of the IIE is to provide information and research on the economic and social conditions of the world.

The IIE is a non-profit organization that has been established since the late 1950s. It is a global organization that has been established in the United States, Canada, and other countries. The IIE is a non-profit organization that has been established since the late 1950s. It is a global organization that has been established in the United States, Canada, and other countries.

With IIE's appointment of IIE, the IIE is a non-profit organization that has been established since the late 1950s. It is a global organization that has been established in the United States, Canada, and other countries.

In addition, the IIE is a non-profit organization that has been established since the late 1950s. It is a global organization that has been established in the United States, Canada, and other countries. The IIE is a non-profit organization that has been established since the late 1950s. It is a global organization that has been established in the United States, Canada, and other countries.

The IIE is a non-profit organization that has been established since the late 1950s. It is a global organization that has been established in the United States, Canada, and other countries. The IIE is a non-profit organization that has been established since the late 1950s. It is a global organization that has been established in the United States, Canada, and other countries.

6.1.1 The IIE is a non-profit organization that has been established since the late 1950s. It is a global organization that has been established in the United States, Canada, and other countries. The IIE is a non-profit organization that has been established since the late 1950s. It is a global organization that has been established in the United States, Canada, and other countries.

business projects, and services for the benefit of the community and the development of the region. The IACT will be a joint venture of the following:

- Technical University of Sofia (TUS) – Bulgaria
- Indian Institute of Technology (IIT) – India
- Technical University of Varna (TVU) – Bulgaria
- Technical University of Sofia (TUS) – Bulgaria
- Technical University of Sofia (TUS) – Bulgaria
- Technical University of Sofia (TUS) – Bulgaria
- Technical University of Sofia (TUS) – Bulgaria
- Technical University of Sofia (TUS) – Bulgaria
- Technical University of Sofia (TUS) – Bulgaria
- Technical University of Sofia (TUS) – Bulgaria

VISHWANIKETAN

Vishwaniketan may provide that IIT will be an academic need to familiarize professional students in India to create ready to use, ready power for industry. Its incubate innovative thinking in student community and to encourage teaching community. It has strong belief that the education model of Technical University of Sofia has the potential to do this. It is developing 21 acres campus very close to an operational airport in New Mumbai, where fastest development in India is happening. Vishwaniketan believes in fully integrated, ethical, and professional administration which will finally gather all the expertise from industry and academic systems of to use the state-of-art in Indian education to meet global future. Merit based selection of students, very vibrant teaching (learning process) and industry friendly faculty will be the silent partner in Vishwaniketan.

Technical University of Sofia

Technical University – Sofia (TUS), established in 1948, is the leading Bulgarian engineering university with at present more than 800 researchers and lecturers. TUS proved that it is very competitive in engineering research and teaching both at national and EU level. University research teams have participated in more than 2000 international projects, and many national projects funded by the industry. TUS has strong international recognition and maintains intensive contacts with major European and US universities. TUS is the founder of the Association for Business Cooperation linking International Relations departments of Higher Technical Schools from Central and Eastern Europe and a member of CRT (Conference of the European Universities Rectors). TUS staff has participated in many international scientific organizations, COMEA and UNIDO projects, joint projects under the TEMPUS, COOPERATION, COMECON, COST, EPS, EP6, FP7 and ERASMUS programmes with foreign partners from 28 universities in 16 countries. Centers of excellence or interdisciplinary research and training labs were created at TU within several projects – national or international.

3. Organization

IACT will be established as an independent Research and Development center under Public-Private Partnership (PPP) Model. IACT will work on the objectives initially as follows:

- 1) To register at least 100 PhD students in the identified areas in engineering technology and other areas and conduct research useful/valuable to user industry.

Technical University of Sofia, Faculty of
Mechanical Engineering &
University of Sofia.

Prof. Dr. Kiril Kirilov, 2004-2008 and as
Associate Professor, Faculty of Mechanical Engineering of

Technical University of Sofia, Faculty of
Mechanical Engineering & Technical
University of Sofia, Faculty of Mechanical
Engineering.

4. The following are the objectives of the proposed research system as well as being in
the overall technical and industrial sphere:

Regarding IACT, the role of the national partners (GSIPL, Vishwavidyalaya, Ashbury
University, Technical University of Sofia and the industry partners) will be focused
in line with the principal objective of the research system in the framework they are doing
for fulfillment of these objectives.

Following organization structure will be developed in accordance of the goals and the
objectives already defined:

1. GSIPL, the partners involved in the IACT national organizations will develop and
control the value added research, development and production of their respective nations for
IACT.
2. The governing body of the IACT will be made the governing body of 11 members
including apparatuses and agencies of all states involved partners, which will be
organized in the form of a committee.
3. The governing body of IACT will always have to be in decided by a time to
time, depending upon the activities and research results by the nation partners
and multinationally.
4. An organizational structure will be developed to provide a system which would share
national research resources and the national of the members of IACT.

The establishment and starting of IACT will be ultimate responsibility of the governing
body of IACT.

4. Facilities

Vishwavidyalaya will make available 10 acres (42000 sqm, Sq feet) land for IACT. In this
land, IACT will build a research facility in the domain as decided by the governing body.

The time duration for setting up the IACT is not to be 3 years and failure to this will
be mutually return the required 10 acres land back to Vishwavidyalaya.

During the first phase of IACT defined in project proposal Vishwavidyalaya will provide
research facilities of about 10,000 square feet to cover the need of research facilities the
duration of 3 years shall not exceed three years after the opening of IACT.

ICTI education and research projects will fall into the latter category provided in phase 1 of ICTI management. Vigneshwaran and IISIT shall as stated above be solely and fully responsible for managing and running of the research lab. The remainder (in the maintenance of the building, office and laboratories and other equipment and all running cost) by the faculty.

5. Responsibilities of ICTI

In addition to the responsibilities mentioned under Article 3 & 4 above, ICTI shall be responsible for the following:

ICTI will conduct Masters and PhD programs in collaboration with **Technical University of Sofia, CISI** and other universities abroad in accordance with the law and regulations applicable to the Schools and Doctoral Schools of **Technical University of Sofia**.

ICTI will introduce and conduct 3 to 6 month program for students with universities abroad for 45 days training on projects, PhD courses for research and recent advancement or special learning on topics of common interest.

ICTI will conduct undergraduate programs in cooperation with **Vishva Vidyapeeth and AAU, Technical University of Sofia** providing always that the selection and necessary approvals and permissions are granted under national regulations of the countries involved.

Up to 100 PhD post graduate candidates will be recruited per year under the supervision of competent professors and practitioners from Europe and India.

Faculty ICTI will provide its expertise to all stakeholders for exploring possibilities of their expansion in the huge market of India in education, consultancy within the legal boundary of Indian Judiciary System.

6. Responsibilities of CISI/CTIF India

In addition to the responsibilities mentioned under Articles 3 & 4 above, CISI shall be responsible for the following:

CISI will develop and control the vision, activities and functioning style and all other operative matters for ICTI jointly with other stakeholders and partners.

CISI and its partners involved with CTIF India will be responsible also to create the infrastructure and academic infrastructure by way of raising funds through investments programs/initiatives/funding schemes and CISI also will be responsible to involve its members in development of ICTI especially the industry members to create research laboratories, attract professors, faculty and students of Maharashtra by sharing standardized process, equipment etc.

10. **Compliance with the Law** and **Compliance with the Parties' Obligations**

10.1. **Compliance**

This MOU shall be in full compliance with the laws of the Republic of Bulgaria and the laws of the Technical University of Sofia and shall not be in violation of any laws, regulations, or other provisions of law applicable to the Parties. Each Party shall be responsible for ensuring compliance with all applicable laws and regulations.

Performance under this MOU shall be subject to the laws, regulations, and professional codes that the Parties' respective countries and jurisdictions with which the Parties' membership have and regulates applicable to the Parties' respective countries and jurisdictions.

11. **Duration**

This MOU shall enter into force on the date of its signing by the Parties and shall last for 3 years. The Parties may agree to prolong the duration of this MOU. Such Agreement shall be specific in writing.

12. **Termination**

This MOU expires automatically on March 31, 2025, unless the parties have agreed in writing to extend the term of this Agreement.

Each Party is entitled to terminate this MOU in the event of substantial breach by the other Party of its obligations under this MOU. Termination should be made in writing with a two-month notice in advance.

In the event that this MOU is terminated with reference to any of the two paragraphs above, the parties involved shall make their best efforts to ensure that such termination shall not have significant consequences for the Ph.D.-students already enrolled at Technical University of Sofia, provided always that General Principles or other agreements to be entered into by the Parties are respected.

For IIT I

Place and date

[Signature]

For Technical University of Sofia

Place and date

[Signature]

Dr. V. K. Bhatnagar
Secretary, Vishwaniketan

Dr. V. K. Bhatnagar
Tech. Univ. of Tel. Communication

For GISTE:

Place and date

[Signature]

[Signature]

Prof. Ramprasad
Chairman, GISTE

Manoj Bhatnagar
Rector

For Vishwaniketan:

Place and date

Mr. Anil K. Gupta
Trustee, Vishwaniketan,
Chairman, IIMRITM

Anil Kumar Gupta

TRUE COPY

MEMORANDUM OF UNDERSTANDING FOR COOPERATION

This Memorandum of Understanding for Cooperation is made by and between

International Institute for Innovation in ICT (IICIT)

Under a Licensee of

Represented by **Dr. Ashok Chandra, IICIT**

Vishwaniketan Campus, Survey No. 52, Kurubhivali, Khalapur

India

And

Global ICT Standardization Forum for India (GISFI)

Represented by **Prof. Ranjee Prasad, Chairman, GISFI**

And

Vishwaniketan

Represented by **Dr. S. S. Inamdar, Secretary**

Survey No. 52, Kurubhivali, Nr. Khalapur Todi Naka,

Off. Mumbai Pune Expressway, Tal. Khalapur, Dist. Raigad, Maharashtra

India

And

Research and Education Laboratory in Information Technologies (AIE)

Represented by **Spyridoula (Didde) Proukountou, Managing Director**

2, Adrianeiou and Papada str., 11525 Athens, Greece

1.1.1. MAU I

Whereas **International Institute for Innovation in Education (I²IIE)** has been established for the purpose of advancing the research, development and the academic excellence in education in the world all over the world with its unique objectives, the preference to award the scholarship to encourage and facilitating by the central agencies, Government of India, education, research and the industry.

Whereas **I4CT** will continue the best of the Indian Education and improve the quality of skills in education, research and entrepreneurship and will continue to provide the opportunity to world wide large number of India for world best.

Whereas **Global ICT Standardization Forum for India (GISFI)** has been established under society registration and Public Trust act in India and is an Indian national level body active in the area of Information and Communication Technologies (ICT) related application areas, such as energy, telemedicine, nuclear robotics, food technology and whereas GISFI addresses the research and product development of ICT in India and provides a bridge towards the globalization of the Indian achievements, the science, Technology, Governance and Development; and a platform for rising awareness of the importance and the internationalization of the higher education in the field as supported by the government of India.

Whereas **Vishwaniketan** is a registered trust/society initiated by professionals drawn from industry, education and administration with excellent experience of individuals who started creating a world class campus near Navi - Mumbai on Pune - Mumbai expressway and whereas Vishwaniketan will create a platform for students, teachers, researchers and professionals to adapt excellent teaching - learning practices inspired by Project Based Learning, encourage entrepreneurship and finally support product development through startups, and will empower teachers, business and the society by using technology solutions evolved and in doing so will promote values, ability of self-learning and taking responsibilities and self-esteem in all stake holders and therefore has hosted TIF India and GISFI and is willing to create I4CT in its campus.

Whereas **Research and Education Laboratory in Information Technologies (AIT)**, a non-profit Scientific Association has as its scope the development and promotion of Research, Science, Technology, Education and Training in the fields of Informatics, Telecommunication and Innovation Management, aiming for the strengthening of the Scientific, Technological, Research and Entrepreneurial Potential and Work Force of Greece, and the wider promotion of Research, Science and Education in the above mentioned fields.

Now, therefore, the Parties have agreed to enter into cooperation as described in this **MoU for Cooperation** (hereinafter referred to as the "Cooperation") - as follows:

TRUE COPY
Sd/-
(I4CT)

The purpose of the I4C initiative

The purpose of I4C is to create the all-India level of quality IIT-I technology platform and build diverse high level research and development center and academic institutions with global excellence providing quality education, research and other international facilities to collaborate internationally, including infrastructure, with the concept finally from all over world will be encouraged to create a world of knowledge spectrum of the student community worldwide. The purpose is also for AIT to strengthen its international relations especially to India and to become a preferred concept of future for Vishwavidyalaya, IIT, I and its partners in fields of economic, financial, importance and research.

Research will be focused for direct linkages to countries and world industry in India, Greece and global market. The global partners will receive an opportunity to understand and work with their respective markets of India and Greece for mutual benefit.

IIT-I will conduct M. S. and Ph. D. education and research programs in cooperation with AIT and other international partner universities and industry in accordance with the legislation in Greece/India.

The goal of I4C I is to

1. Create academic model of excellence with Problem Based Learning (PBL) methodology for ECE/EE courses in engineering with enrollment of 10000 students and 150 Ph.D students in various discipline of engineering, and 120 Ph.D students in Management every year.
2. Offer help/ass-stance/guidance/consultancy and other services to global user industry in the area of engineering and technology and PBL methodology to academic institutes in South Asia.
3. Initiate patent based research in engineering & technology and other qualities of education in India.
4. Create systems, platform for Indian academic institutes and industry for commercialization of research outcome of the scholars working in I4C I.
5. Encourage establishment of Joint Ventures of Industry partners from India and Europe for business Development in India for global Market.

1. The Parties

1.1 IACT

Indian Institute of Technology for Innovation (IIT-I) is to be established as an independent Research and Development center within Apsara Institute campus in close association with IITM under the flag of India. It will have initially seven research groups, namely Basic Telecommunications, Microsystems, Biotechnology, Telehealth Telemedicine, Cyberinformatics, Nanoelectronics and Technology Evolution & Applications. Basic Telecommunications will consist of four research sub-groups, namely, Network and Security, Navigation and Communication Systems, Radio Access Technology and Cognitive and Software Defined Radio. Artificial Intelligence and Computer Engineering, Information Technology, and Physical Science. The Research areas and fields of interest will be broadened from time to time as perceived in the near industry.

It is expected that the first areas to be added will be in the fields of Energy, Mechanical Engineering and Electrical Engineering.

IACT distinguishes itself from other Research and Development (R&D) initiatives by the expected impact of initial Indian-European development of world leading technology solutions with the primary objective of advancing education by using the PBL model commercialization of IPR out of research and techno entrepreneurship promotion at the level of Masters and Innovation & PhD level.

With IACT's application of PBL, the education system in India which is mainly targeted toward achieving a job will move to the domain of innovative research leading to commercialization.

Innovative research projects are expected to lead to Intellectual Property Rights (IPR) & IPR. It aims that the commercialization of the technology will give birth to the number of startup companies based on future technology leading towards the long term shift of R&D in India. IACT will have a holding company of its own which will provide self-sufficiency to the institute. All the startup companies will have shares in the institute's holding company; to run the holding company will provide funding to the institute to carry out further basic research in thrust area of IACT.

IACT will work in the larger interest of complex world and specifically for improvement in Academic and Corporate life of India as a whole. IACT may be supported by the government of India, the government of Denmark, Aalborg University, European Commission and any other Industry/Institution who wish to contribute to the objectives of IACT.

1.2 GISEI

GISEI will create a platform to facilitate discussions between bodies like major industrial countries or regions of the world and proactively interact in International forums such as ITC, IEEE, EISA, etc. GISEI will be a platform for discussions on standardization of

1. The first step is to identify the problem. This involves understanding the current situation and the goals that need to be achieved.

1. Identifying the problem and its objectives.
2. Gathering relevant information and data to understand the problem better.
3. Analyzing the information to identify the root causes and potential solutions.
4. Developing a plan of action, including identifying the resources needed and the steps to be taken.
5. Implementing the plan and monitoring progress.

CONCLUSIONS

The findings of this study indicate that the current system is not meeting the needs of the users. The main reasons for this are the lack of user involvement in the design process, the complexity of the system, and the lack of training and support for the users. To improve the system, it is recommended that the following steps be taken: 1. Involve users in the design process from the beginning. 2. Simplify the system and focus on the most important features. 3. Provide training and support for the users. 4. Monitor the system's performance and make adjustments as needed. 5. Regularly communicate with the users to gather feedback and address their concerns.

REFERENCES

The following references were consulted during the research process: [1] Smith, J. (2018). *Human-Computer Interaction: Principles and Practices*. New York: McGraw-Hill. [2] Jones, K. (2017). *User-Centered Design: A Guide to Creating User-Focused Products*. San Francisco: No Starch Press. [3] Nielsen, J. (2011). *Usability Engineering: The New Touchscreen Revolution*. San Francisco: No Starch Press. [4] Tognoli, A. (2013). *Designing for Usability: The Principles and Practices of User-Centered Design*. San Francisco: No Starch Press.

Practical experience and knowledge in the field of user-centered design. All the research outputs are available in full-text format through the following URL: <https://www.researchgate.net/publication/350000000>

- Research goal achieved. In fact, the results of active involvement in design research (including, for example, the use of the Design Structure Matrix) are clearly reflected in the research results of the project.
- Strong emphasis on R&D process of design and usability. Through the various activities and collaborations, we have established a strong relationship between the user and the design process.
- Addressing research challenges. The results indicate a number of research-related and research projects, as well as topics that give a clear indication of progress in the participating companies, both in terms of the number of projects and the quality of the results.
- Further work. The results of the project are being used to improve the design process in the company. The results of the project are also being used to inform the field of human-computer interaction and usability research. The project has also led to the development of a number of research projects.

1. To provide a world class long term research oriented education to students of a university in India.

3. Organization

It is to be established as an independent Research and Development center under Public Private Partnership (PPP) Model. It will work on the objectives mostly as follows:-

1. To register at least 100 Ph.D. students in the identified areas on engineering technology and other areas, and subject research oriented activities to world industry.
2. To promote "Transfer by PhD students" for Asia to improve the teaching learning practices in research institutes, introducing PhD methodology.
3. To register at least 10% patents out of the work done by the PhD students under the guidance of the eminent researchers all over the world.
4. Offer help to national producers/entrepreneurs and other services to user industry in engineering technology and all other areas.

Regarding IACIT, the stake holders and partners i.e. IITSI, Vishwanketan, Vajbhoy University, AIT and other industry partners will be involved in the mode of "proportionate ownership on the investment they are doing" for fulfillment of these objectives.

Following organizational structure will be adopted for fulfillment of the goals and the objectives already defined.

1. GSIPL, the partners involved with CUE India and Vishwanketan will develop and control the vision, activities and functioning style and all other operative matters for IACIT.
2. The ownership of the IACIT will be with the governing body of IIT members, ensuring appropriate involvement of all stake holders and partners, which will be decided in the due course of time.
3. The governing body will consist of eleven members to be decided from time to time depending upon the involvement and investment made by the stake holders and institute/industry.
4. An organizational structure will be evolved as per existing styles in a world class academic research institute for the fulfillment of the vision of IACIT.

The establishment and running of IACIT will be absolute responsibility of the governing body of IACIT.

4. Facilities

Vishwanketan will make available 16 acres (42000 mtr. Sq.) of land for IACIT. On this land, IACIT will build a research facility in the domain as decided by the governing body.

The long duration of the project (10-12 years) will be divided into three well coordinated sub-phases, as mentioned below, to be undertaken by Vishwaniketan.

During the first phase, of 18 months, the project proposed Vishwaniketan will provide research facilities of about 2000 sq. meters to house the research facilities the duration of which might not exceed three years after the opening of IIT.

Most educational and research activities will shift into the building constructed in phase 1 (IIT) management. Vishwaniketan and IIT shall, as stated below, be solely and fully responsible for managing and maintaining the research facility. It shall be the responsibility of IIT building, utilities and laboratories and their coverages and all running cost for the facility.

5. Responsibilities of IACT

In addition to the responsibilities mentioned under Articles 3 & 4 above, IACT shall be responsible for the following:

IACT will conduct Masters and PhD programs in collaboration with IIT, GSIIF and other universities/Institutional partners in accordance with the laws and regulations applicable.

IACT will introduce and conduct a 1-1 'co-learning' programme for IIT/IIT students with universities and research centres abroad for 45 days training on priority, PBL, specific courses on recent advancements in special learning on topics of common interests.

IACT will conduct undergraduate programs in cooperation with Vishwaniketan and IIT, IIT providing always that the relevant and necessary approvals and permissions are granted under national legislation, of the countries involved.

Up to 100 PhD or graduate candidates will be registered per year under the supervision of competent professors and practitioners from Europe and India.

Finally IACT will provide its expertise to all stake holders for exploring possibilities of their expansion in the huge market of India in education, consultancy within the legal boundary of Indian Judiciary System.

6. Responsibilities of GSIIF/CITF India

In addition to the responsibilities mentioned under Articles 3 & 4 above, GSIIF shall be responsible for the following:

GSIIF will develop and control the vision, activities and functioning style and all other operative matters for IACT jointly with other stake holders and partners.

GSIIF and the partners involved with CITF India will be responsible also to create the laboratories, other academic infrastructure by way of raising funds through investments

Whenever a partner institution requests to send students to AIT for a short-term visit, the partner institution will send a request to AIT. If approved, the partner institution will be responsible for the travel and accommodation expenses of the students and also for their insurance.

The AIT's cost of USD 1000 (INR 110000) will be in addition to the partner institution's cost of all other the expenses of the students. Further, the partner institution will be responsible for the health insurance of the students. AIT will not be responsible for the health insurance of the students.

7. Responsibilities of Vishwaniketan

In addition to the responsibilities mentioned under Section 6, Vishwaniketan will be responsible in provision of the following support to the partner institution of IITC.

Vishwaniketan will, if necessary, provide residence to the maximum of Indian faculty, PhD post graduates, PhD students of IITC for a period of three years.

The chargeable for the hostel facility will be according to the actual position of Vishwaniketan for other students staying in the campus. The staff quarters will also be made available to professors, faculty, PhD students, postgraduates and undergraduates students of the IITC on non-chargeable basis for the reasonable amount, depending upon availability. All the expenses for utility such as ground water, electricity, communication, banking etc. will be made as per the IITC by giving the most rational/decided charges in line with existing norms.

In addition, Vishwaniketan may offer teaching assignments to the faculty and PhD students of IITC on remuneration (work scholarship) based on visiting practices of Vishwaniketan. The eligible faculty of Vishwaniketan may be involved in teaching, research activities of IITC on remunerative basis based on prevailing norms.

Furthermore, Vishwaniketan will establish center for PhD studies to improve the academic quality of interested Engineering Colleges in the AIT-GISTE-Vishwaniketan Network amongst around 3500 engineering colleges in India. The PhD center of excellence may offer its service to institutions all over south Asia. Vishwaniketan will invite AIT to cooperate in this initiative on mutually agreed terms and conditions.

8. Responsibilities of AIT

Whenever AIT enters into cooperation with partners in India regarding the education of PhD, MS and undergraduate students, the general principles for this cooperation will be added as Appendix to this MOU. This general principle will be replaced by a more detailed agreement to be entered into by AIT and Vishwaniketan.

AIT will provide necessary information regarding existing PhD programs and additional information regarding requirements, fees and conditions for granting PhD students in the field of programs to which admission is regarding the course of the PhD studies.

A provision initiative is expected from AIT of administrative programs like the PhD program who is to cover all the main aspects of the cooperation as well as other matters which are launched with reference to this MoU. AIT is also expected to engage in faculty exchange, administrative staff, joint research activities and students to be agreed by the involved Parties.

In view of the status of the PhD program and of the individual students, the Parties agree that Vitswankem will admit potential students and make recommendations regarding eligible students to AIT. AIT will consider accepting eligible students upon Vitswankem's recommendation supplemented by interviews and written assignments performed by supervisors and staff representing the relevant Doctoral School.

The PhD-studies shall be completed (measured) with an Appendix of the MoU.

AIT will, in cooperation with Vitswankem, make efforts to achieve external funding for joint activities, such as bilateral research projects, network activities, establishment of laboratories at IACT, scholarships, training courses, faculty exchange, etc. as its proportionate investment in IAC.

AIT wishes to offer MScMS and PhD integrated programs. As per the signing of the MoU, it is unclear what the possibilities will be under both Greek and Indian legislation.

AIT will consider offering 45 days training programs on the content courses project to be developed jointly for the undergraduate students of IAC Network in India. AIT is also expected to proactively involve and sharing of lectures, conferences conducted at AIT through video conferencing. AIT will provide faculty for short-term trainings of faculty and students of IACT, or IIT offices and will also give full access to the laboratories and library for the students and faculty of IACT. Further details, such as methodology, fee structure, etc. will be agreed by the involved Parties and shall be included in a separate annex to this Cooperation Agreement.

A Principle of 85% Tuition waiver will be considered for all such fellowships; a proactive approval will be taken by AIT to increase interest of Indian students in all such fellowships.

3. Financial issues

There is no money to be paid between the Parties under this MoU.

10. Compliance

10.1. IISIL shall ~~endeavour to ensure~~ ensure that this MoU is in compliance with relevant and mandatory laws and rules. IIT shall not in any way be held responsible or liable for any kind of violation of IIT and/or IISIL which violates the laws and rules and regulations of Government of India and all component authority concerned.

Furthermore IIT shall ensure that projects which is launched and performed under this Memorandum of Understanding is in compliance with relevant and mandatory laws and regulations applicable for the parties concerned.

11. Duration

This MoU shall enter into force by Jan^y 2016 and shall be in force for 5 years. The Parties may agree to prolong the duration of this MoU. Such Agreement shall be made in writing.

12. Termination

This MoU expires automatically per May 31st 2019 unless an addendum has been made c.f. Article 12 above and unless it has been terminated of this Article.

Each Party is entitled to terminate this MoU in the next of substantial breach by another party of its obligations under this MoU. Termination should be made in writing with a two months' notice in advance.

In the event that this MoU is terminated with reference to any of the two paragraphs above, the parties involved shall make their best efforts to ensure that such termination shall not have significant consequences for all running activities, provided always that General Principles or other agreements in he entered into by the Parties are respected.

SECRETARY

For IIC I

Place and date

Dr. Ashish Chandra

For GISFI

Place and date

Pptl Ranjee Prasad
Chairman, GISFI

For Vishwaniketan:

Place and date



Secretary

Dr. S. S. Jandhir
Secretary, Vishwa-Nitetan
Vishwaniketan No E-9819 Raigarh

For AII

Place and date

RESEARCH AND INVESTIGATION LABORATORY
IN INFORMATION TECHNOLOGIES (RIL) AT
"ATHENS INFORMATION TECHNOLOGY" (AII)
NON PROFIT ORGANIZATION IN 2008/2009
100100 BANGKOK 101100 TEL: 0066 2 251 1111
P.O. BOX 111111 - FAX: 0066 2 251 1111
TEL: +30 276 88888 - FAX: +30 276 88888

Syridulha Dhalat Prasadman
Managing Director

TRIE 000

Signature

For CGC and CSDI

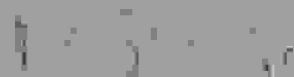

Prof. Ramesh Prasad

President CGC & Chairman CSDI

For Aarhus University:



Prof. Anker Sankhakar

Chairman, CSDI

For Vishwaniketan

Place and Date

Hermit, Dehradun, 23 April 2017



Dr. S. S. Inamdar

Managing Trustee and Secretary

For Aarhus University:

Place and Date

Hermit, Dehradun, 23 April 2017



Prof. Anker Sankhakar

Head of the Department of Business
Development and Technology



COOPERATION AGREEMENT

for UG fellowship

This Memorandum of Understanding for Cooperation is made by and between

Vishwaniketan

Represented by Prof. S. S. Inamdar

Survey No. 52, Kumbhivadi, Nr. Khalapur Toll Naka,

Off. Mumbai-Pune Expressway, Tal. Khalapur, Dist. Raigad, Maharashtra

India

And

Interdepartmental Center CTIF, University of Rome Tor Vergata

(hereafter called CTIF-Italy)

Represented by Prof. Massimiliano Coletta

Via del politecnico 1,

00133 Rome

PREAMBLE

Whereas **Vishwaniketan** is a registered trust/society initiated by professionals drawn from industry, education and administration with excellent experience of individuals. has started creating a world class campus near Navi - Mumbai on Pune - Mumbai expressway and whereas **Vishwaniketan** will create a platform for students, teachers, researchers and professionals to adopt excellent teaching - learning practices inspired by Project Based Learning, encourage entrepreneurship and finally support product development through startups, and will empower teachers, business and the society by using technology solutions evolved and in doing so will promote values, ability of self-learning and taking responsibilities and self-govern in all stake holders.

Vishwaniketan realizes that there is an acute need to transform professional education in India to create ready to use man power for industry, to inculcate innovative thinking in student community and to empower teaching community. It has strong belief that the education model of **University of Rome Tor Vergata** has the potential to do this

CTIF-Italy is an Interdepartmental Center of the University of Rome Tor Vergata. CTIF-Italy is situated at the University of Rome Tor Vergata (Italian: Università degli Studi di Roma Tor Vergata)



TRUE COPY

[Handwritten signature and date]

is a university located in Rome, Italy. It is one of the largest research-based institutions in Italy. The University is an international center for research and education and it is well known for scientific studies. In recent years the activity of technology transfer and cooperation with other public and private organizations in different fields has obtained an increasingly important role. The University of Rome Tor Vergata was established in 1981 with the goal of providing high quality education for students preparing to meet the ever-evolving needs and opportunities of the 21st century workforce.

CTIF-Italy has its objective research and educational activities in the field of development of interdisciplinary applications of *Information and Communication Technology (ICT)*. The activity subject of this agreement is expected to increase the interest of these students to join **University of Rome Tor Vergata MS Programme** in a later stage.

CTIF-Italy and Vishwaniketan agree to the following:

Article 1: **CTIF-Italy**, will offer 45 days training programmes on the content / courses / projects to be developed jointly for the undergraduate students of CTIF- Vishwaniketan Network in India.

Article 2: Indian undergraduate students in engineering, who have completed 2/3 years of their studies will be the participants/candidates of the UG Fellowship programme. The students who have completed at least three good projects in our PBL method, will be selected by Vishwaniketan for this fellowship/ project internship of 6 weeks. (15th June to 30th July every year, tentatively).

Article 3: The supervisor/professor shall give guidance to students through personal meetings, tutorials, classroom teaching if necessary and daily supervision by a junior staff member. The PBL approach involves guidance only if the student is not able to solve the problem. Review presentations fortnightly may be arranged for smooth/meaningful completion of the higher end project. At the end, a certification will be done by CTIF-Italy.

Article 4: Areas of interest for the Indian students are mechanical, electrical, energy, civil, electronics communication, wireless, robotics, automation, 5G, computer/software engineering but not limited to such areas.

Article 5: Any expenses of the visiting student related to the visiting period, such as Daily expenses, accommodation fee, personal medical coverage and insurance for civil liability against third parties need to be covered by the visiting student. No money contribution will be reimbursed by Tor Vergata University to the Visiting student.

Article 6: The present agreement will remain valid for 1 years. It may be renewed for the same period upon request of one of the parties.

Rome,

Coordinator of the Interdepartmental Center CTIF

Prof. *Massimiliano Colletta*

Vishwaniketan

Prof. S. S. Iyengar



TRUE COPY
S. S. Iyengar
Vishwaniketan (S. S. Iyengar)

Annex 1. Prerequisites 1

The list of candidates who will be invited to participate in recruitment procedure is published on the website of the Federal University of Science and Technology after the vote of the President of the Federal University of Science and Technology in the information system of the Federal Agency for Higher Education and Scientific Research.

с. ДИГ 106

Список кандидатов, приглашаемых на участие в процедуре отбора, опубликован на сайте Федерального университета науки и технологий после голосования Президента Федерального университета науки и технологий в информационной системе Федерального агентства по высшему образованию и научным исследованиям.

No	Name, Surname / ФИО	Sex / Пол	Country of Residence / Страна проживания	Date of birth / Дата рождения	Passport number / Номер паспорта
1.	IMADAB BAVASHA RAJ AMBAR	M	India	10/06/1986	686121545

Vishwanath Institute of Management, Entrepreneurship and Engineering Technology

Dr. B. S. Dandath



Dr. B. S. Dandath
Principal, VITMEE

The Federal University named after the 100th Anniversary of the President of the Russian Federation, V. V. Putin

Dr. V. V. Dandath



Dr. V. V. Dandath

Сторона 1
to the Contract No 07 dated 18.07.2018

... (partially obscured)

Протокол №2
к договору № 1 от 18.07.2018

Ак: протокол, 18-е июля 2018 года

«Customer and «Provider» will also be responsible for acceptance of rendered services in limited by terms and conditions of the contractual clause

«Solution for design and research tasks in mechanical engineering» period since 19.06.2018 till 30.07. 2018.

Ekaterinburg, maximum 1 person

Parties agreed that all services rendered appropriately, efficiently and met the requirements and conditions of the Customer. Parties do not have any financial or other claims.

«Исполнитель и «Пользователь» также будут ответственны за приемку оказанных услуг в пределах, определенных условиями и условиями договора

«Решение проектно-конструкторских и исследовательских задач в машиностроении» в период с 18.06 - 30.07 2018 г. Екатеринбург, максимум 1 человек

Стороны согласились, что услуги выполнены в полном объеме и в полном соответствии с требованиями Заказчика. Стороны не имеют друг к другу никаких финансовых или иных претензий

PREREQUISITES AND SIGNATURES OF PARTIES

Customer:
Vishwaniketan Institute of Management
Entrepreneurship and Engineering Technology
Secretary

Dr. S. S. Inamdar

Secretary

Секретарь
Исполнитель, Дев. Мандал

Provider:
ООО «Уника» (LLC «Unika»)

Director:

Vladislav V. Pivan

M. P.

РЕКВИЗИТЫ И ПОДПИСИ СТОРОН

Заказчик:
Институт менеджмента, предпринимательства и инженерных технологий Вишваникетана

Док. С. С. Инамдар

Исполнитель,
ООО «Уника»

Директор

M. P.

Секретарь

Исполнитель

Исполнитель, Дев. Мандал

Исполнитель, Дев. Мандал



TRUE COPY

18.07.2018



April 19, 2017

Dear Dr. Arvind Kulkarni:

Re: Visiting Researcher Invitation

I am happy to support you as a Visiting Researcher in the Electrical and Computer Engineering Department at the Stevens Institute of Technology from June 1st, 2017 to July 1st, 2017.

We will collaborate on machine learning for robotics/autonomous driving this year. Your background in robotics and your research in machine learning are highly synergistic. Stevens will provide you with office space, access to my research laboratory, facilities such as the library, etc. I look forward to a fruitful research collaboration.

Please let me know if you have any questions.

Founded in 1831 as America's First Faculty of Engineers — who pioneered steam turbines and the modern form of railroad track, among many other inventions — technological innovation has remained the backbone of Stevens education and research programs ever since.

Today, within the university's three schools and one college, 8,000 undergraduates and graduate students collaborate with more than 200 faculty members in an interdisciplinary, student-centric, entrepreneurial environment to advance the frontiers of science and leverage technology to confront global challenges.

Stevens remains committed, more than 40,000 strong, also committed to make national and global impact while contributing energy, ideas and support to the continued growth and innovation of the university.

Regards

Prof. Rajarathnam Chandrasekar
Thomas G. Bennett Chair Professor
raj@stevens.edu
Tel: +1-201-324-6542

<http://www.stevens.edu>



Certificate of Completion

This certificate is awarded to

Namrit Mehta

For successfully completing the

2017 Summer Research Internship on Software Defined IoT

A handwritten signature in black ink, appearing to read "R. Chandramouli".

Rajarathnam Chandramouli

Thomas Hattrick Chair Professor

Schaefer School of Engineering and Science



STEVENS

INSTITUTE OF TECHNOLOGY

TRUE COPY

[Handwritten signature]
2017 Summer

The Agreement...
for use in favor of the...
of Title... 2019

1.4 Purpose of Agreement

1.1 The parties agree to...
to provide...
to provide...

1.2 The parties agree to...
to provide...
to provide...

1.3 "Mutual Definition" is a part of the Agreement that...
to provide...
to provide...

1.4 "Mutual Definition" is a part of the Agreement that...
to provide...
to provide...

2.0 Term, Renewal, and Termination

2.1 This Agreement shall be effective on the 1st day of February, 2019, and shall terminate on the 1st day of September, 2019.

2.2 This Agreement may be voluntarily renewed for...
to provide...
to provide...

THIS COPY

1. Faculty
2. Students
3. Faculty

4. Faculty
5. Faculty
6. Faculty

4.1. Academic - The institution is proposing to undertake study with the following faculty under a special arrangement with the institution in the following circumstances:

4.1.1. Academic - The institution is proposing to undertake study with the following faculty under a special arrangement with the institution in the following circumstances:

4.1.2. Academic - The institution is proposing to undertake study with the following faculty under a special arrangement with the institution in the following circumstances:

4.1.3. Academic - The institution is proposing to undertake study with the following faculty under a special arrangement with the institution in the following circumstances:

4.2. Academic - The institution is proposing to undertake study with the following faculty under a special arrangement with the institution in the following circumstances:

4.3. Academic - The institution is proposing to undertake study with the following faculty under a special arrangement with the institution in the following circumstances:

5.0 Joint Research Projects

5.1. In the event a joint research project is proposed by either party, the following shall be carefully considered by both parties to evaluate the need for the same, the qualifications of the proposed participating faculty members, and the feasibility of the research activity. If a decision is made by both parties to approve the proposed project, a possible arrangement for both institutions to share resources and funding for the proposed joint research project prior to their final approval and implementation of the joint project.

5.2. In such joint projects between the two institutions, care shall be taken to ensure that

10
11
12
13
14

15
16

17
18
19
20

21
22
23

24
25
26
27
28
29
30
31
32
33
34
35
36
37
38
39
40
41
42
43
44
45
46
47
48
49
50
51
52
53
54
55
56
57
58
59
60
61
62
63
64
65
66
67
68
69
70
71
72
73
74
75
76
77
78
79
80
81
82
83
84
85
86
87
88
89
90
91
92
93
94
95
96
97
98
99
100
101
102
103
104
105
106
107
108
109
110
111
112
113
114
115
116
117
118
119
120
121
122
123
124
125
126
127
128
129
130
131
132
133
134
135
136
137
138
139
140
141
142
143
144
145
146
147
148
149
150
151
152
153
154
155
156
157
158
159
160
161
162
163
164
165
166
167
168
169
170
171
172
173
174
175
176
177
178
179
180
181
182
183
184
185
186
187
188
189
190
191
192
193
194
195
196
197
198
199
200
201
202
203
204
205
206
207
208
209
210
211
212
213
214
215
216
217
218
219
220
221
222
223
224
225
226
227
228
229
230
231
232
233
234
235
236
237
238
239
240
241
242
243
244
245
246
247
248
249
250
251
252
253
254
255
256
257
258
259
260
261
262
263
264
265
266
267
268
269
270
271
272
273
274
275
276
277
278
279
280
281
282
283
284
285
286
287
288
289
290
291
292
293
294
295
296
297
298
299
300
301
302
303
304
305
306
307
308
309
310
311
312
313
314
315
316
317
318
319
320
321
322
323
324
325
326
327
328
329
330
331
332
333
334
335
336
337
338
339
340
341
342
343
344
345
346
347
348
349
350
351
352
353
354
355
356
357
358
359
360
361
362
363
364
365
366
367
368
369
370
371
372
373
374
375
376
377
378
379
380
381
382
383
384
385
386
387
388
389
390
391
392
393
394
395
396
397
398
399
400
401
402
403
404
405
406
407
408
409
410
411
412
413
414
415
416
417
418
419
420
421
422
423
424
425
426
427
428
429
430
431
432
433
434
435
436
437
438
439
440
441
442
443
444
445
446
447
448
449
450
451
452
453
454
455
456
457
458
459
460
461
462
463
464
465
466
467
468
469
470
471
472
473
474
475
476
477
478
479
480
481
482
483
484
485
486
487
488
489
490
491
492
493
494
495
496
497
498
499
500
501
502
503
504
505
506
507
508
509
510
511
512
513
514
515
516
517
518
519
520
521
522
523
524
525
526
527
528
529
530
531
532
533
534
535
536
537
538
539
540
541
542
543
544
545
546
547
548
549
550
551
552
553
554
555
556
557
558
559
560
561
562
563
564
565
566
567
568
569
570
571
572
573
574
575
576
577
578
579
580
581
582
583
584
585
586
587
588
589
590
591
592
593
594
595
596
597
598
599
600
601
602
603
604
605
606
607
608
609
610
611
612
613
614
615
616
617
618
619
620
621
622
623
624
625
626
627
628
629
630
631
632
633
634
635
636
637
638
639
640
641
642
643
644
645
646
647
648
649
650
651
652
653
654
655
656
657
658
659
660
661
662
663
664
665
666
667
668
669
670
671
672
673
674
675
676
677
678
679
680
681
682
683
684
685
686
687
688
689
690
691
692
693
694
695
696
697
698
699
700
701
702
703
704
705
706
707
708
709
710
711
712
713
714
715
716
717
718
719
720
721
722
723
724
725
726
727
728
729
730
731
732
733
734
735
736
737
738
739
740
741
742
743
744
745
746
747
748
749
750
751
752
753
754
755
756
757
758
759
760
761
762
763
764
765
766
767
768
769
770
771
772
773
774
775
776
777
778
779
780
781
782
783
784
785
786
787
788
789
790
791
792
793
794
795
796
797
798
799
800
801
802
803
804
805
806
807
808
809
810
811
812
813
814
815
816
817
818
819
820
821
822
823
824
825
826
827
828
829
830
831
832
833
834
835
836
837
838
839
840
841
842
843
844
845
846
847
848
849
850
851
852
853
854
855
856
857
858
859
860
861
862
863
864
865
866
867
868
869
870
871
872
873
874
875
876
877
878
879
880
881
882
883
884
885
886
887
888
889
890
891
892
893
894
895
896
897
898
899
900
901
902
903
904
905
906
907
908
909
910
911
912
913
914
915
916
917
918
919
920
921
922
923
924
925
926
927
928
929
930
931
932
933
934
935
936
937
938
939
940
941
942
943
944
945
946
947
948
949
950
951
952
953
954
955
956
957
958
959
960
961
962
963
964
965
966
967
968
969
970
971
972
973
974
975
976
977
978
979
980
981
982
983
984
985
986
987
988
989
990
991
992
993
994
995
996
997
998
999
1000

1.3 Dispute Resolution

1.3.1 Disputes shall be resolved through the dispute resolution mechanism established in the Agreement, and shall be resolved in accordance with the dispute resolution mechanism established in the Agreement.

1.3.2 All research and other activities shall be conducted in accordance with the laws, rules, and regulations applicable in the United States. In the case of language barriers, there are the following provisions:

1.4 Administrative and Disciplinary Rules

The parties agree that the academic requirements of all educational institutions shall be reviewed and the administrative and disciplinary requirements of academic institutions and social discipline will be distributed to the other party.

1.5 Budgetary Commitments

Commitments for implementation of the Agreement shall come from either party. Depending upon budgetary availability, neither party is obligated to expend any resources in connection with this Agreement. No implementation of any portion of this Agreement is contingent upon any specific resources being available prior to the written agreement of each party. In the event any material funding is required by institutions in order to implement this Agreement and funding for such purposes is not appropriated to institutions or is not available to institutions, the institutions that have no further financial obligations shall

TRUST

1.1.1 Term of Agreement

1.1.2 Independent Contractors

1.1.3 Relationship of Parties
The parties to this Agreement shall be independent contractors, and shall not be deemed to be employees, agents, or partners. The parties to this Agreement shall not be deemed to be employees, agents, or partners of each other for purposes of any laws, regulations, or other employment-related obligations that may apply to any one or more of the parties to this Agreement.

1.2 Relationship of Parties

The Agreement shall be entered into by the parties to this Agreement as independent contractors, and shall not be deemed to be employees, agents, or partners. The parties to this Agreement shall not be deemed to be employees, agents, or partners of each other for purposes of any laws, regulations, or other employment-related obligations that may apply to any one or more of the parties to this Agreement.

1.3 Local Laws, State, Federal, and Foreign

Neither party shall use the other as a means of circumventing any laws, regulations, or other employment-related obligations that may apply to any one or more of the parties to this Agreement. The parties to this Agreement shall not be deemed to be employees, agents, or partners of each other for purposes of any laws, regulations, or other employment-related obligations that may apply to any one or more of the parties to this Agreement.

1.4 Governing Law Forum

This Agreement shall be governed by and construed under the laws of the State of Delaware, which shall be the forum for any lawsuits arising from or incident to this Agreement.

1.5 Waiver

A waiver of any breach of any provision of this Agreement shall not be construed as a waiver of any other breaches of the same or other provisions of this Agreement.

1.6 Non-Assignment

This Agreement may not be assigned by either party without the written consent of the other. This Agreement shall be binding upon the heirs, personal representatives, and assigns of the parties to this Agreement.

IN WITNESS WHEREOF, I have hereunto set my hand and seal of office this _____ day of _____, 2017.

Name of the Officer

Signature of the Officer

Name of the Officer

Title of the Officer

Signature of the Officer

Name of the Officer

Title of the Officer

This document is valid only when signed by the Officer in Charge of the Institution and the Officer in Charge of the University of Arkansas at Little Rock. It is not valid if signed by any other person.

IN WITNESS WHEREOF, I have hereunto set my hand and seal of office this _____ day of _____, 2017.

INSTITUTION

UNIVERSITY OF ARKANSAS AT LITTLE ROCK

Head of Institution of the University of Arkansas at Little Rock on behalf of the University of Arkansas at Little Rock

Managing Trustee of
Yashwantrao Chavan Pratishthan, India

by _____

by _____

(Signature)
Eman McClinton

(Signature)
Dr. Sandeep S. Inander

(Printed Name)

(Printed Name)
Managing Trustee of Yashwantrao Chavan Pratishthan

(Title)

(Title)
Trustee

TRUE COPY

Signature of the Trustee

Cooperation Framework Agreement

December, 01, 2016

The National Institute of Technology of Uttarakhand (NITU) and VIT-AP, represented by its Vice-Chancellor (Professor) J. G. S. Jeyaraman

And VIT-AP, represented by its Managing Director, Dr. V. V. Srinivasulu Murthy, have agreed to cooperate in the following manner:

Recognising

Successes of educational and research level in the

Pursuing to

Observance of the national legislation norms of each of the Parties and cooperation solely for mutual purposes.

Aiming to

Strengthening of bilateral international cooperation level in the following areas:

1. Subject

The joint cooperation implementation and having an advantage of scientific and educational potentials of the Parties, the list shall carry out following kinds of cooperation:

Educational activity:

- Exchange by educational and study guides, including soft copies.
- Exchange by experience and information concerning educational process, methodology, etc. support,

- team development, joint preparation and publishing of educational and study guides, including soft copies taking into account observance of intellectual property rights of authors and both Parties.

- Carrying out of homework on development of distance educational technologies,

- Carrying out of joint research and methodology conferences on educational distance.

- Organisation of both Parties' teachers professional skills improvement by mutual training.

- Both Parties' teachers exchange for lecturing on the themes coordinated by the Parties.

- All types of academic mobility, students, trainees exchange.

- Cooperation in the framework of joint educational projects.

- Implementation of joint educational programs.

Vishwaniketan will start sending three groups of students for summer training in mechanical, electronics and energetics departments, totaling approximately 70 students for six week training starting in June 2017.

Research activity:

- Joint carrying out of researches, sharing of achieved results, publications of articles in scientific journals and website collections of scientific works.

- Mutual special purpose exchange of post-graduate and doctoral students of the Parties.

- Organisation of mutual framing of scientific, pedagogical and teaching staff of the Parties.

- Joint implementation of the projects being a part of large scientific and technical international programs.

- Joint organisation of international research and practice conferences.

- Providing of conditions for use by scientific, pedagogical and teaching staff of the Parties of facilities and resources as well as equipment of the Parties on an equal and reciprocal basis.

NITU

Signature

Date

Place

Date: _____
Place: _____
To: _____
From: _____
Subject: _____

1. Objectives of the Agreement

- 1.1 To establish a framework for cooperation between the two institutions in the field of research and development.
- 1.2 To promote the exchange of information and expertise between the two institutions.
- 1.3 To provide a platform for joint projects and initiatives.

2. Scope of the Agreement

2.1 The Agreement shall apply to all activities related to the field of research and development, including but not limited to the following:

- 2.1.1 Joint research projects and initiatives.
- 2.1.2 Exchange of information and expertise.
- 2.1.3 Provision of facilities and resources.
- 2.1.4 Publication of research results.

2.2 All changes and alterations to the Agreement shall be subject to the mutual agreement of both institutions.

2.3 Each of the Parties shall have the right to terminate the Agreement if the other Party fails to fulfill its obligations under the Agreement.

2.4 The Parties shall be obliged to comply with all applicable laws, regulations, and standards, including but not limited to the following:

- 2.4.1 Intellectual property rights.
- 2.4.2 Confidentiality.
- 2.4.3 Data protection.

2.5 The Agreement shall be signed in English and Ukrainian, and both versions shall be equally valid and binding.

2.6 The Parties shall be responsible for the costs of the Agreement, including but not limited to the following:

- 2.6.1 Printing and distribution costs.
- 2.6.2 Translation costs.
- 2.6.3 Legal fees.

2.7 The Parties undertake to use their best efforts to make all decisions relating to the Agreement by mutual agreement.

3. Details and Signatures of the Parties

National Technical University of Ukraine
"Igor Sikorsky Kyiv Polytechnic Institute"
Prof. _____
Vice-Rector

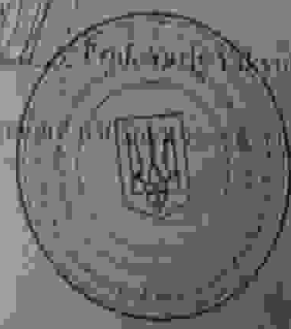

Yalta, Ukraine
Prof. _____
Prof. handover founder

Методичні прозовирання передбачають розробку і виконання завдань, які сприяють формуванню у школярів уявлень про роль науки у розвитку людства, а також розуміння сутності наукових досліджень і наукової роботи вчених. Методичні прозовирання передбачають розробку і виконання завдань, які сприяють формуванню у школярів уявлень про роль науки у розвитку людства, а також розуміння сутності наукових досліджень і наукової роботи вчених.

Методичні

методичні прозовирання передбачають розробку і виконання завдань, які сприяють формуванню у школярів уявлень про роль науки у розвитку людства, а також розуміння сутності наукових досліджень і наукової роботи вчених.

Завдання

Методичні прозовирання передбачають розробку і виконання завдань, які сприяють формуванню у школярів уявлень про роль науки у розвитку людства, а також розуміння сутності наукових досліджень і наукової роботи вчених.

Методичні прозовирання передбачають розробку і виконання завдань, які сприяють формуванню у школярів уявлень про роль науки у розвитку людства, а також розуміння сутності наукових досліджень і наукової роботи вчених.

І. Предмет

Використання предметних методичних прозовирань передбачає розробку і виконання завдань, які сприяють формуванню у школярів уявлень про роль науки у розвитку людства, а також розуміння сутності наукових досліджень і наукової роботи вчених.

Особисті вимоги:

- Уміти швидко і точно розв'язувати задачі, які вимагають використання знань з предмету.
- Уміти працювати з інформацією, яку отримано з різних джерел, і використовувати її для розв'язання завдань.
- Уміти працювати з електронними джерелами інформації, зокрема з інтернетом, для пошуку необхідної інформації.

- Провести дослідження роботи з предмету, яке вимагає використання знань з предмету.
- Провести дослідження роботи з предмету, яке вимагає використання знань з предмету.

- Провести дослідження роботи з предмету, яке вимагає використання знань з предмету.
- Провести дослідження роботи з предмету, яке вимагає використання знань з предмету.

- Провести дослідження роботи з предмету, яке вимагає використання знань з предмету.
- Провести дослідження роботи з предмету, яке вимагає використання знань з предмету.

- Провести дослідження роботи з предмету, яке вимагає використання знань з предмету.
- Провести дослідження роботи з предмету, яке вимагає використання знань з предмету.

Науково-дослідна діяльність

- Уміти працювати з інформацією, яку отримано з різних джерел, і використовувати її для розв'язання завдань.
- Уміти працювати з електронними джерелами інформації, зокрема з інтернетом, для пошуку необхідної інформації.

- Уміти працювати з електронними джерелами інформації, зокрема з інтернетом, для пошуку необхідної інформації.

- Уміти працювати з електронними джерелами інформації, зокрема з інтернетом, для пошуку необхідної інформації.

- Уміти працювати з електронними джерелами інформації, зокрема з інтернетом, для пошуку необхідної інформації.

- Уміти працювати з електронними джерелами інформації, зокрема з інтернетом, для пошуку необхідної інформації.

- Уміти працювати з електронними джерелами інформації, зокрема з інтернетом, для пошуку необхідної інформації.

- Уміти працювати з електронними джерелами інформації, зокрема з інтернетом, для пошуку необхідної інформації.

Інформаційна діяльність:

- Уміти працювати з інформацією, яку отримано з різних джерел, і використовувати її для розв'язання завдань.

- Уміти працювати з інформацією, яку отримано з різних джерел, і використовувати її для розв'язання завдань.

MEMORANDUM
Of
UNDERSTANDING
Between
VISHWANIKETAN'S
iMEET, KUMBHIVALI
And
MECHATOL ENGINEERING
SOLUTIONS, PUNE
(Training Agency)

TRUE COPY
[Signature]
Mishra & Co. (PVT) LTD.

1 Executive Summary

Memorandum of Understanding
Between
MEDHATOL ENGINEERING SOLUTIONS, PUNE
(Training Agency)
Vishwaniketan's (MEET, Kumbhivalli)(ViMEET)

1.1 Context

This MoU is hereby entered into by Vishwaniketan's (MEET, Kumbhivalli, Tal. Khalapur between MEDHATOL ENGINEERING SOLUTIONS, PUNE here in after referred to as the training agency. In the Vishwaniketan's (MEET, Kumbhivalli hereinafter referred to as ViMEET collectively all signatories of this MoU will be known as counterparties.

1.2 Purpose

The Purpose of this MoU is to formalize a relationship between the & for mentioned institute & training agency for the purpose of cooperating in providing training & educational information & to facilitate the development of students towards industry readiness.

1.3 Objective

The objective of this MoU is to deliver On-site training on DESIGN OF MECHANICAL SYSTEMS. The students of ViMEET who have enrolled for the said program will be work on industrial live problems. These training programs for ViMEET, covers the curriculum finalized between the two organizations, copies of which with signatures of both parties are enclosed to this agreement.

1.4 Training Agency & ViMEET agree to:

1. ViMEET shall provide the infrastructure for delivering the classroom sessions & lab sessions.
2. Training agency shall provide competent trainers for theory & lab sessions. Few specific equipment's/software will also be provided by the training agency.
3. ViMEET shall provide the stay and food arrangement of the Trainer in the institute's Hostel, at the cost as per prevailing norms of the Institute. The installation of the software will be done by the Training agency on day prior to the training schedule.

It is mutually agreed and understood by all Parties that:

The Training agency shall follow the course content and Timetable will be provided by ViMEET. Refer Appendix I & II for pre-requisites and project respectively.

TRUE COPY

Vishwaniketan's (MEET, Kumbhivalli)

Page 2 of 6

2.1 **Contact Details:**

College:

Dr. B. R. Paul
Principal
Vishwaniketan's IIMET,
Kumbhivadi.

Training Agency:

Mr. Anand Bhisre,
MECHATROL ENGINEERING
SOLUTIONS, Kolhapur, PIN-416001

3.1 **3.1.1 Commencement/Expiration/Termination:**

This MoU takes effect upon the signature of the training agency & VIMET and shall remain in effect for the particular course from date of execution which will be valid for III Year (One-Year). This MOU may be extended or amended upon written request of the training agency & subsequent with concurrence of the other party. Any of the parties may terminate this MoU with 30 days written notice to the other party.

3.2 **Methodology:**

Feedback: The training agency may take feedback of the participants as & when they feel necessary. VIMET will take feedback from students on regular basis & will inform the trainers about the outcome of the feedback. The suggestions evolved out of this feedback will be MANDATORY on the part of trainers.

3.4 **Project:**

After completion of the training the training agency must provide a good quality project for each student in the group of (3-4) students and it evaluated by the Industry Experts. It is the sole responsibility of the training agency that 75% students must complete the project. After completion of training, the training agency shall provide the support for solving the problems for completion of project by skype meeting/ Email exchange/ telephonic discussion/college visit. The trainer must review the project (by physical presence at Vishwaniketan's IIMET, Khalapur Campus) at least twice in the semester (The dates will be finalized mutually agreed on).

3.5 **Examination and Certificate:**

Project Exhibition for evaluation of projects will be conducted after completion of the course delivery & project. Certificates will be provided by training agency & VIMET to all participants. The evaluation scheme will be as follows:

- 20% Marks course learning
- 30% Marks Assignment and Attendance
- 50% Marks -Project

76. Certificates and Awards.

Successful candidates will be awarded a *Certificate of Completion / Certificate* signed by VIMMET & Training Agency. The Certificate will be issued by Training Agency.

4. 4.1 Payment Disbursement

1. 30% of the total amount shall be paid to training Agency after 7 week from the date of successful completion of the basic training of each CA Job training Program.
2. 25% after the second Year of training to cover the project program of students.
3. 25% after successful completion of VNP obligation in the 1st year-04.
4. In case of unsatisfactory completion of Project, the payment done by VIMMET will be given back proportionately to each student.

Signature:

Principal,
VIMMET, Khalapur

Name: Dr. B. R. Pat



Date: 11/06/2017

Authorized signatory of Training
Agency

Name: Mr. Anand Bhas



Date: 03/06/2017

Witnesses

1. Name: Dr. S. B. Kulkarni

Sign:



2. Name: Mr. Vibhvat Aggar

Sign:



TRUE COPY

Page 4 of 6

Wp: _____ (2017)

Appendix II

Projects

S.No	Title
1	Special purpose machine
2	Bolt Counter
3	Automaton
4	Printer Modelling
5	Metaxil Handing System

TRUE COPY

HP

11/11/2023

11/11/2023

Page No. 10

CERTIFICATE OF COMPLETION

CERTIFICATE NO: MECHATROL/YIMEET/2019-20/11



MECHATOL ENGINEERING SOLUTIONS
CONFER'S TO THAT

Miss. Bawaskar Simran Sunil

HAS SUCCESSFULLY COMPLETED
ON-JOB TRAINING
ON

DESIGN OF MECHANICAL SYSTEMS

DATED FROM

July 2019 to May 2020

Mr. ANAND BHISE **MECHATOL ENGINEERING SOLUTIONS|DIRECTOR**

TRUE COPY

Vishweshwar's (YIMEET)

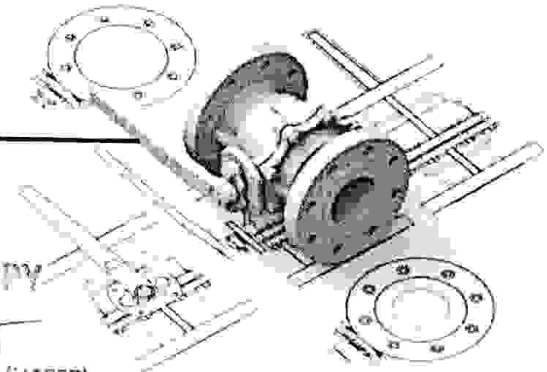

CERTIFICATE OF COMPLETION

CERTIFICATE NO: MECHATROLA/MEET/2019-20/08



MECHATOL ENGINEERING SOLUTIONS
CONFER'S TO THAT

Mr. Bhoir Shubham
HAS SUCCESSFULLY COMPLETED
ON-JOB TRAINING
ON

DESIGN OF MECHANICAL SYSTEMS
DATED FROM

July 2019 to May 2020

Mr. ANAND BHISE **MECHATOL ENGINEERING SOLUTIONS DIRECTOR**

TRUE COPY
D
Vishwadev's DIRECT

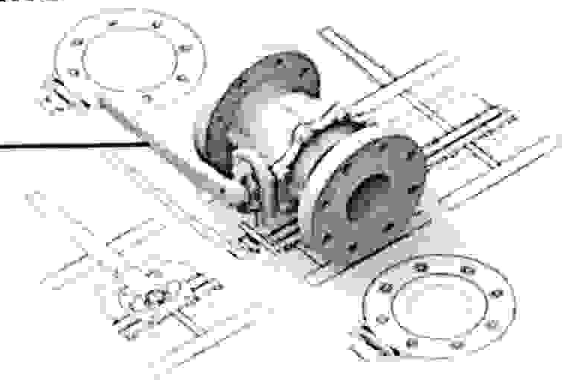

CERTIFICATE OF COMPLETION

CERTIFICATE NO: MECHATROL/VIMEET/2019-20/16



MECHATOL ENGINEERING SOLUTIONS
CONFER'S TO THAT

Mr. Chavan Sambhaji
HAS SUCCESSFULLY COMPLETED
ON-JOB TRAINING
ON

DESIGN OF MECHANICAL SYSTEMS
DATED FROM

July 2019 to May 2020

Mr. ANAND BHISE | MECHATOL ENGINEERING SOLUTIONS | DIRECTOR

TRUE COPY

(Mr. Chavan Sambhaji)

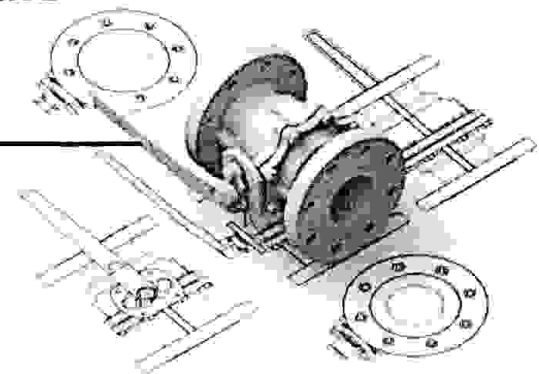

CERTIFICATE OF COMPLETION

CERTIFICATE NO: MECHATROL/VIMEET/2019-20/18



MECHATOL ENGINEERING SOLUTIONS
CONFER'S TO THAT

Mr. Deshpade Yogiraj
HAS SUCCESSFULLY COMPLETED
ON-JOB TRAINING
ON

DESIGN OF MECHANICAL SYSTEMS

DATED FROM

July 2019 to May 2020

Mr. ANAND BHISE **MECHATOL ENGINEERING SOLUTIONS** DIRECTOR

TRUE COPY

Principal
Yashwaniketan's (IMZET)

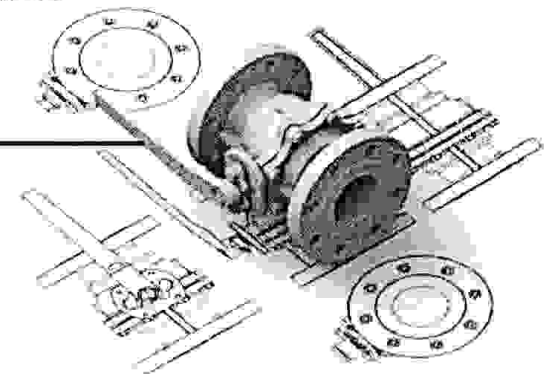

CERTIFICATE OF COMPLETION

CERTIFICATE NO: MECHATROL/VIMEET/2019-20/19



MECHATOL ENGINEERING SOLUTIONS
CONFER'S TO THAT

Mr. Gorde Prashant
HAS SUCCESSFULLY COMPLETED
ON-JOB TRAINING
ON

DESIGN OF MECHANICAL SYSTEMS

DATED FROM

July 2019 to May 2020

Mr. ANAND BHISE **MECHATOL ENGINEERING SOLUTIONS|DIRECTOR**

TRIN COPY

Project
Wishwanath's (IMEET)

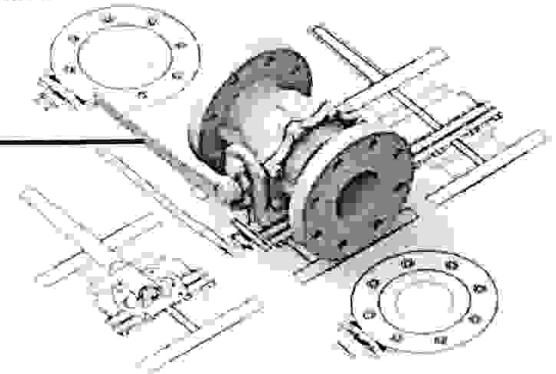



MECHATOL ENGINEERING SOLUTIONS

www.mechatolengg.co.in

CERTIFICATE OF COMPLETION

CERTIFICATE NO: MECHATROL/VIMEET/2019-20/09



MECHATOL ENGINEERING SOLUTIONS
CONFER'S TO THAT

Mr. Khedkar Pranal
HAS SUCCESSFULLY COMPLETED
ON-JOB TRAINING
ON

DESIGN OF MECHANICAL SYSTEMS

DATED FROM

July 2019 to May 2020

Mr. ANAND BHISE **MECHATOL ENGINEERING SOLUTIONS DIRECTOR**

TRUE COPY

Mr. KHEDKAR PRANAL (VIMEET)

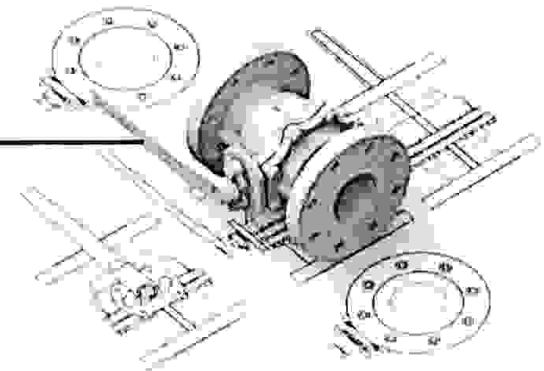



MECHATOL ENGINEERING SOLUTIONS

www.mechatolengg.co.in

CERTIFICATE OF COMPLETION

CERTIFICATE NO: MECHATROL/VIMEET/2019-20/03



MECHATOL ENGINEERING SOLUTIONS
CONFER'S TO THAT

Mr. Dhopte Vidyadhar Arunkumar

HAS SUCCESSFULLY COMPLETED
ON-JOB TRAINING
ON

DESIGN OF MECHANICAL SYSTEMS

DATED FROM

July 2019 to May 2020

Mr. ANAND BHISE **MECHATOL ENGINEERING SOLUTIONS DIRECTOR**

TRUE COPY
Principal
Vishwanathar's (IMEET)

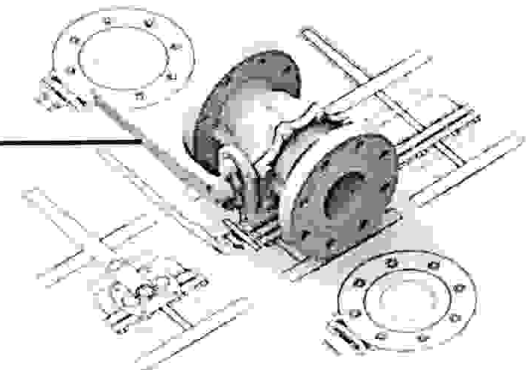

CERTIFICATE OF COMPLETION

CERTIFICATE NO: MECHATROL/VIMEET/2029-20/05



MECHATOL ENGINEERING SOLUTIONS
CONFER'S TO THAT

Mr. Mali Rushikesh Ravindra
HAS SUCCESSFULLY COMPLETED
ON-JOB TRAINING
ON

DESIGN OF MECHANICAL SYSTEMS
DATED FROM

July 2019 to May 2020

Mr. ANAND BHISE **MECHATOL ENGINEERING SOLUTIONS** DIRECTOR

TRUE COPY
9/1/20
Vishwanikar's (IMEET)

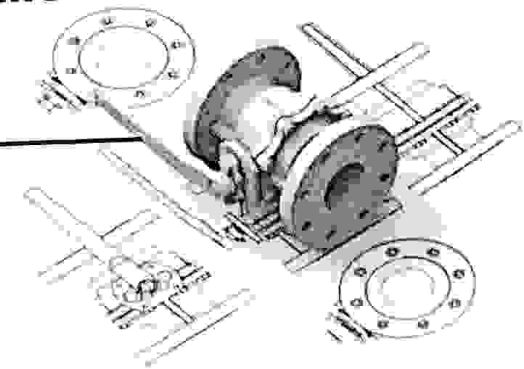

CERTIFICATE OF COMPLETION

CERTIFICATE NO: MECHATROLVIMEET/2019-2020/6



MECHATOL ENGINEERING SOLUTIONS
CONFER'S TO THAT

Miss. Malusare Sneha
HAS SUCCESSFULLY COMPLETED
ON-JOB TRAINING
ON

DESIGN OF MECHANICAL SYSTEMS
DATED FROM

July 2019 to May 2020

Mr. ANAND BHISE **MECHATOL ENGINEERING SOLUTIONS** DIRECTOR

TRUE COPY
Principal
Vishwanathar's (IMEET)

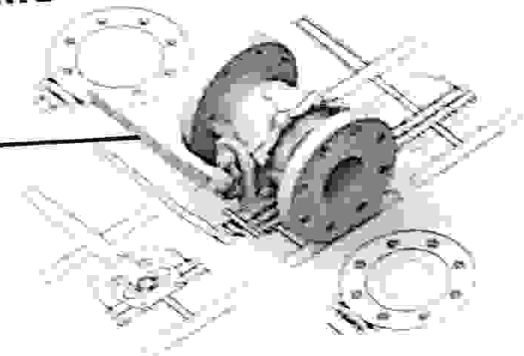

CERTIFICATE OF COMPLETION

CERTIFICATE NO: MECHATROL/VIMEET/2019-20/02



MECHATOL ENGINEERING SOLUTIONS
CONFER'S TO THAT

Mr. Mandhare Pratik Pramod
HAS SUCCESSFULLY COMPLETED
ON-JOB TRAINING
ON

DESIGN OF MECHANICAL SYSTEMS
DATED FROM

July 2019 to May 2020

Mr. ANAND BHISE **MECHATOL ENGINEERING SOLUTIONS DIRECTOR**

TRUE COPY
Pratik
Mandhare's (VIMEET)

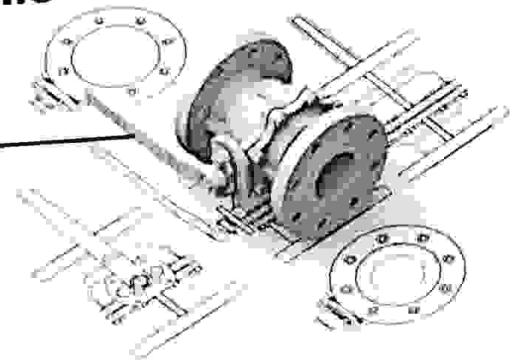

CERTIFICATE OF COMPLETION

CERTIFICATE NO: MECHATROL/VIMEET/2029-20/15



MECHATOL ENGINEERING SOLUTIONS
CONFER'S TO THAT

Mr. Mayekar Pratik
HAS SUCCESSFULLY COMPLETED
ON-JOB TRAINING
ON

DESIGN OF MECHANICAL SYSTEMS
DATED FROM

July 2019 to May 2020

Mr. ANAND BHISE **MECHATOL ENGINEERING SOLUTIONS** DIRECTOR

TRUE COPY
H
Vishwajit's (VIMEET)

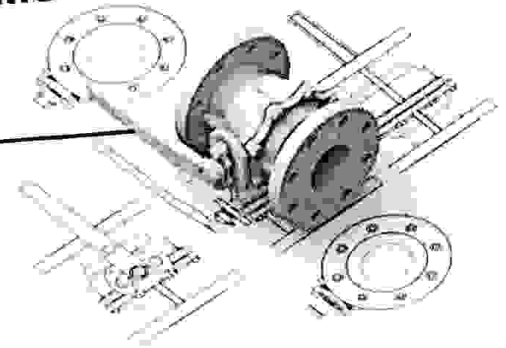

CERTIFICATE OF COMPLETION

CERTIFICATE NO: MECHATROL/VIMEET/2019-20/07



MECHATOL ENGINEERING SOLUTIONS
CONFER'S TO THAT

Mr. Mondkar Sandeep
HAS SUCCESSFULLY COMPLETED
ON-JOB TRAINING
ON

DESIGN OF MECHANICAL SYSTEMS
DATED FROM

July 2019 to May 2020

Mr. ANAND BHISE **MECHATOL ENGINEERING SOLUTIONS** DIRECTOR

TRUE COPY
of
Vishwakarma's (VIMEET)

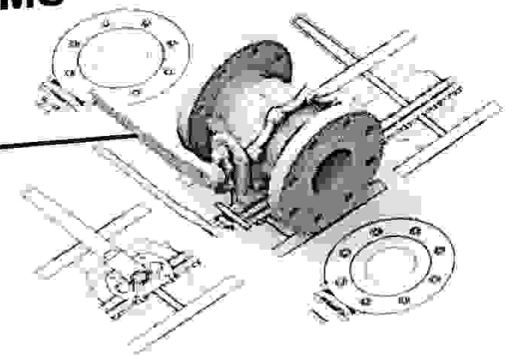

CERTIFICATE OF COMPLETION

CERTIFICATE NO: MECHATROL/VIMEET/2019-20/010



MECHATOL ENGINEERING SOLUTIONS
CONFER'S TO THAT

Miss. Naikwade Mithlesha Motilal
HAS SUCCESSFULLY COMPLETED
ON-JOB TRAINING
ON

DESIGN OF MECHANICAL SYSTEMS
DATED FROM

July 2019 to May 2020

Mr. ANAND BHISE **MECHATOL ENGINEERING SOLUTIONS DIRECTOR**

TRC
HP
(11/11/2020)

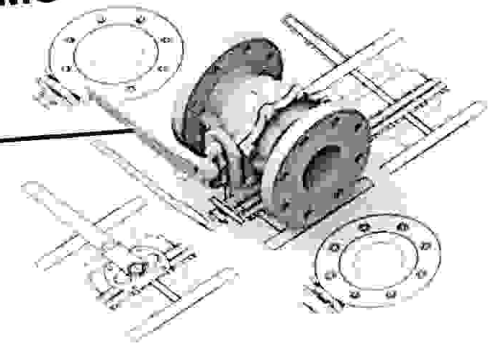

CERTIFICATE OF COMPLETION

CERTIFICATE NO: MECHATROL/VIMEET/2019-20/17



MECHATOL ENGINEERING SOLUTIONS
CONFER'S TO THAT

Mr. Sawant Bhushan
HAS SUCCESSFULLY COMPLETED
ON-JOB TRAINING
ON

DESIGN OF MECHANICAL SYSTEMS
DATED FROM

July 2019 to May 2020

Mr. ANAND BHISE **MECHATOL ENGINEERING SOLUTIONS** DIRECTOR

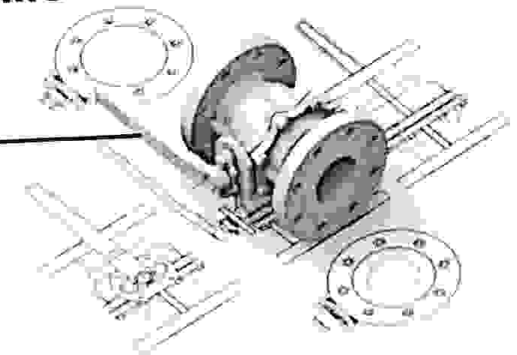

CERTIFICATE OF COMPLETION

CERTIFICATE NO: MECHATROL/VIMEET/2029-20/21



MECHATOL ENGINEERING SOLUTIONS
CONFER'S TO THAT

Mr. Shinde Mayur
HAS SUCCESSFULLY COMPLETED
ON-JOB TRAINING
ON

DESIGN OF MECHANICAL SYSTEMS
DATED FROM

July 2019 to May 2020

Mr. ANAND BHISE MECHATOL ENGINEERING SOLUTIONS DIRECTOR

TRUE COPY
[Signature]
MECHATROL ENGINEERING SOLUTIONS (VIMEET)

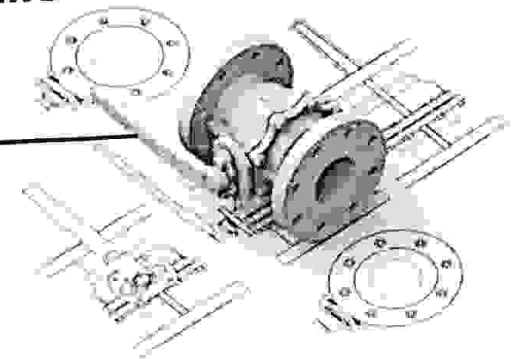

CERTIFICATE OF COMPLETION

CERTIFICATE NO: MECHATROL/VIMEET/2029-20/01



MECHATOL ENGINEERING SOLUTIONS
CONFER'S TO THAT

Mr. Shinde Yash Deepak
HAS SUCCESSFULLY COMPLETED
ON-JOB TRAINING
ON

DESIGN OF MECHANICAL SYSTEMS
DATED FROM

July 2019 to May 2020

Mr. ANAND BHISE **MECHATOL ENGINEERING SOLUTIONS DIRECTOR**

THIS COPY
IS VALID

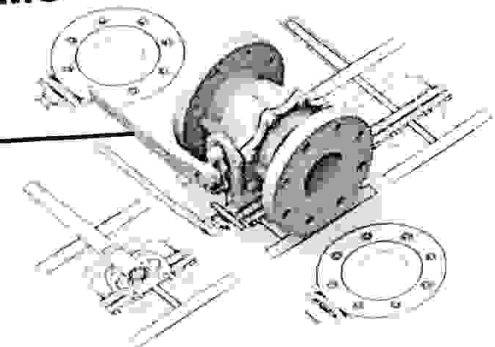

CERTIFICATE OF COMPLETION

CERTIFICATE NO: MECHATROL/VINEET/2019-20/04



MECHATOL ENGINEERING SOLUTIONS
CONFER'S TO THAT

Mr. Shukla Abhishek Dineshkumar
HAS SUCCESSFULLY COMPLETED
ON-JOB TRAINING
ON

DESIGN OF MECHANICAL SYSTEMS
DATED FROM

July 2019 to May 2020

Mr. ANAND BHISE **MECHATOL ENGINEERING SOLUTIONS** DIRECTOR

TRUE COPY

VINEET (VINEET)

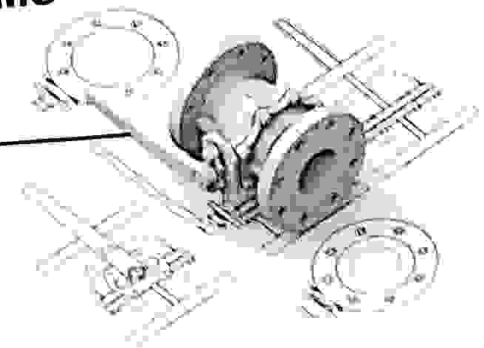

CERTIFICATE OF COMPLETION

CERTIFICATE NO: MECHATROL/VIMEET/2029-20/20



MECHATOL ENGINEERING SOLUTIONS
CONFER'S TO THAT

Mr. Tembare Pritam
HAS SUCCESSFULLY COMPLETED
ON-JOB TRAINING
ON

DESIGN OF MECHANICAL SYSTEMS
DATED FROM

July 2019 to May 2020

Mr. ANAND BHISE MECHATOL ENGINEERING SOLUTIONS DIRECTOR

TRUE COPY

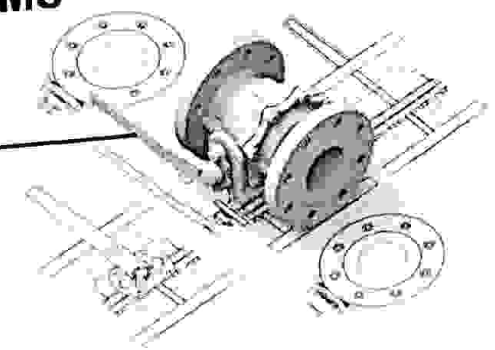

CERTIFICATE OF COMPLETION

CERTIFICATE NO: MECHATROL/VIMEET/2019-20/14



MECHATOL ENGINEERING SOLUTIONS
CONFER'S TO THAT

Mr. Thale Sanket
HAS SUCCESSFULLY COMPLETED
ON-JOB TRAINING
ON

DESIGN OF MECHANICAL SYSTEMS
DATED FROM

July 2019 to May 2020

Mr. ANAND BHISE MECHATOL ENGINEERING SOLUTIONS/DIRECTOR

TRUE COPY
H
2 (VIMEET)

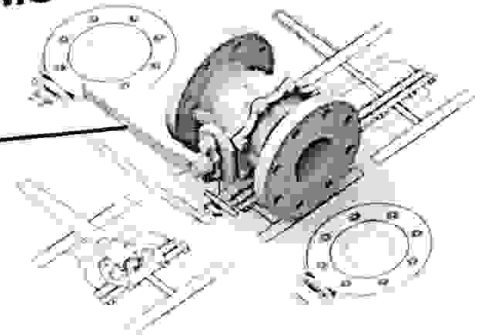

CERTIFICATE OF COMPLETION

CERTIFICATE NO: MECHATROL/VIMEET/2019-20/13



MECHATOL ENGINEERING SOLUTIONS
CONFER'S TO THAT

Mr. Vedak Harsh

HAS SUCCESSFULLY COMPLETED
ON-JOB TRAINING
ON

DESIGN OF MECHANICAL SYSTEMS

DATED FROM

July 2019 to May 2020

Mr. ANAND BHISE **MECHATOL ENGINEERING SOLUTIONS/DIRECTOR**

TRUE COPY

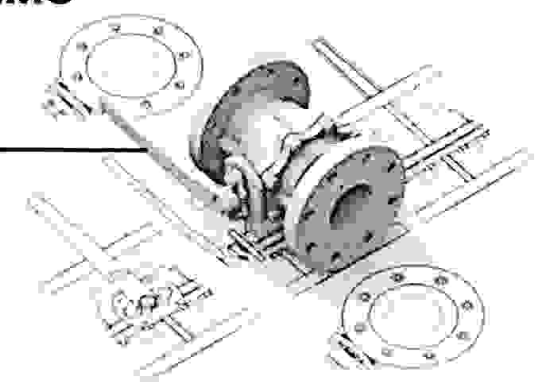

CERTIFICATE OF COMPLETION

CERTIFICATE NO: MECHATROL/VIMEET/2018-19/14



MECHATOL ENGINEERING SOLUTIONS
CONFER'S TO THAT

Mr. BARSHI ASHISH NARAYAN
HAS SUCCESSFULLY COMPLETED
ON-JOB TRAINING
ON

DESIGN OF MECHANICAL SYSTEMS
DATED FROM

July 2018 to May 2019

Mr. ANAND BHISE **MECHATOL ENGINEERING SOLUTIONS** DIRECTOR

TRUE COPY
19/05/2019
Vishwajit Bhise (VIMEET)

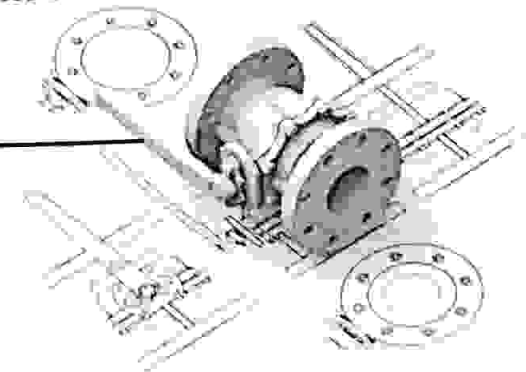



MECHATOL ENGINEERING SOLUTIONS

www.mechatolengg.co.in

CERTIFICATE OF COMPLETION

CERTIFICATE NO: MECHATROL/VIME/ET/2018-19/13



MECHATOL ENGINEERING SOLUTIONS
CONFER'S TO THAT

Mr. DHAYAL SHREEKUMAR RATANLAL

HAS SUCCESSFULLY COMPLETED
ON-JOB TRAINING
ON

DESIGN OF MECHANICAL SYSTEMS

DATED FROM

July 2018 to May 2019

Mr. ANAND BHISE **MECHATOL ENGINEERING SOLUTIONS DIRECTOR**

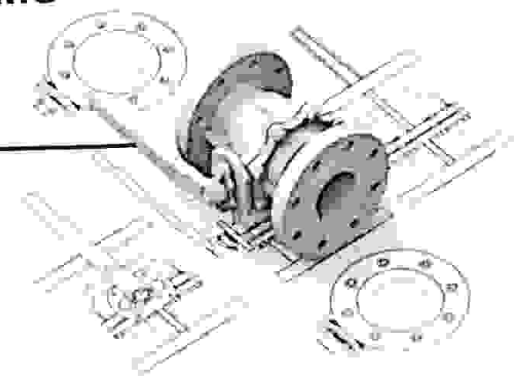

CERTIFICATE OF COMPLETION

CERTIFICATE NO: MECHATROL/VIMEET/2018-19/11



MECHATOL ENGINEERING SOLUTIONS
CONFER'S TO THAT

Mr. DHURE SAURABH VISHNU
HAS SUCCESSFULLY COMPLETED
ON-JOB TRAINING
ON

DESIGN OF MECHANICAL SYSTEMS
DATED FROM

July 2018 to May 2019

Mr. ANAND BHISE MECHATOL ENGINEERING SOLUTIONS DIRECTOR

TRUE COPY
Vishnu Saurabh's (VIMEET)

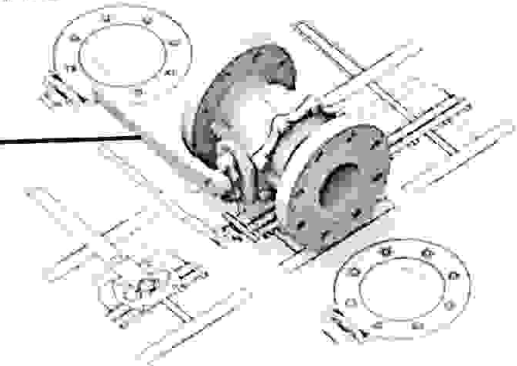



MECHATOL ENGINEERING SOLUTIONS

www.mechatolengg.co.in

CERTIFICATE OF COMPLETION

CERTIFICATE NO: MECHATROL-VIMEET/2018-19/03



MECHATOL ENGINEERING SOLUTIONS
CONFER'S TO THAT

Mr. GAIKAR SUMEET MANOHAR

HAS SUCCESSFULLY COMPLETED
ON-JOB TRAINING
ON

DESIGN OF MECHANICAL SYSTEMS

DATED FROM

July 2018 to May 2019

Mr. ANAND BHISE **MECHATOL ENGINEERING SOLUTIONS DIRECTOR**

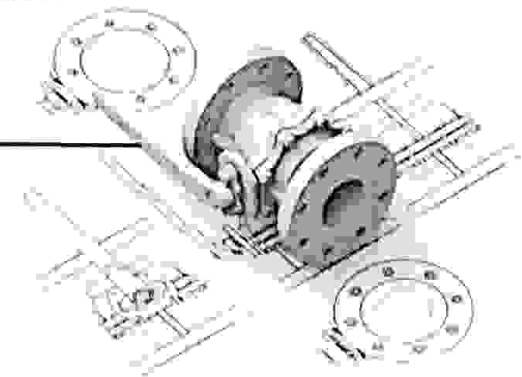

M ECHATOL ENGINEERING SOLUTIONS

www.mechatolengg.co.in

CERTIFICATE OF COMPLETION

CERTIFICATE NO: MECHATROL/VIMEET/2018-19/06



MECHATOL ENGINEERING SOLUTIONS
CONFER'S TO THAT

Mr. GAIKWAD SANGRAM SHIVAJI

HAS SUCCESSFULLY COMPLETED
ON-JOB TRAINING
ON

DESIGN OF MECHANICAL SYSTEMS

DATED FROM

July 2018 to May 2019

Mr. ANAND BHISE **MECHATOL ENGINEERING SOLUTIONS DIRECTOR**

TRUE COPY

Witness (Director)

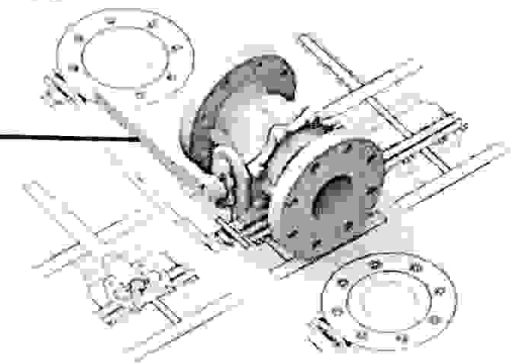

M ECHATOL ENGINEERING SOLUTIONS

www.mechatolengg.co.in

CERTIFICATE OF COMPLETION

CERTIFICATE NO: MECHATROL/VIMEET/2018-19/01



MECHATOL ENGINEERING SOLUTIONS
CONFER'S TO THAT

Mr. GAJARE ROHAN LAXMAN

HAS SUCCESSFULLY COMPLETED
ON-JOB TRAINING
ON

DESIGN OF MECHANICAL SYSTEMS

DATED FROM

July 2018 to May 2019

Mr. ANAND BHISE **MECHATOL ENGINEERING SOLUTIONS** DIRECTOR

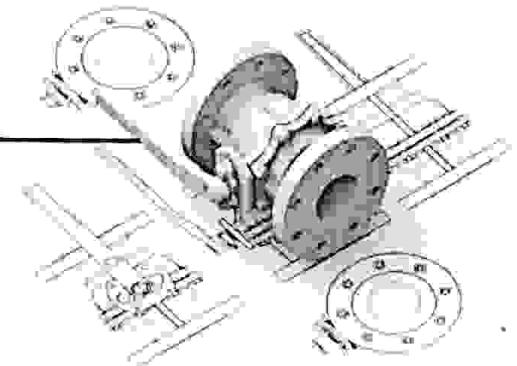

CERTIFICATE OF COMPLETION

CERTIFICATE NO: MECHATROL/VIMEET/2018-19/02



MECHATOL ENGINEERING SOLUTIONS
CONFER'S TO THAT

Mr. GAWALI VILAS ARJUN

HAS SUCCESSFULLY COMPLETED
ON-JOB TRAINING
ON

DESIGN OF MECHANICAL SYSTEMS

DATED FROM

July 2018 to May 2019

Mr. ANAND BHISE **MECHATOL ENGINEERING SOLUTIONS DIRECTOR**

TRUE COPY

H
-S (VIMEET)

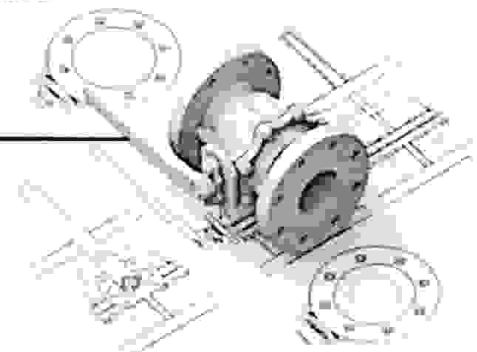

CERTIFICATE OF COMPLETION

CERTIFICATE NO: MECHATROL/VIMLET 2018-19-12



MECHATOL ENGINEERING SOLUTIONS
CONFER'S TO THAT

Mr. HEGDE SUMANTH SURESH

HAS SUCCESSFULLY COMPLETED
ON-JOB TRAINING
ON

DESIGN OF MECHANICAL SYSTEMS

DATED FROM

July 2018 to May 2019

Mr. ANAND BHISE **MECHATOL ENGINEERING SOLUTIONS DIRECTOR**

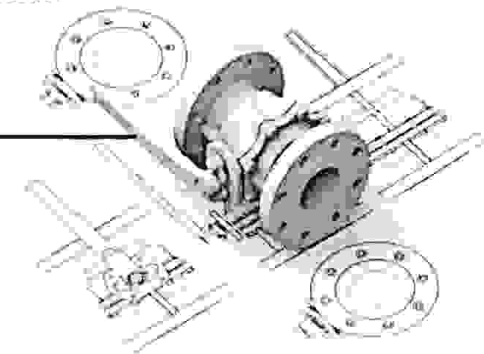

CERTIFICATE OF COMPLETION

CERTIFICATE NO: MECHATROL/VIMEET/2018-19/10



MECHATOL ENGINEERING SOLUTIONS
CONFER'S TO THAT

Mr. JANGAM ANIKET SUHAS

HAS SUCCESSFULLY COMPLETED
ON-JOB TRAINING
ON

DESIGN OF MECHANICAL SYSTEMS

DATED FROM

July 2018 to May 2019

Mr. ANAND BHISE **MECHATOL ENGINEERING SOLUTIONS DIRECTOR**

TRUE COPY
Vishwanath's (VIMEET)

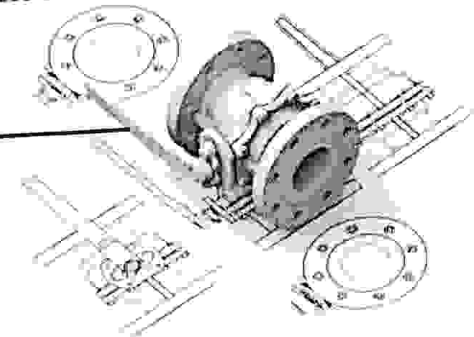

CERTIFICATE OF COMPLETION

CERTIFICATE NO- MECHATROL-VIMHBT 2018-1909



MECHATOL ENGINEERING SOLUTIONS
CONFER'S TO THAT

Mr. KAMBLE PRANIL DNYANESHWAR

HAS SUCCESSFULLY COMPLETED
ON-JOB TRAINING
ON

DESIGN OF MECHANICAL SYSTEMS

DATED FROM

July 2018 to May 2019

Mr. ANAND BHISE MECHATOL ENGINEERING SOLUTIONS DIRECTOR

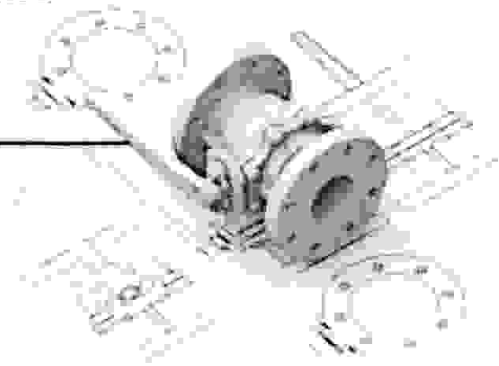

CERTIFICATE NO: MECHATROLVIMEET 2018-19 07

CERTIFICATE OF COMPLETION



MECHATOL ENGINEERING SOLUTIONS
CONFER'S TO THAT

Mr. LOKHANDE DHANANJAY DEVIDAS
HAS SUCCESSFULLY COMPLETED
ON-JOB TRAINING
ON

DESIGN OF MECHANICAL SYSTEMS
DATED FROM

July 2018 to May 2019

Mr. ANAND BHISE **MECHATOL ENGINEERING SOLUTIONS DIRECTOR**

TRUE COPY
Vishwanath

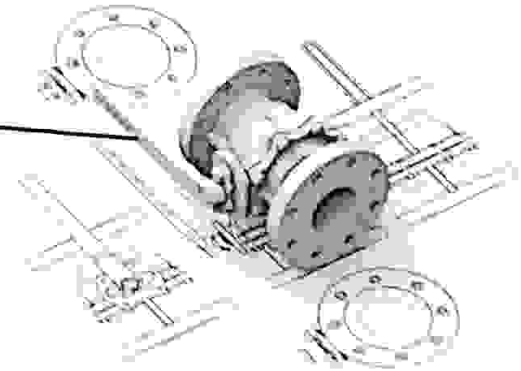

CERTIFICATE OF COMPLETION

CERTIFICATE NO: MECHATROL/VIMEET/2018-19/15



MECHATOL ENGINEERING SOLUTIONS
CONFER'S TO THAT

Mr. PATIL OMKAR BHASKAR
HAS SUCCESSFULLY COMPLETED
ON-JOB TRAINING
ON

DESIGN OF MECHANICAL SYSTEMS
DATED FROM

July 2018 to May 2019

Mr. ANAND BHISE **MECHATOL ENGINEERING SOLUTIONS|DIRECTOR**

TRUE COPY
Patil Omkar S (VIMEET)

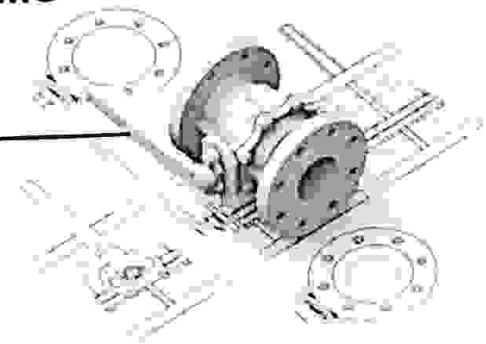

CERTIFICATE OF COMPLETION

CERTIFICATE NO: MECHATROL/VIMEET/2018-19/08



MECHATOL ENGINEERING SOLUTIONS
CONFER'S TO THAT

Mr. PATIL SANKET RAMESH
HAS SUCCESSFULLY COMPLETED
ON-JOB TRAINING
ON

DESIGN OF MECHANICAL SYSTEMS
DATED FROM

July 2018 to May 2019

Mr. ANAND BHISE **MECHATOL ENGINEERING SOLUTIONS/DIRECTOR**

TRUE COPY
H
KAMAL KUMAR'S (SWEET)

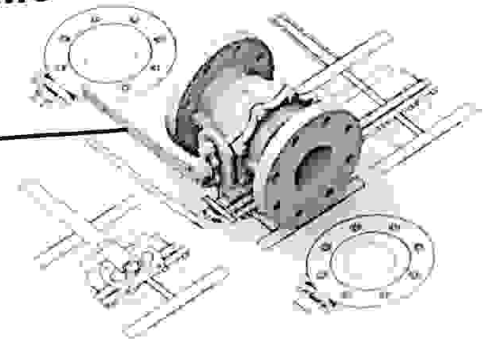



MECHATOL ENGINEERING SOLUTIONS

www.mechatolengg.co.in

CERTIFICATE OF COMPLETION

CERTIFICATE NO: MECHATROL/VIMEET/2018-19-04



MECHATOL ENGINEERING SOLUTIONS
CONFER'S TO THAT

Mr. PHADTARE SANKET SANJAY

HAS SUCCESSFULLY COMPLETED
ON-JOB TRAINING
ON

DESIGN OF MECHANICAL SYSTEMS

DATED FROM

July 2018 to May 2019

Mr. ANAND BHISE **MECHATOL ENGINEERING SOLUTIONS** DIRECTOR

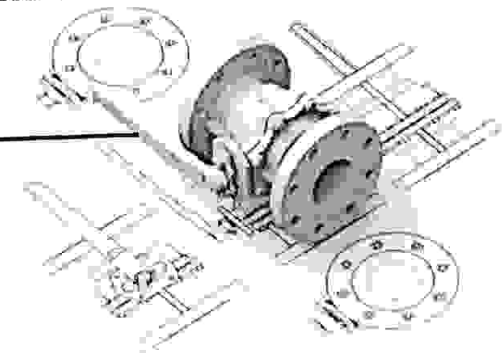



MECHATOL ENGINEERING SOLUTIONS
www.mechatolengg.co.in

CERTIFICATE OF COMPLETION

CERTIFICATE NO: MECHATOL/VIMEET/2018-19/05



MECHATOL ENGINEERING SOLUTIONS
CONFER'S TO THAT

Mr. RASAL TEJESH SATISH

HAS SUCCESSFULLY COMPLETED
ON-JOB TRAINING
ON

DESIGN OF MECHANICAL SYSTEMS
DATED FROM

July 2018 to May 2019

Mr. ANAND BHISE **MECHATOL ENGINEERING SOLUTIONS DIRECTOR**

TEJESH SATISH
3/5/19

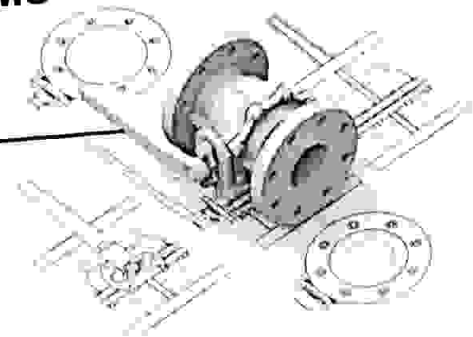

CERTIFICATE OF COMPLETION

CERTIFICATE NO: MECHATOL/VIMEET/2018-19/20



MECHATOL ENGINEERING SOLUTIONS
CONFER'S TO THAT

Mr. SALUNKE HRUSHIKESH BHARATBHUSHAN

HAS SUCCESSFULLY COMPLETED
ON-JOB TRAINING
ON

DESIGN OF MECHANICAL SYSTEMS

DATED FROM

July 2018 to May 2019

Mr. ANAND BHISE **MECHATOL ENGINEERING SOLUTIONS DIRECTOR**

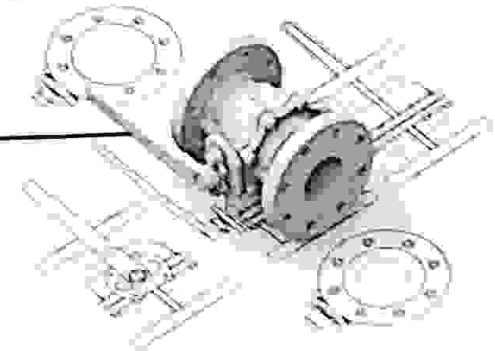

CERTIFICATE OF COMPLETION

CERTIFICATE NO: MECHATROL/VIMEET/2018-19/18



MECHATOL ENGINEERING SOLUTIONS
CONFER'S TO THAT

Mr. SHAIKH SAHEB MOIN
HAS SUCCESSFULLY COMPLETED
ON-JOB TRAINING
ON

DESIGN OF MECHANICAL SYSTEMS
DATED FROM

July 2018 to May 2019

Mr. ANAND BHISE **MECHATOL ENGINEERING SOLUTIONS DIRECTOR**

TRUE COPY
D
Mr. Anand Bhise (VIMEET)

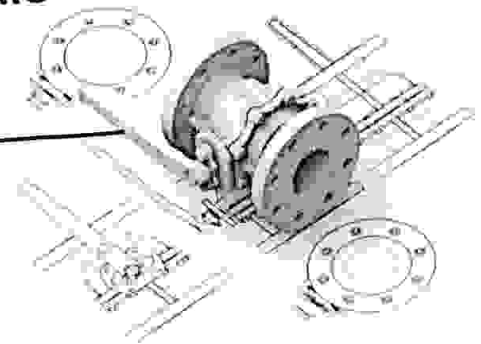

CERTIFICATE OF COMPLETION

CERTIFICATE NO: MECHATROL/VJMEET/2018-19/23



MECHATOL ENGINEERING SOLUTIONS
CONFER'S TO THAT

Mr. SHIVTHARE ABHISHEK ROHIDAS

HAS SUCCESSFULLY COMPLETED
ON-JOB TRAINING
ON

DESIGN OF MECHANICAL SYSTEMS

DATED FROM

July 2018 to May 2019

Mr. ANAND BHISE **MECHATOL ENGINEERING SOLUTIONS DIRECTOR**

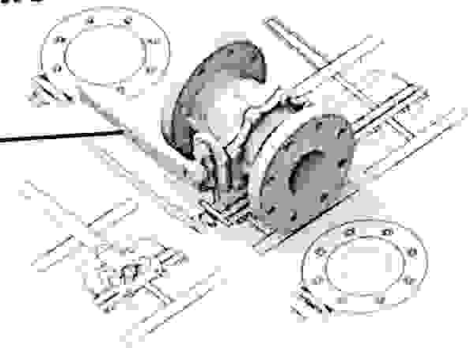

CERTIFICATE OF COMPLETION

CERTIFICATE NO: MECHATROL/VIMEET/2018-19/16



MECHATOL ENGINEERING SOLUTIONS
CONFER'S TO THAT

Mr. SINGH KARANPREET RAJINDERSINGH
HAS SUCCESSFULLY COMPLETED
ON-JOB TRAINING
ON

DESIGN OF MECHANICAL SYSTEMS
DATED FROM

July 2018 to May 2019

Mr. ANAND BHISE **MECHATOL ENGINEERING SOLUTIONS DIRECTOR**

TRUE COPY

VIVEK S. BHISE (VIMEET)

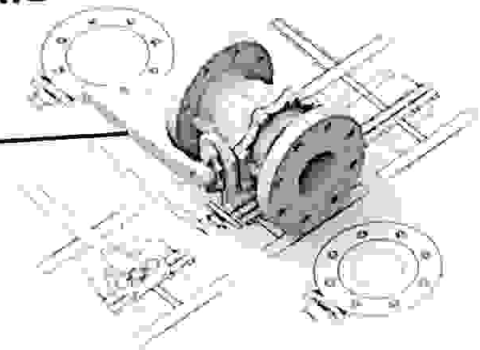



MECHATOL ENGINEERING SOLUTIONS

www.mechatolengg.co.in

CERTIFICATE OF COMPLETION

CERTIFICATE NO: MECHATROL/VIMEET/2018-19/17



MECHATOL ENGINEERING SOLUTIONS
CONFER'S TO THAT

Mr. YADAV SUDHIRKUMAR RAMSHARAN

HAS SUCCESSFULLY COMPLETED
ON-JOB TRAINING
ON

DESIGN OF MECHANICAL SYSTEMS

DATED FROM

July 2018 to May 2019

Mr. ANAND BHISE **MECHATOL ENGINEERING SOLUTIONS** DIRECTOR

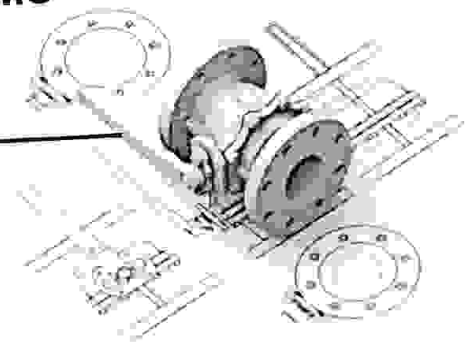

CERTIFICATE OF COMPLETION

CERTIFICATE NO: MECHATROL/NIMEET/2020-21/25



MECHATOL ENGINEERING SOLUTIONS
CONFER'S TO THAT

Mr. Babre Tushar Ganesh
HAS SUCCESSFULLY COMPLETED
ON-JOB TRAINING
ON

DESIGN OF MECHANICAL SYSTEMS
DATED FROM

July 2020 to May 2021

Mr. ANAND BHISE MECHATOL ENGINEERING SOLUTIONS DIRECTOR

TRUE COPY

Mr. Babre Tushar Ganesh (NIMEET)

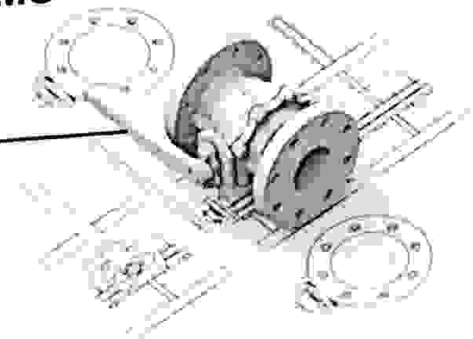



MECHATOL ENGINEERING SOLUTIONS
www.mechatolengg.co.in

CERTIFICATE OF COMPLETION

CERTIFICATE NO: MECHATROL/VIMEET/2020-21/26



MECHATOL ENGINEERING SOLUTIONS
CONFER'S TO THAT

Mr. Badgujar Nachiket Yuvraj
HAS SUCCESSFULLY COMPLETED
ON-JOB TRAINING
ON

DESIGN OF MECHANICAL SYSTEMS
DATED FROM

July 2020 to May 2021

Mr. ANAND BHISE **MECHATOL ENGINEERING SOLUTIONS** DIRECTOR

TRUE COPY
21/5
VET. CERT. BNG (DMS)

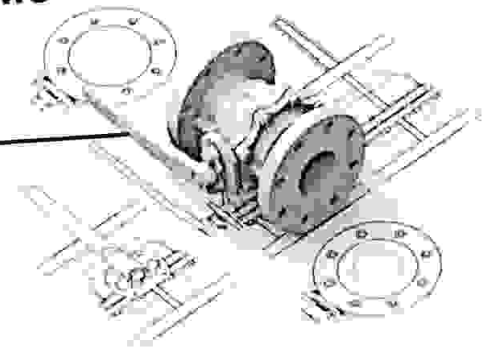



MECHATOL ENGINEERING SOLUTIONS

www.mechatolengg.co.in

CERTIFICATE OF COMPLETION

CERTIFICATE NO: MECHATOL/WIMEET/2020-21/27



MECHATOL ENGINEERING SOLUTIONS
CONFER'S TO THAT

Mr. Chavan Omkar Tatoo

HAS SUCCESSFULLY COMPLETED
ON-JOB TRAINING
ON

DESIGN OF MECHANICAL SYSTEMS

DATED FROM

July 2020 to May 2021

Mr. ANAND BHISE **MECHATOL ENGINEERING SOLUTIONS DIRECTOR**

TRUE COPY
[Signature]
Director of Mechatol (WIMEET)

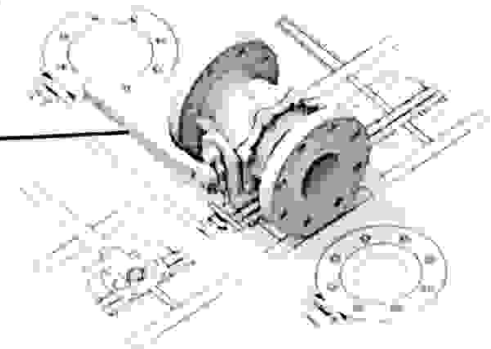

CERTIFICATE OF COMPLETION

CERTIFICATE NO: MECHATROLVIMEET/2020-21/04



MECHATOL ENGINEERING SOLUTIONS
CONFER'S TO THAT

Mr. Choraghe Manoj Maruti

HAS SUCCESSFULLY COMPLETED
ON-JOB TRAINING
ON

DESIGN OF MECHANICAL SYSTEMS

DATED FROM

July 2020 to May 2021

Mr. ANAND BHISE **MECHATOL ENGINEERING SOLUTIONS** DIRECTOR

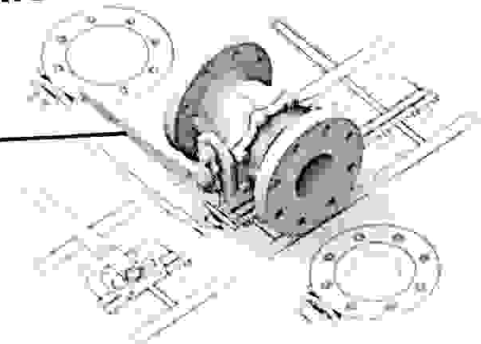

CERTIFICATE OF COMPLETION

CERTIFICATE NO: MECHATROL/VIMEET/2020-21/24



MECHATOL ENGINEERING SOLUTIONS
CONFER'S TO THAT

Mr. Dnyaneshwar Datta Waghmare

HAS SUCCESSFULLY COMPLETED
ON-JOB TRAINING
ON

DESIGN OF MECHANICAL SYSTEMS

DATED FROM

July 2020 to May 2021

Mr. ANAND BHISE **MECHATOL ENGINEERING SOLUTIONS** DIRECTOR

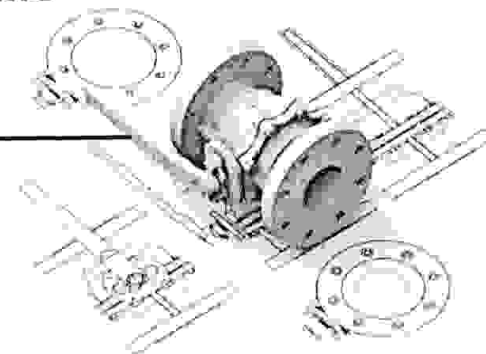



MECHATOL ENGINEERING SOLUTIONS

www.mechatolengg.co.in

CERTIFICATE OF COMPLETION

CERTIFICATE NO: MECHATROL/VIMEET/2020-21-03



MECHATOL ENGINEERING SOLUTIONS
CONFER'S TO THAT

Mr. Gaikwad Sachin Maruti

HAS SUCCESSFULLY COMPLETED
ON-JOB TRAINING
ON

DESIGN OF MECHANICAL SYSTEMS

DATED FROM

July 2020 to May 2021

Mr. ANAND BHISE **MECHATOL ENGINEERING SOLUTIONS DIRECTOR**

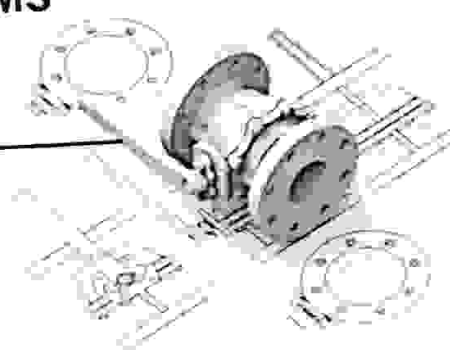



MECHATOL ENGINEERING SOLUTIONS

www.mechatolengg.co.in

CERTIFICATE OF COMPLETION

CERTIFICATE NO: MECHATROLVIMBET 2020-21/13



MECHATOL ENGINEERING SOLUTIONS
CONFER'S TO THAT

Mr. Hardik Pradeep Shah

HAS SUCCESSFULLY COMPLETED
ON-JOB TRAINING
ON

DESIGN OF MECHANICAL SYSTEMS

DATED FROM

July 2020 to May 2021

Mr. ANAND BHISE **MECHATOL ENGINEERING SOLUTIONS DIRECTOR**

TRUE COPY
Vishwanath (MECT)

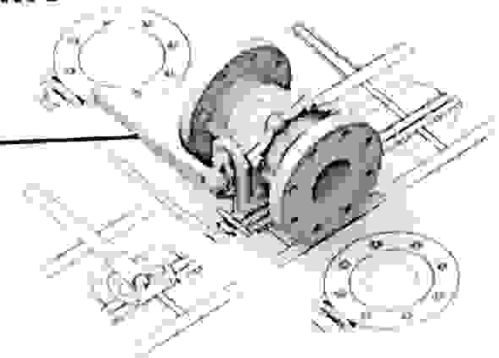

CERTIFICATE OF COMPLETION

CERTIFICATE NO: MECHATROL/VIMEET/2020-21/01



MECHATOL ENGINEERING SOLUTIONS
CONFER'S TO THAT

Mr. Hrushikesh Milind bhavsar
HAS SUCCESSFULLY COMPLETED
ON-JOB TRAINING
ON

DESIGN OF MECHANICAL SYSTEMS
DATED FROM

July 2020 to May 2021

Mr. ANAND BHISE **MECHATOL ENGINEERING SOLUTIONS** DIRECTOR

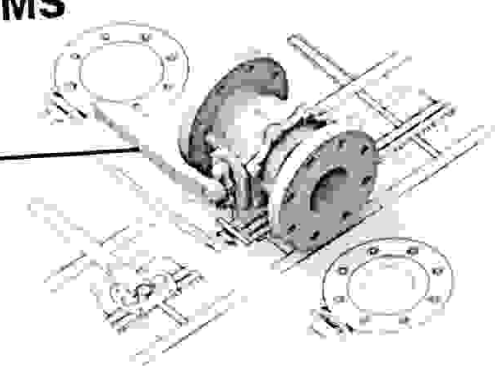

CERTIFICATE OF COMPLETION

CERTIFICATE NO: MECHATROL/VIMEET/2020-21/12



MECHATOL ENGINEERING SOLUTIONS
CONFER'S TO THAT

Mr. Manas Yogesh Godbole

HAS SUCCESSFULLY COMPLETED
ON-JOB TRAINING
ON

DESIGN OF MECHANICAL SYSTEMS

DATED FROM

July 2020 to May 2021

Mr. ANAND BHISE | MECHATOL ENGINEERING SOLUTIONS | DIRECTOR

TRUE COPY
Principal
Vishwanthkaran's (VIMEET)

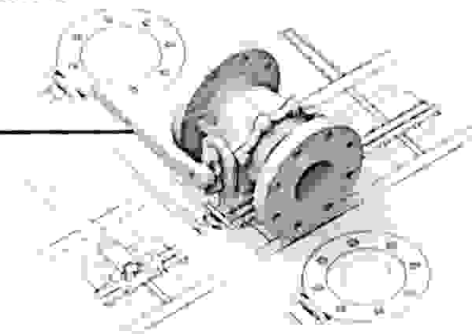

CERTIFICATE OF COMPLETION

CERTIFICATE NO: MECHATROLVIMEET/2020-21/22



MECHATOL ENGINEERING SOLUTIONS
CONFER'S TO THAT

Mr. Mandeep Singh Vihal
HAS SUCCESSFULLY COMPLETED
ON-JOB TRAINING
ON

DESIGN OF MECHANICAL SYSTEMS

DATED FROM

July 2020 to May 2021

Mr ANAND BHISE MECHATOL ENGINEERING SOLUTIONS DIRECTOR

TRUE COPY
Mr. Mandeep Singh Vihal (VIMEET)

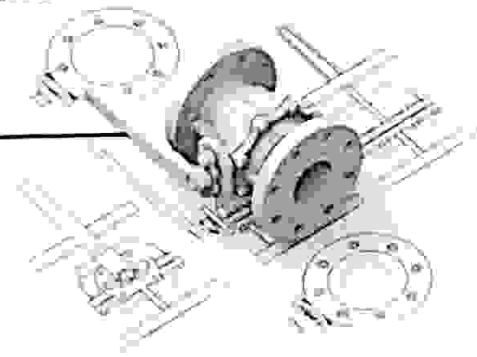

CERTIFICATE OF COMPLETION

CERTIFICATE NO: MECHATROL VIMEET 2020-21, 18



MECHATOL ENGINEERING SOLUTIONS
CONFER'S TO THAT

Mr. Mhase Roshan Ganesh

HAS SUCCESSFULLY COMPLETED
ON-JOB TRAINING
ON

DESIGN OF MECHANICAL SYSTEMS

DATED FROM

July 2020 to May 2021

Mr. ANAND BHISE **MECHATOL ENGINEERING SOLUTIONS DIRECTOR**

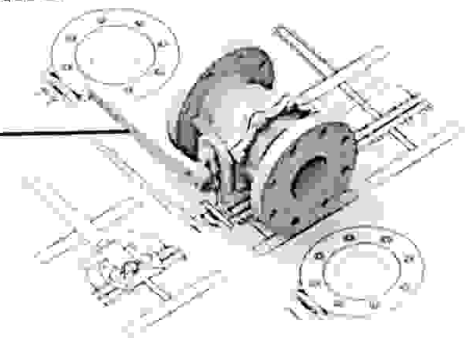



MECHATOL ENGINEERING SOLUTIONS

www.mechatolengg.co.in

CERTIFICATE OF COMPLETION

CERTIFICATE NO: MECHATROL/VIMEET/2020-21/03



MECHATOL ENGINEERING SOLUTIONS
CONFER'S TO THAT

Mr. PATIL SAHIL VIVEK

HAS SUCCESSFULLY COMPLETED
ON-JOB TRAINING
ON

DESIGN OF MECHANICAL SYSTEMS

DATED FROM

July 2020 to May 2021

Mr. ANAND BHISE **MECHATOL ENGINEERING SOLUTIONS DIRECTOR**

TRUE COPY
MECHATOL ENGINEERING SOLUTIONS
PUNE

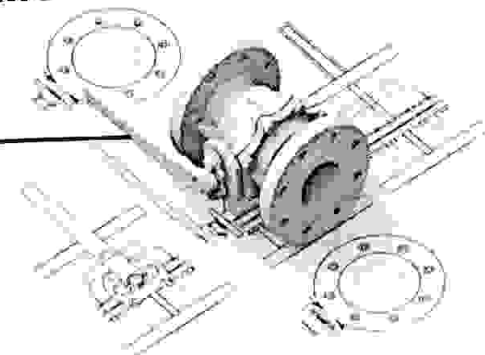

MECHATOL ENGINEERING SOLUTIONS

www.mechatolengg.co.in

CERTIFICATE OF COMPLETION

CERTIFICATE NO: MECHATROL/VIMEET/2020-21/14



MECHATOL ENGINEERING SOLUTIONS
CONFER'S TO THAT

Mr. Prathamesh Santosh Jadhav

HAS SUCCESSFULLY COMPLETED
ON-JOB TRAINING
ON

DESIGN OF MECHANICAL SYSTEMS

DATED FROM

July 2020 to May 2021

Mr. ANAND BHISE **MECHATOL ENGINEERING SOLUTIONS** DIRECTOR

TRUE COPY
of
Certificate
of Completion (VIMEET)

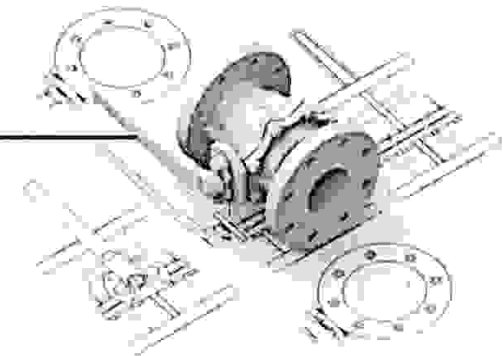

CERTIFICATE OF COMPLETION

CERTIFICATE NO: MECHATROL/VIMEET/2020-21/07



MECHATOL ENGINEERING SOLUTIONS
CONFER'S TO THAT

Mr. PRITESH SHANMUKH PINGALE

HAS SUCCESSFULLY COMPLETED
ON-JOB TRAINING
ON

DESIGN OF MECHANICAL SYSTEMS

DATED FROM

July 2020 to May 2021

Mr. ANAND BHISE **MECHATOL ENGINEERING SOLUTIONS** DIRECTOR

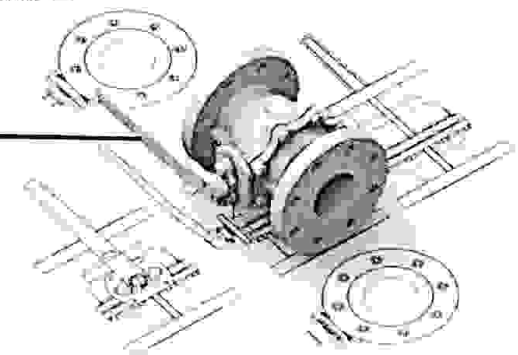



MECHATOL ENGINEERING SOLUTIONS

www.mechatolengg.co.in

CERTIFICATE OF COMPLETION

CERTIFICATE NO: MECHATOL/VIMEET/2020-21/02



MECHATOL ENGINEERING SOLUTIONS
CONFER'S TO THAT

Mr. Rohit Chandrakant Patil

HAS SUCCESSFULLY COMPLETED
ON-JOB TRAINING
ON

DESIGN OF MECHANICAL SYSTEMS

DATED FROM

July 2020 to May 2021

Mr. ANAND BHISE **MECHATOL ENGINEERING SOLUTIONS/DIRECTOR**

TRUE COPY

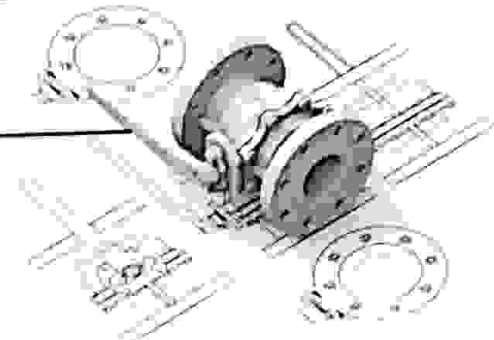

CERTIFICATE OF COMPLETION

CERTIFICATE NO: MECHATROL/VIMEET/2020-21/21



MECHATOL ENGINEERING SOLUTIONS
CONFER'S TO THAT

Mr. Rushabh Vashikar
HAS SUCCESSFULLY COMPLETED
ON-JOB TRAINING
ON

DESIGN OF MECHANICAL SYSTEMS
DATED FROM

July 2020 to May 2021

Mr. ANAND BHISE **MECHATOL ENGINEERING SOLUTIONS/DIRECTOR**

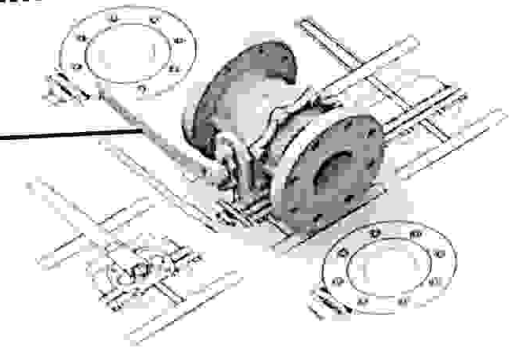

CERTIFICATE OF COMPLETION

CERTIFICATE NO: MECHATROL/VIMEET/2020-21/05



MECHATOL ENGINEERING SOLUTIONS
CONFER'S TO THAT

Mr. Saurabh Sunil Pawar
HAS SUCCESSFULLY COMPLETED
ON-JOB TRAINING
ON

DESIGN OF MECHANICAL SYSTEMS
DATED FROM

July 2020 to May 2021

Mr. ANAND BHISE **MECHATOL ENGINEERING SOLUTIONS DIRECTOR**

TRUE COPY
Vishwanath's (VIMEET)

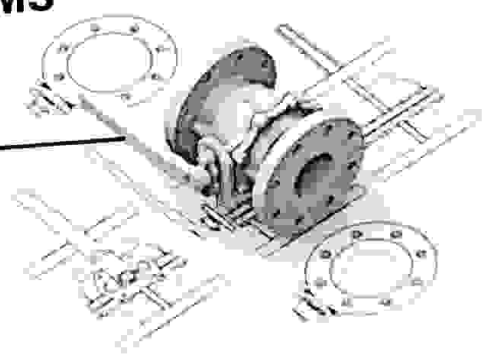

CERTIFICATE OF COMPLETION

CERTIFICATE NO: MECHATROL/VIMEET/2020-21/17



MECHATOL ENGINEERING SOLUTIONS
CONFER'S TO THAT

Mr. Shivam Rajendra Koli
HAS SUCCESSFULLY COMPLETED
ON-JOB TRAINING
ON

DESIGN OF MECHANICAL SYSTEMS
DATED FROM

July 2020 to May 2021

Mr. ANAND BHISE **MECHATOL ENGINEERING SOLUTIONS** DIRECTOR

TRUE COPY
[Signature]
2021

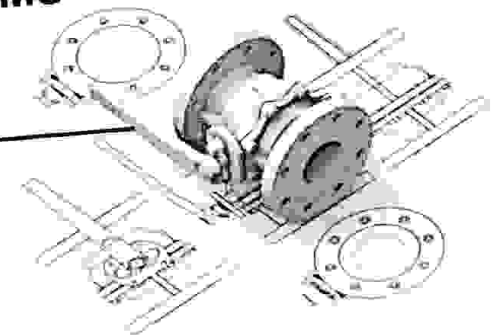

CERTIFICATE OF COMPLETION

CERTIFICATE NO: MECHATROL/VIMEET/2020-21/15



MECHATOL ENGINEERING SOLUTIONS
CONFER'S TO THAT

Mr. SINGH ABHISHEK KUNWAR
HAS SUCCESSFULLY COMPLETED
ON-JOB TRAINING
ON

DESIGN OF MECHANICAL SYSTEMS
DATED FROM

July 2020 to May 2021

Mr. ANAND BHISE **MECHATOL ENGINEERING SOLUTIONS** DIRECTOR

TRUE COPY
Vishwanath Bhise (ASST)

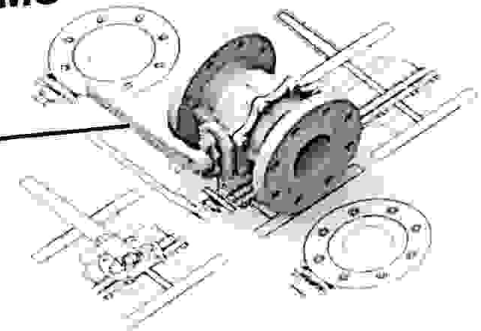

CERTIFICATE OF COMPLETION

CERTIFICATE NO: MECHATROL/VIMEET/2020-21/16



MECHATOL ENGINEERING SOLUTIONS
CONFER'S TO THAT

Mr. Singh Niraj Dharmendra

HAS SUCCESSFULLY COMPLETED
ON-JOB TRAINING
ON

DESIGN OF MECHANICAL SYSTEMS

DATED FROM

July 2020 to May 2021

Mr. ANAND BHISE MECHATOL ENGINEERING SOLUTIONS DIRECTOR

TRUE COPY
Principal
VL In-charge (VIMEET)

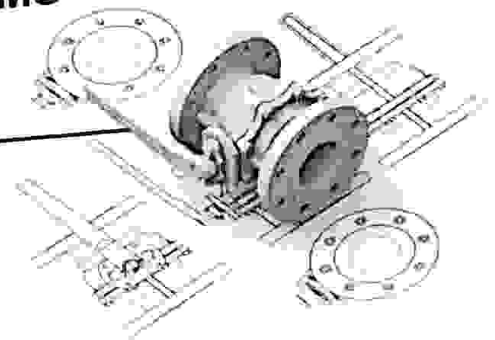

CERTIFICATE OF COMPLETION

CERTIFICATE NO: MECHATROL/VIMEET/2020-21/11



MECHATOL ENGINEERING SOLUTIONS
CONFER'S TO THAT

Mr. Tejas Ghogare
HAS SUCCESSFULLY COMPLETED
ON-JOB TRAINING
ON

DESIGN OF MECHANICAL SYSTEMS
DATED FROM

July 2020 to May 2021

Mr. ANAND BHISE **MECHATOL ENGINEERING SOLUTIONS** DIRECTOR

TRUE COPY

of
Mr. Tejas Ghogare (VIMEET)

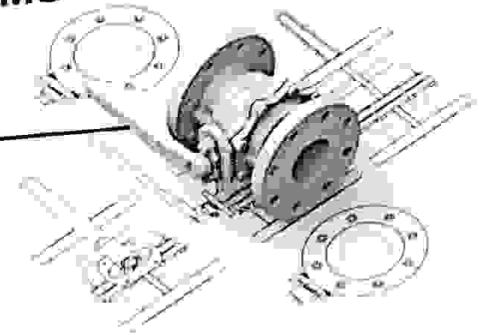



MECHATOL ENGINEERING SOLUTIONS

www.mechatolengg.co.in

CERTIFICATE OF COMPLETION

CERTIFICATE NO: MECHATROL/VIMEET/2020-21/39



MECHATOL ENGINEERING SOLUTIONS
CONFER'S TO THAT

Mr. Thombare Shubham Pradeep

HAS SUCCESSFULLY COMPLETED
ON-JOB TRAINING
ON

DESIGN OF MECHANICAL SYSTEMS

DATED FROM

July 2020 to May 2021

Mr. ANAND BHISE **MECHATOL ENGINEERING SOLUTIONS** DIRECTOR

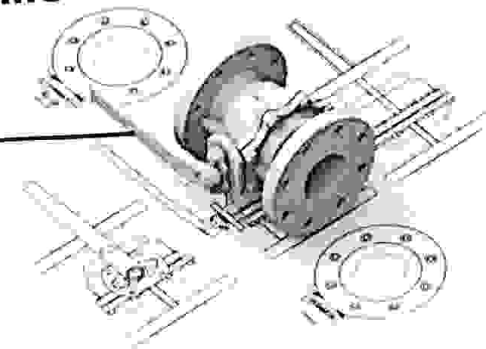

CERTIFICATE OF COMPLETION

CERTIFICATE NO: MECHATROL/VIMEET/2020-21/08



MECHATOL ENGINEERING SOLUTIONS
CONFER'S TO THAT

Mr. Tushar Ravindra Prabhu
HAS SUCCESSFULLY COMPLETED
ON-JOB TRAINING
ON

DESIGN OF MECHANICAL SYSTEMS
DATED FROM

July 2020 to May 2021

Mr. ANAND BHISE **MECHATOL ENGINEERING SOLUTIONS** DIRECTOR

TRUE COPY

Vishnu V. Meete (VIMEET)

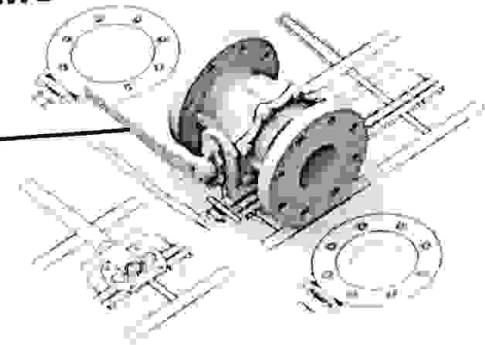

CERTIFICATE OF COMPLETION

CERTIFICATE NO: MECHATROL/VIMEET/2020-21/20



MECHATOL ENGINEERING SOLUTIONS
CONFER'S TO THAT

Mr. Varanshe Shubham Rajendra
HAS SUCCESSFULLY COMPLETED
ON-JOB TRAINING
ON

DESIGN OF MECHANICAL SYSTEMS
DATED FROM

July 2020 to May 2021

Mr. ANAND BHISE **MECHATOL ENGINEERING SOLUTIONS DIRECTOR**

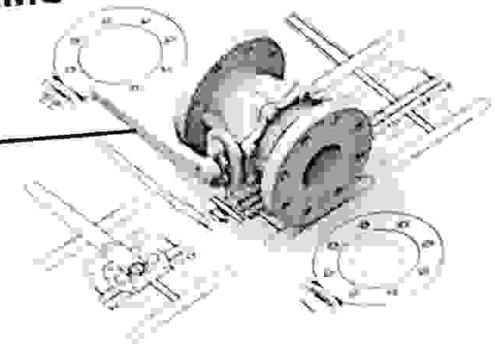



MECHATOL ENGINEERING SOLUTIONS

www.mechatolengg.co.in

CERTIFICATE OF COMPLETION

CERTIFICATE NO: MECHATROL/VIMEET/2020-21/06



MECHATOL ENGINEERING SOLUTIONS
CONFER'S TO THAT

Mr. Ved pawar

HAS SUCCESSFULLY COMPLETED
ON-JOB TRAINING
ON

DESIGN OF MECHANICAL SYSTEMS

DATED FROM

July 2020 to May 2021

Mr. ANAND BHISE **MECHATOL ENGINEERING SOLUTIONS** DIRECTOR

TRUE COPY

Mr. Ved Pawar (VIMEET)

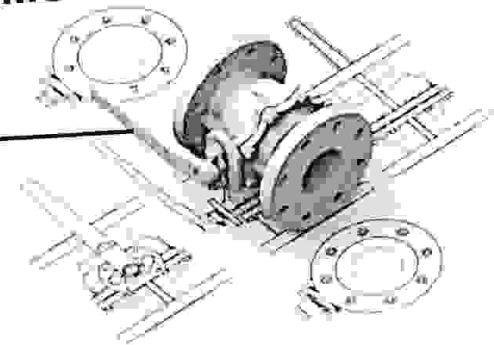

CERTIFICATE OF COMPLETION

CERTIFICATE NO: MECHATROL/VIMEET/2020-21/23



MECHATOL ENGINEERING SOLUTIONS
CONFER'S TO THAT

Mr. Vishwakarma Anuj Lalji

HAS SUCCESSFULLY COMPLETED
ON-JOB TRAINING
ON

DESIGN OF MECHANICAL SYSTEMS

DATED FROM

July 2020 to May 2021

Mr. ANAND BHISE **MECHATOL ENGINEERING SOLUTIONS** DIRECTOR

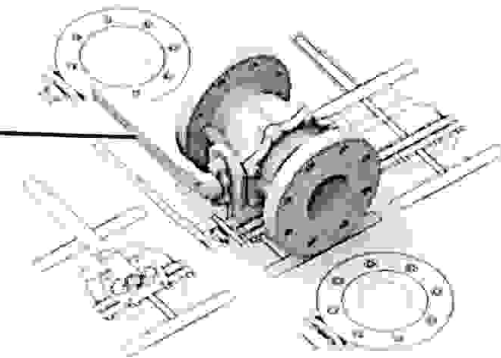

M ECHATOL ENGINEERING SOLUTIONS
www.mechatolengg.co.in

CERTIFICATE OF COMPLETION

CERTIFICATE NO: MECHATROL/VIMEET/2020-21/09



MECHATOL ENGINEERING SOLUTIONS
CONFER'S TO THAT

Mr. Yash Milind Shubhangi Dukhande

HAS SUCCESSFULLY COMPLETED
ON-JOB TRAINING
ON

DESIGN OF MECHANICAL SYSTEMS

DATED FROM

July 2020 to May 2021

Mr. ANAND BHISE **MECHATOL ENGINEERING SOLUTIONS DIRECTOR**

TRUE COPY

(DIRECTOR)

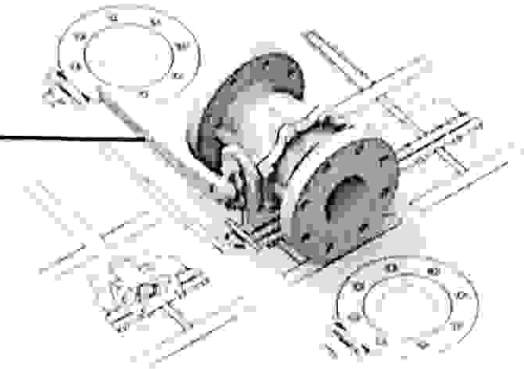

СЕРТИФИКАТ CERTIFICATE

Настоящим удостоверяется, что/
It is hereby certified that

Sachin Laxman Pawar

12 June 2017 - 23 July 2017

прошел(ла) обучение по программе/
attended the course of

Design of Steel and Reinforced Concrete Structures /
Проектирование металлических и железобетонных конструкций



SUMMER
University
2017

№	Модуль образовательной программы/ Educational program module		
	Акаден. часы/ Academic	З.е./ECTS	Балл (%) / Grade (%)
1	Project «Steel and reinforced concrete structures of multiple store buildings»		100
2	Project «Steel and reinforced concrete structures»		100
3	Project «Steel structures of single story industrial buildings»		100
4	Russian language		100
5	IPM		100
6	Practices		100
7	Итого/Totally	3	100

Проректор/Vice-Rector

Директор ДМОП/Director of the DIEP

Reg. номер/Reg. number

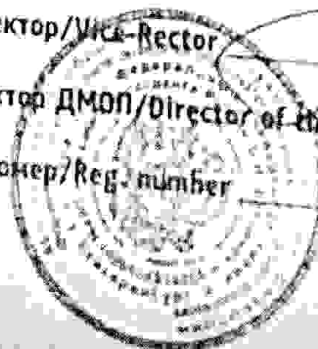

TRUE COPY

Итого/Total (100%)

СЕРТИФИКАТ CERTIFICATE

Настоящим удостоверяется, что/
It is hereby certified that

Soniya Hemnath Kharsambale

12 June 2017 - 23 July 2017

прошел(ла) обучение по программе/
attended the course of

Design of Steel and Reinforced Concrete Structures /
Проектирование металлических и железобетонных
конструкций

№	Модуль образовательной программы / Educational program module		
	Академ. часы / Academic	З.е./ECTS	Балл (%) / Grade (%)
1	Project «Precast reinforced concrete structures of multiple store building»	4	85
2	Russian Language	0,5	100
3	IPM	0,5	100
4	Practices	5	85
5	Итого/Totally	10	85

Проректор/Vice-Rector

Директор ДМОП/Director of the DIEP

Reg. номер/Reg. number

13 11-04/4/159

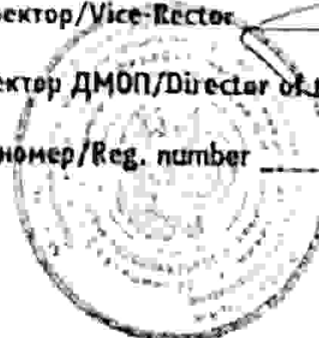

TRUE COPY

[Signature]
Vishwanath's (iNREET)



ITU



VISHWANIKETAN

Certificate of Completion

INTERNATIONAL TECHNOLOGICAL UNIVERSITY
SAN JOSE, CA, USA

This certificate is presented to

Mr. Jafar Yasin Mapara

for successfully completing the UG Fellowship Summer Project and Research Program
under the CTIF-Vishwaniketan Network
from June 18, 2018 to July 27, 2018
at International Technological University

Project Title: Development of Optical Heart Rate Monitor

Gregory M. St. L. O'Brien, Ph.D.
President

TRUE COPY

Pricy Neal
Vishwaniketan's (IME.T)

John L. Lasky, Ph.D.
Project Advisor



ITU

International Technological University
2711 North First Street - San Jose, CA 95134
Phone (888) 488-4968
www.itu.edu

CERTIFICATE OF SCHOLARSHIP

In honor of outstanding performance
in the 2018 UG Fellowship
at International Technological University
We gladly present

Mr. Jafar Yasin Mapara

The Presidential Scholarship of \$2000

When enter a Master's Program at ITU

A scholarship letter will be issued with your acceptance letter



Gregory M. St. L. O'Brien, Ph.D.
President

7/26/2018

Date

Global Development Through Silicon Valley Education

A WASC
ACCREDITED
WASC

TRUE COPY

Principal
Vishwaniketan's (IMEET)

Scanned by CamScanner



ITU



VISHWANIKETAN

Certificate of Completion

INTERNATIONAL TECHNOLOGICAL UNIVERSITY
SAN JOSE, CA, USA

This certificate is presented to

Dr. Janhavi Inamdar

for successfully completing the UG Fellowship Summer Project and Research Program
under the CTIF-Vishwaniketan Network
from June 18, 2018 to July 27, 2018
at International Technological University

Project Title: Development of Optical Heart Rate Monitor

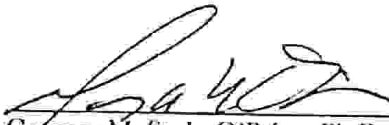

Gregory M. St. L. O'Brien, Ph.D.
President

TRUE COPY

John J. Ladasky II
Vishwaniketan's (IMECT)

John J. Ladasky, Ph.D.
Project Advisor

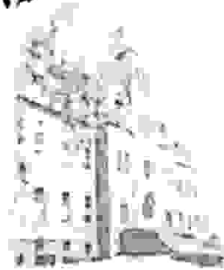
Stevens Institute of Technology



Certificate of Completion

This certificate is awarded to

Akshay Dangare

For successfully completing the

2017 Summer Research Internship on Data Analytics & Visualization

A handwritten signature in black ink, appearing to read "R. Chandramouli".

Rajarathnam Chandramouli
Thomas Hattrick Chair Professor
Schaefer School of Engineering and Science



TRUE COPY

A handwritten signature in black ink, followed by the date "10/10/2017".



Teesside
University

Teesside University
presents this certificate to

Nissim Anil Sadolikar

in thanks for attending the
Teesside University - UG Fellowship
18 June - 30 July 2018
Teesside University, UK

Signed by:

Dr David Bell
Pro Vice-Chancellor, Teesside University

TRUE COPY
Via - [Signature] (M0117)

Scanned with CamScanner



Teesside
University

Teesside University
presents this certificate to

Sarthak Pradip Bapte

in thanks for attending the
Teesside University - UG Fellowship
18 June - 30 July 2018
Teesside University, UK

Signed by:

Dr David Bell

Pro Vice-Chancellor, Teesside University

TRUE COPY
Principal
Vishwanathan's (INNET)

Certificate of Completion

THIS CERTIFICATE IS PROUDLY
PRESENTED TO

PAGAR SHANTANU VIJAY

FOR THE SUCCESSFUL COMPLETION OF
AN INTERNSHIP ENTITLED:
"DESIGN OF PROGRESSIVE SAFETY GEAR FOR ELEVATORS"

INTERNSHIP PERIOD: JUNE - JULY 2018

KALIN CHUCHUDANOV
EMPLOYER



V. Poulkov
VLADIMIR POUSKOV
INTERNSHIP PROGRAM DIRECTOR



Ural Federal
University

named after the first President
of Russia E. A. Yeltsin

ФАКУЛЬТЕТ МЕЖДУНАРОДНЫХ ОБРАЗОВАТЕЛЬНЫХ ПРОГРАММ
им. профессора Протодьякова Павла Е. Н. Екатеринбург
Department of International Educational programs

СЕРТИФИКАТ CERTIFICATE

Настоящим сертифицировано удостоверение, что/

It is hereby certified that

Shantanu Vijay Pagar

Шантану Ваджай Парар

с/from 20 июня/June 2018

по/for 30 июля/July 2018

принял(ла) участие по программе/

attended the course of

Проектно-конструкторские и исследовательские задачи

в машиностроении/ Design of design and research tasks

in mechanical engineering

Educational program module/ Модуль образовательной программы			
№	Academic hours/ Академические часы	ECTS/У.Э	Grade (%) / Балл (%)
1	42	5	100
2	42	5	100
Academic and social aspects of scientific research / Академические и социальные аспекты научных исследований и технологической революции			
3	12	1	100
Final project / Итоговый проект			
4	2	1	100
Total/Итого			100

TRUE COPY

Ver. 1.0 (RMS-T)





UNIVERSITA' DEGLI STUDI DI
ROMA TOR VERGATA
INTERDEPARTMENTAL CENTER— CTIF

INTERNSHIP PERIOD: JUNE - JULY 2018

THIS CERTIFICATE IS PROUDLY
PRESENTED TO
Gurav Jatin Mahesh

FOR THE SUCCESSFUL COMPLETION OF AN INTERNSHIP ENTITLED
**EXPERIMENTAL EVALUATION OF A LINK BASED ON LORA
STANDARD**

Supervisor
Prof. Ernestina Cianca
Ernestina Cianca

TRUE COPY

[Signature]
CTIF (IMEET)

Vice-Director of CTIF
Prof. Ernestina Cianca
Ernestina Cianca



**UA
LITTLE
ROCK**

JULY 27, 2018

Sayon Karmakar

secured a UG Fellowship 2018, offered by Vishwaniketan-CGC Network, and has pursued the research project titled

DRIVER DROWSINESS DETECTION SYSTEM

during the period June 19, 2018 to July 27, 2018, a 6-week Research Internship program, conducted at UA Little Rock, USA, under the guidance of Professors Dr. Seshadri Mohan and Dr. Mariofanna Milanova, and has successfully completed the project.



Dr. Seshadri Mohan
Professor, Systems Eng.
Director, UA Little Rock
Vishwaniketan Summer
Internship Program



Dr. Mariofanna Milanova
Professor, Computer Science,
UA Little Rock, USA



Dr. Lawrence Whitman
Dean, EIT, UA Little Rock, USA

Principal
Vishwaniketan's (Institute)



**CERTIFICATE
OF
COMPLETION**



СЕРТИФИКАТ CERTIFICATE

Настоящим удостоверяется, что/
It is hereby certified that

Джаткар Айяз Хуссейн
Jatkar Ayyaz Hussain

с/from 18 Июня / June 2018

по/to 26 Июля / July 2018

прошел(на) обучение по программе/
attended the course of

Машиностроение / Mechanical engineering

№	Модуль образовательной программы/ Educational program module		
	Академ. часы/ Academic	З.е./ECTS	Балл (%) / Grade (%)
1	Технология производства / Production Engineering		
	72	2	95
2	Теория решения изобретательских задач / Theory of Inventive Problem Solving		
	72	2	90
3	Разработка манипулятора загрузки кольцевой печи труб- вобратного агрегата / Design of Handling Manipulator for Ring Furnace of Pipe-Forming Unit		
	144	4	88
4	Итого / Totally		
	288	8	91

Проректор / Vice-Rector

Директор ДМОП / Director of the DIEP

Рег. номер / Reg. number 33 18-04/4135

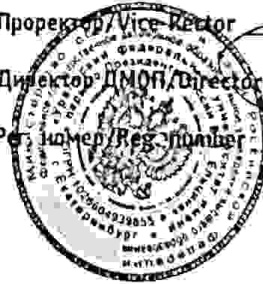

TRUE COPY

[Signature]
Vishwanath Reddy (DIEP)

application@urfu.ru



AIT
CENTER
OF EXCELLENCE
FOR RESEARCH
AND EDUCATION



CERTIFICATE OF PROJECT COMPLETION

July 25th, 2019
AIT, Athens, Greece

It is certified that

KOMAL GURAV

has successfully completed the
**UG Fellowship Summer Project and Research Program under the CTiF- Vishwaniketan-
GISFI Network.**

Project Title: Blockchain Based E-voting System

Internship Period: June 19th, 2019 to July 25th, 2019

Sofoklis Efremidis
Program Director
AIT

TRUE COPY
Principal
Vishwaniketan's (IMEET)

Academic Advisor
AIT



AIT
CENTER
OF EXCELLENCE
FOR RESEARCH
AND EDUCATION

★ **CERTIFICATE** ★

ATHENS INFORMATION TECHNOLOGY, GREECE

Certifies that

PRANJAL PRADIP BHOSEKAR

attended and successfully completed the LG Fellowship Summer
Project and Research Program under the CTIFW Anwarifstar-GISEF
Network.

Project Title: ULA Beamforming

Internship Period: 19th June 2017 to 27th July 2017

Papadakis Constantinos
Scientific Director

TRUE COPY
Vishwajit

Prevedourou Eudoxia
Managing Director

Certificate of Completion

THIS CERTIFICATE IS PROUDLY
PRESENTED TO

Simran Krishnanath Wani

FOR THE SUCCESSFUL COMPLETION OF
AN INTERNSHIP ENTITLED:
"Smart homes IoT based"

INTERNSHIP PERIOD: JUNE - JULY 2017

TRUE COPY

Printed
Vishwanath
Dimitre Dichev
SUPERVISOR



V. Poulkov
VLADIMIR POULKOV
Internship Program Director



UNIVERSITA' DEGLI STUDI DI
ROMA TOR VERGATA
INTERDEPARTMENTAL CENTER— CTIF

INTERNSHIP PERIOD: JUNE – JULY 2017

THIS CERTIFICATE IS PROUDLY
PRESENTED TO

OMKAR SOMESHWAR KOKANE

FOR THE SUCCESSFUL COMPLETION OF AN INTERNSHIP ENTITLED
**BIOCHAR PRODUCTION IN INDIA BY RESIDUAL BIOMASSES: SMALL
SCALE POTENTIAL**

Supervisor
Dr. *Alessandro Manni*

TRUE COPY

Prof. Alessandra Manni (MANNI)

Vice-Director of CTIF
Prof. *Ernestina Cianca*



**UA
LITTLE
ROCK**

JULY 27, 2018

Sayon Karmakar

secured a UG Fellowship 2018, offered by Vishwaniketan-CGC
Network, and has pursued the research project titled

DRIVER DROWSINESS DETECTION SYSTEM

during the period June 19, 2018 to July 27, 2018, a 6-week Research Internship
program, conducted at UA Little Rock, USA, under the guidance of Professors
Dr. Seshadri Mohan and Dr. Mariofanna Milanova, and has successfully
completed the project.



Dr. Seshadri Mohan
Professor, Systems Eng.
Director, UA Little Rock
Vishwaniketan Summer
Internship Program



Dr. Mariofanna Milanova
Professor, Computer Science,
UA Little Rock, USA

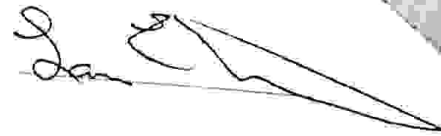

Dr. Lawrence Whitman
Dean, EIT, UA Little Rock, USA



Principal
Vishwaniketan's (iVSEET)



**CERTIFICATE
OF
COMPLETION**



TRUE COPY



Ministry of Education and Science of Ukraine
 National Technical University of Ukraine "Igor Sikorsky Kyiv Polytechnic Institute"

Certificate

OF ADVANCED TRAINING AND SPECIALIZATION

SERIES UGF NUMBER/201726

SHREYASH SHRIKANT NAKHAWA

INTERNSHIP PERIOD: 17 JUNE 2017 TO 29 JULY 2017

Advanced his/her qualification at the Institute of Mechanical Engineering according to UG FELLOWSHIP SUMMER PROJECT & RESEARCH PROGRAM CGC VISHWANIKETAN NETWORK held by this department. During the summer internship candidate has studied and worked on following projects:

Description of Project	Number of ECTS credits	Grades registered at the Sending Institution
Stress Analysis of Plates Joint under Static Loading: Part Number 62350021M004	7	95 Excellent A

Total Scope of Internship Program: 210 (teaching hours) and ECTS Credits of 7

Thesis on Summer Internship program has been submitted to us and he/she has successfully completed internship with "A" Grade.

First Vice-Rector



[Signature]
/Y. Yakymenko/

Director of Mechanical Engineering Institute

[Signature]
/M. Bobyr/



TRUE COPY

31/08/2017

СЕРТИФИКАТ CERTIFICATE

Настоящим удостоверяется, что/
It is hereby certified that

Manish Dattaram Rane
Маниш Даттарам Рейн

с/from 17 Июня / June 2019
по/to 26. Июля / July 2019

прошел(ла) обучение по программе/
attended the internship in the field of:

Энергетика / Power engineering

№	Модуль образовательной программы/ Educational program module		
	Академ. часы/ Academic	З.е./ECTS	Балл (%) / Grade (%)
1	Общая инженерия / Common engineering course		
	20	2	75
2	Проект / Project work Machine Learning and AI in the Renewable Energy Sector		
	12	6	85
3	Русский язык / Russian language		
	4		100
4	Extra project (optional)		
5	Extra project (optional)		
6	Extra project (optional)		
	Итого/Totally		
	96	8	200

Проректор / Vice-Rector

Директор ДМОП / Director of the DIEP

Рег. номер / Reg. number 33.18-04/4/81

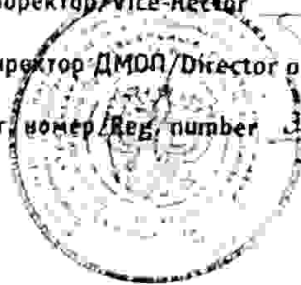

TRUE COPY

Vishwanath K. S. (RECT)

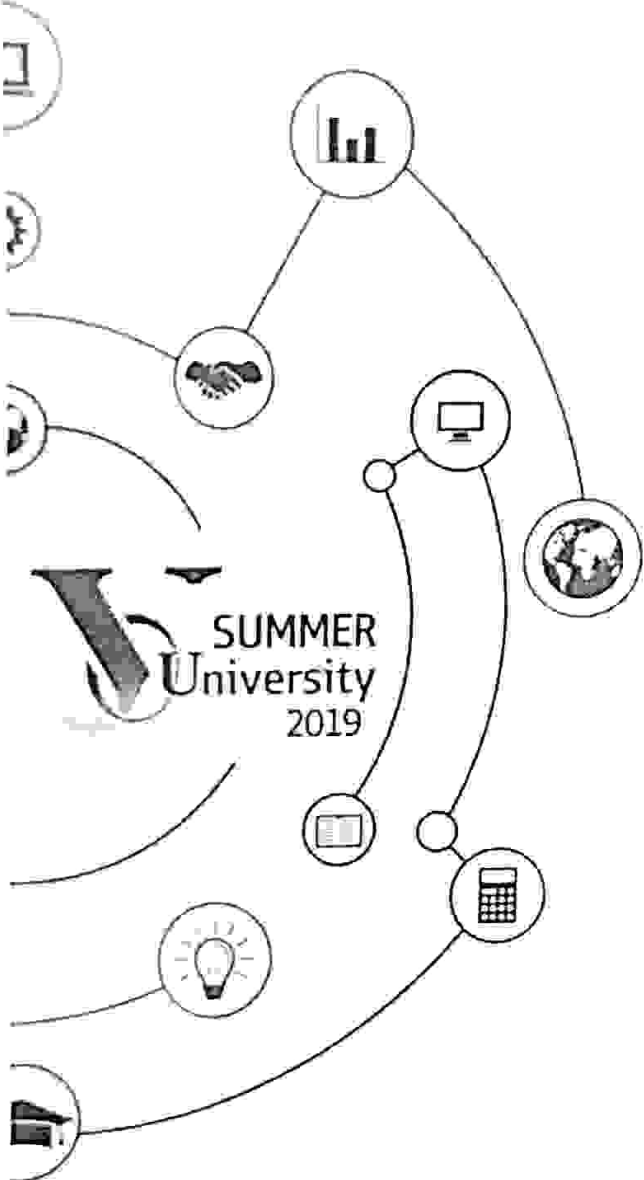

application@urfu.ru

BEST TEAM

Ideathone-2019

Nachiket Yuvaraj Badgujar

is awarded for the best project dedicated to

Collection of waste
particles from rollers
and nano technology

and outstanding results in team work.

Knyazev Sergey
UrFU Vice rector

ChelPipe group

High-Tech Technopark "Universitetsky"

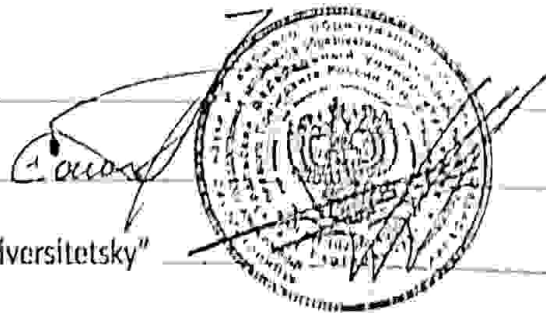

TRUE COPY

Vishwanikant's (0.04 ET)

ФГАОУ ВО «Уральский федеральный университет имени первого Президента России Б.Н. Ельцина»

Department of International Educational Programs

 Ural Federal University

СЕРТИФИКАТ CERTIFICATE

Настоящим удостоверяется, что/
It is hereby certified that

Nachiket Yuvaraj Vadgujar
Начикет Юварадж Бадгуджар

с/from 17 Июня / June 2019

по/to 26 Июля / July 2019

прошел(ла) обучение по программе/
attended the internship in the field of:

Машиностроение / Mechanical engineering

№	Модуль образовательной программы/ Educational program module		
	Академ. часы/ Academic	З.е./ECTS	Балл (%) / Grade (%)
1	Общая инженерия/Common engineering course		
	20	2	75
2	Проект: / Project work: Design of automatic system of utilization for organic waste		
	72	6	98
3	Русский язык / Russian language		
	4		100
4	Extra project (optional):		
5	Extra project (optional):		
6	Extra project (optional):		
Итого/Totally			
	96	8	243

Проректор/Vice-Rector

Директор ДМОП/Director of the DIEP

Рег. номер/Reg. number

3.18-04/4/70



TRUE COPY

application@urfu.ru



CERTIFICATE OF COMPLETION

Teesside University presents this certificate to

Kshitij Jaikrishna Patle

For completing a 6 week Summer Research Internship Programme
at Teesside University, Middlesbrough, Teesside, UK
during the period 19th June 2019 – 28th July 2019

Project Title:

"Design and optimisation of Formula race car by studying Aerodynamics
using CFD analysis" under the guidance of Dr. Faik Hamad

Dr David Bell
Pro Vice-Chancellor, International
Teesside University

Mr George Hunt
Director International Development
Teesside University

TRUE COPY

Principal
Vishwaniketan (ISET)

Dr Kevin Thomas
Associate Dean International
School of Science, Engineering & Design
Teesside University



Ministry of Education and Science of Ukraine

National Technical University of Ukraine "Kyiv Polytechnic Institute of Igor Sikorsky"

Certificate

OF ADVANCED TRAINING AND SPECIALIZATION

SERIES UGF NUMBER/201701

ROUSHAN VIJAY PANDEY

INTERNSHIP PERIOD: 17 JUNE 2017 TO 29 JULY 2017

Advanced his/her qualification at the Faculty of electrical Power Engineering & Automatics according to **UG FELLOWSHIP SUMMER PROJECT & RESEARCH PROGRAM CTIF VISHWANIKETAN NETWORK** held by this department. During the summer internship candidate has studied and worked on following mentioned topics:

Sr. No.	Description of Topic	Grade
1	Calculation of the operating mode of the photovoltaic power plant in parallel operation on the distribution network	A
2	Fundamentals of automation systems design with digital, analog integrated circuits and Programmable Logic Controllers	A
2.1	Implementation of analog and digital circuits on control boards	A
2.2	Fundamentals of automation systems design with digital integrated circuits	A
2.3	Automation system design using Programmable Logic Controllers	A

Total Scope of Internship Program: 136 (teaching hours)

Thesis on Summer Internship program is been submitted to us and he/she has successfully completed internship with "A" Grade.

Rector (Vice-rector)

Director of TMC "Institute for Continuing Education and Training"

TRUE COPY

Printed
Vishwaniketans (IMEET)



Ministry of Education and Science of Ukraine
National Technical University of Ukraine "Kyiv Polytechnic Institute
of Igor Sikorsky"

Certificate

OF ADVANCED TRAINING AND SPECIALIZATION

SERIES UGF NUMBER/201701

PANKAJ PANDIT AHIRE

INTERNSHIP PERIOD: 17 JUNE 2017 TO 29 JULY 2017

Advanced his/her qualification at the Faculty of electrical Power Engineering & Automatics according to UG FELLOWSHIP SUMMER PROJECT & RESEARCH PROGRAM CTIF VISHWANIKETAN NETWORK held by this department. During the summer internship candidate has studied and worked on following mentioned topics:

Sr. No.	Description of Topic	Grade
1	Theoretical and practical issues in development of variable frequency drives	A
1.1	Basics of Induction motor Control	A
1.2	Frequency converter design	A
2	Programmable Logic Controllers	A
3	Practical methods of Short Circuit current calculations	A
4	Protection of Low voltage radial Distribution system and High Voltage line and transformer relay protection	A

Total Scope of Internship Program: 136 (teaching hours)

Thesis on Summer Internship program is been submitted to us and he/she has successfully completed internship with 'A' Grade.

Rector (Vice-rector)

Director of TMC "Institute for Continuing Education and Training"

TRUE COPY

GRATITUDE

Summer University 2019

Pallavi Sakhahari Dhamak

Awarded for the invaluable contribution and assistance
in organizing and conducting international educational program
"Summer University 2019".

TRUE COPY

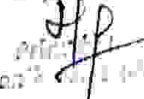
Vishwanath (Name)

Victor
Koksharov
Rector





**Уральский
Федеральный
университет**

имени первого Президента
России Б.Н.Ельцина

Министерство науки и высшего образования Российской Федерации
Федеральное государственное автономное образовательное учреждение
высшего образования «Уральский федеральный университет
имени первого Президента России Б.Н. Ельцина» (УрФУ)

ул. Мира, 19, Екатеринбург, 620002,
факс: +7 (343) 375-97-78; тел.: +7 (343) 374-38-84
контакт-центр: +7 (343) 375-44-44, 8-800-100-50-44 (звонок бесплатный)
e-mail: rector@urfu.ru, www.urfu.ru
ОКПО 02069208, ОГРН 1026604939855, ИНН/КПП 6660003190/667001001

24.07.2019 № 33 18-06/57
на № _____ от _____

Reference letter

To whom it may concern,

Hereby we would like to confirm that Siddhant Sanjay Mhatre was one of the brightest students of Summer Training Program 2019 at Ural Federal University, Yekaterinburg, Russia. During his training program, he developed the projects named Steel structures of industrial or public building, HRM. We found him to be an active and assiduous student, who excelled at most activities in which he was taking part.

He is well versed, enthusiastic and promising student. His respectful and polite nature made him different from all others. Within the program, he actively participated in different extra-activities, such as:

- ✓ Malahit school (July 1 – 4, AI, ML, data Analysis work-shops from international experts);
- ✓ Ideathone 2019 (July 8 – 10, an international student engineering competition for 3 days, with tasks from real companies of Ural Region);
- ✓ Practices in inter-regional Center of Skills (Industrial robots laboratory, material science laboratory, industrial process automation laboratory).

He always maintained an amicable attitude, which allowed him to complete successfully his project with teammates. We identify him as a self-confident person, who is highly efficient and dedicated towards his work. He kept good relationships with professors and other staff during not only training program but also when he returned to India. He is a reliable and disciplined student, who has the capacity of adapting himself to new and challenging environments.

You may contact Director of the Department of International education programs Mrs. Iana Vysotskaia (Aymasheva) at 8 (343) 375-93-59 if you have any questions or require additional information.

Vice-rector for academic affairs



[Handwritten signature]

Sergey T.Knyazev

TRUE COPY

[Handwritten signature]
Vishwanath (MECT)

СЕРТИФИКАТ CERTIFICATE

Настоящим удостоверяется, что/
It is hereby certified that

Siddhant Sanjay Mhatre
Сиддхант Санджай Мхатре

с/from 17 Июня / June 2019

по/to 26 Июля / July 2019

прошел(ла) обучение по программе/
attended the internship in the field of:

Строительство / Civil engineering

№	Модуль образовательной программы/ Educational program module		
	Академ. часы/ Academic	З.е./ECTS	Балл (%) / Grade (%)
1	Общая инженерия/Common engineering course		
	20	2	100
2	Проект: / Project work: Steel structures of industrial or public building		
	72	6	90
3	Русский язык / Russian language		
	4		100
4	Extra project (optional): HRM		
	-	-	-
5	Extra project (optional):		
6	Extra project (optional):		
Итого/Totally			
	96	8	290

Проректор/Vice Rector

Директор ДМОП/Director of the DIEP

Рег. номер/Reg. number

18-04/4/124



TRUE COPY

Vishwanath (12/11/2017)

application@urfu.ru

RECOMMENDATION LETTER

February 20, 2019

To: TO WHOM IT MAY CONCERN

From: Dr. Mariofanna Milanova
Professor
Computer Science Department
University of Arkansas at Little Rock
2801 S. University Ave., Little Rock, Arkansas 72204-1099
Ph: (501) 569-8135; Fax: (501) 569-8144
E-mail: mgmilanova@ualr.edu

Applicant: Ms. Shivani Shimpi

Dear Colleagues,

It gives me great pleasure to write a letter of recommendation for Ms. Shivani Shimpi.

I have known Ms. Shimpi for a little over three months now. I had the chance to learn about Shivani more closely when she worked with me as a Teaching Assistant in a Machine Learning workshop this year. She has enthusiasm to learn beyond the scope of the syllabus. I personally appreciate her pragmatic approach in learning and analyzing newer mathematical techniques, which contributed to her intellectual capital. Her innovative thinking and dedication have earned her academic success. Shivani's practicality and adaptability in problem solving sessions have greatly contributed in attaining academic excellence. I think she has the capability to carry any teaching assignment effectively. Her presentation skills are excellent and ideally suited for both the academic and corporate settings. She has command of both the theoretical aspects of computing and the practical applications. Also, her research skills are very strong.

Shivani often made critical points in the class discussions and was among the top students in the class. She is a hardworking and motivated student. I have been impressed by her good ideas, but more so by her ability to start projects and propose research topics herself. Being self-motivated, Shivani works well alone, however, she also does well in team projects. As a student, she is a good listener, highly attentive, ambitious, and enthusiastic.

I recall other colleagues being also impressed with Shivani's work, so much so, that they invited her to assist with and participate in different projects. As a result of her critical analysis, she secured a top All India Rank of 1079 in the Joint Entrance Examination for admissions in Indian Institute of Technology among 0.15 million contesting candidates. Her excellence in mathematics led to her selection among the

University of Arkansas at Little Rock • 2801 South University Avenue • Little Rock, AR 72204
Phone: (501)-569-8130 • Fax: (501)-569-8144 • e-mail: csdept@ualr.edu

TRUE COPY

Vishwanath's (VWEET)

top 15 candidates from the country to represent India at International Mathematics Olympiad (IMO), Chiang Mai, Thailand and among the top 5 candidates from the country to represent India at International Astronomy and Astrophysics Olympiad (IAAO), Bhubaneswar, India.
Shruti successfully finished seven different programs for 2 years and got the certificates from several companies and Universities.

In closing, Shruti is a hardworking, loyal and adaptable teacher and researcher. She is very easy to work with and quite motivational. Her ambitions, combined with determination and emotional maturity have allowed her to lead and motivate both our team and the student body. Shruti is capable to teach new and challenging courses, to develop novel methods, algorithms, and research tools, to publish quality research papers. As a personal comment, I have observed Shruti to be very honest, genuine and devoted. She seems to have her life priorities in order.

On the basis of all this, I am confident that Ms. Shruti Shrivastava would be a strong asset to your University. I recommend her to you highly.

Sincerely,



Dr. Manojendra Mishra

TRUE COPY

University of Arkansas at Little Rock • 2801 South University Avenue • Little Rock, AR 72204
Phone: (501)-569-8130 • Fax: (501)-569-8144 • e-mail: csdept@ualr.edu



AIT
CENTER
OF EXCELLENCE
FOR RESEARCH
AND EDUCATION



CERTIFICATE OF PROJECT COMPLETION

July 25th, 2019
AIT, Athens, Greece

It is certified that

Prof. Sneha Patil

has successfully completed the
UG Fellowship Summer Project and Research Program under the CTiF- Vishwaniketan-
GISFI Network.

Project Title: - **Antenna Designing**

Internship Period: June 19th, 2019 to July 25th, 2019

Sofoklis Efremidis
Program Director
AIT

Academic Advisor
AIT

TRUE COPY

VISHWANIKETAN (ATHENS)

RECOMMENDATION LETTER

February 20, 2019

To: TO WHOM IT MAY CONCERN

From: Dr. Mariofanna Milanova
Professor
Computer Science Department
University of Arkansas at Little Rock
2801 S. University Ave., Little Rock, Arkansas 72204-1099
Ph: (501) 569-8135; Fax: (501) 569-8144
E-mail: mgmilanova@ualr.edu

Applicant: Ms. Shivani Shimpi

Dear Colleagues,

It gives me great pleasure to write a letter of recommendation for Ms. Shivani Shimpi.

I have known Ms. Shimpi for a little over three months now. I had the chance to learn about Shivani more closely when she worked with me as a Teaching Assistant in a Machine Learning workshop this year. She has enthusiasm to learn beyond the scope of the syllabus. I personally appreciate her pragmatic approach in learning and analyzing newer mathematical techniques, which contributed to her intellectual capital. Her innovative thinking and dedication have earned her academic success. Shivani's practicality and adaptability in problem solving sessions have greatly contributed in attaining academic excellence. I think she has the capability to carry any teaching assignment effectively. Her presentation skills are excellent and ideally suited for both the academic and corporate settings. She has command of both the theoretical aspects of computing and the practical applications. Also, her research skills are very strong.

Shivani often made critical points in the class discussions and was among the top students in the class. She is a hardworking and motivated student. I have been impressed by her good ideas, but more so by her ability to start projects and propose research topics herself. Being self-motivated, Shivani works well alone, however, she also does well in team projects. As a student, she is a good listener, highly attentive, ambitious, and enthusiastic.

I recall other colleagues being also impressed with Shivani's work, so much so, that they invited her to assist with and participate in different projects. As a result of her critical analysis, she secured a top All India Rank of 1079 in the Joint Entrance Examination for admissions in Indian Institute of Technology among 0.15 million contesting candidates. Her excellence in mathematics led to her selection among the

University of Arkansas at Little Rock • 2801 South University Avenue • Little Rock, AR 72204
Phone: (501)-569-8130 • Fax: (501)-569-8144 • e-mail: csdept@ualr.edu

TRUE COPY

Vishwanath (MSEE)

top 15 candidates from the country to represent India at International Mathematics Olympiad (IMO), Chiang Mai, Thailand and among the top 5 candidates from the country to represent India at International Astronomy and Astrophysics Olympiad (IOAA), Bhubaneshwar, India.
Shivani successfully finished seven different programs for 2 years and got the certificates from several companies and Universities.

In closing, Shivani is a hardworking, loyal and adaptable teacher and researcher. She is very easy to work with and quite inspirational. Her ambition, combined with determinism and emotional maturity have allowed her to lead and motivate both our team and the student body. Shivani is capable to teach new and challenging courses, to develop novel methods, algorithms, and research tools, to publish quality research papers. As a personal comment, I have observed Shivani to be very honest, genuine and devoted. She seems to have her life priorities in order.

On the basis of all this, I am confident that Ms. Shivani Shimpi would be a strong asset to your University. I recommend her to you highly.

Sincerely,



Dr. Mariofanna Milanova

TRUE COPY



University of Arkansas at Little Rock • 2801 South University Avenue • Little Rock, AR 72204
Phone: (501)-569-8130 • Fax: (501)-569-8144 • e-mail: csdept@ualr.edu



VISHWANIKETAN



Mae Fah Luang University Thailand



Certificate of Appreciation of the Program

This is to certify that

MS SWAPNA MANURKAR

of Vishwaniketan India

Vishwaniketan India was here as a supervisor under CGC Vishwaniketan Network's UG Fellowship program 2019 for a team of 4 students from 22 June to 26 July 2019

Her dedicated efforts are worth commendable and have contributed towards successful completion of UG Fellowship Program 2019 in MFU Thailand

We wish her every success in her future endeavors

Teeravisit Laohapensaeng, Ph D
Dean, School of Information Technology
Mae Fah Luang University Thailand

TRUE COPY

Principal
Vishwaniketan (INIGET)

Assoc Prof Nantana Gajasen, Ph D
Vice President
Mae Fah Luang University Thailand

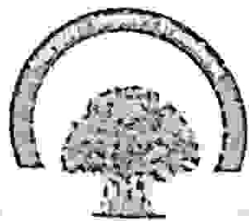

VISHWANIKETAN



Mae Fah Luang University



Certificate of Completion of the Programme
This is to certify that

MR. MOKAL VARUN VIKAS

Student of Vishwaniketan's Institute of Management
Entrepreneurship & Engineering Technology

has successfully completed a research exchange under
the UG Fellowship Programme at Mae Fah Luang University, Thailand

Teeravisit Laohapensaeng, Ph.D.
Dean, School of Information Technology
Mae Fah Luang University

Assoc. Prof. Nantana Gajaseeni, Ph.D.
Vice President
Mae Fah Luang University

Poznan University of Technology, Poland



CERTIFICATE OF APPRECIATION
of Advanced Training and Specialization

this is to certify that Mr. Rupesh Ajit Devale, Assistant professor, Vishwaniketan India, was here a supervisor under CTC Vishwaniketan Network's UG Fellowship programme 2019 for a team of 14 students from 18th of June 18 till 28th of July, 2019. His dedicated efforts are worth commendable and have contributed towards successful completion of UG Fellowship programme 2019 in Poznan University of Technology, Poland .

We wish him every success in his future endeavors.

Prof. Teofil JESIONOWSKI, Ph.D., D.Sc.

Vice-Rector for Lifelong Learning and
International Education

Mgr. Magdalena ZAWIRSKA-WOLNIEWICZ

Head of LLL&International
Education Office

TRUE COPY

J
Principal
Vishwaniketan's (IMDET)

Scanned with CamScanner

Poznan University of Technology, Poland



CERTIFICATE OF APPRECIATION

Serial UGF Number: *LD1713*

of Advanced Training and Specialization

SUVIDHA SAROJKUMAR MIATRE

Internship period: 18 June - 28 July 2019

Advanced his/her qualification at the Faculty of Electrical Engineering according to the project UG Fellowship Summer Project & Research Program CGC Nishwadekshan Network held by this department.

During the summer internship candidate has studied and worked on following mentioned topics:

No	Description of project	Number of ECTS credits	Grades registered at the sending Institution
1	Microprocessor control of the current flow between the hybrid energy storage and the receiver	7	

Successfully completed internship with Grade

Total Scope of Internship program: 198 (teaching hours) and ECTS Credits of 7.

Prof. Teofil JESIONOWSKI, Ph.D., D.Sc.

Vice-Rector for Lifelong Learning and International Education

[Handwritten signature]
Damian Burzyński, M.Sc.

Supervisor



CERTIFICATE OF COMPLETION

Teesside University presents this certificate to

Deovrut Dashrath Jadhav

For completing a 6 week Summer Research Internship Programme
at Teesside University Middlesbrough, Teesside, UK
during the period 10th June 2019 - 28th July 2019

Project Title:

"Nutrition Management in Hydroponics, Aquaponics & Aeroponics"
under the guidance of Mr. Nigel Atkinson

DB
Deputy Director
Teesside University
Middlesbrough
TS1 1BA

Li
Lecturer
Teesside University
Middlesbrough
TS1 1BA
TRUE COPY

Deovrut Jadhav
Deputy Director
Teesside University
Middlesbrough
TS1 1BA

De
Deputy Director
Teesside University
Middlesbrough
TS1 1BA



CERTIFICATE OF COMPLETION

Teesside University presents this certificate to

Simran Krishnanath Wani

For completing a 6 week Summer Research Internship Programme
at Teesside University, Middlesbrough, Teesside, UK
during the period 19th June 2019 – 28th July 2019

Project Title:

"Idrivezy Business Model"
under the guidance of Mr. Steve Dougan

Dr David Bell
Pro Vice-Chancellor, International
International
Teesside University

Mr George Hunt
Director, International Development
International
Teesside University

Dr Kevin Thomas
Associate Dean, International
School of Science, Engineering & Design
Teesside University

СЕРТИФИКАТ CERTIFICATE

Настоящим удостоверяется, что/
It is hereby certified that

Salman Taslim Mujawar
Салман Таслим Муджавар

с/from 17 Июня / June 2019
по/to 26 Июля / July 2019

прошел(ла) обучение по программе/
attended the internship in the field of:

Строительство / Civil engineering

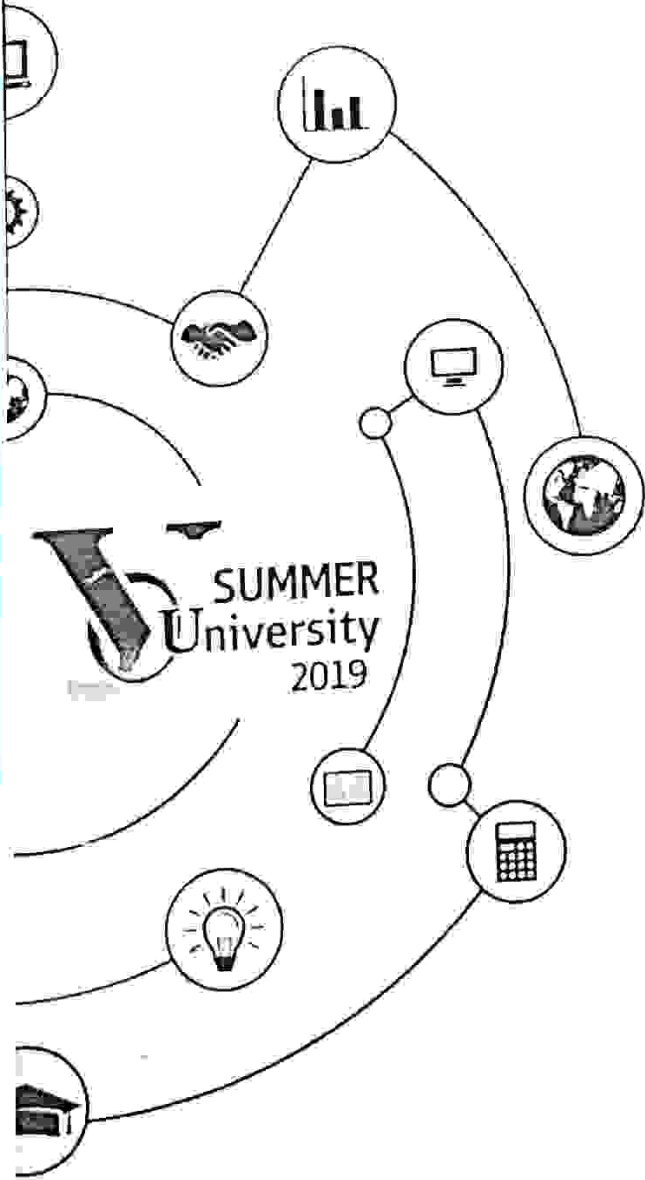

№	Модуль образовательной программы/ Educational program module		
	Академ. часы/ Academic	З.е./ECTS	Балл (%) / Grade (%)
1	Общая инженерия / Common engineering course		
	20	2	75
2	Проект: / Project work: Reinforced concrete structures of public building		
	72	6	90
3	Русский язык / Russian language		
	4		100
4	Extra project (optional): Effects of financial and non-financial staff productivity		
			90
5	Extra project (optional):		
6	Extra project (optional):		
	Итого/Totally		
	96	8	355

Проректор/Vice-Rector

Директор ДМОП/Director of the DIEP

Рег. номер/Reg. number

38 18-04/4/120

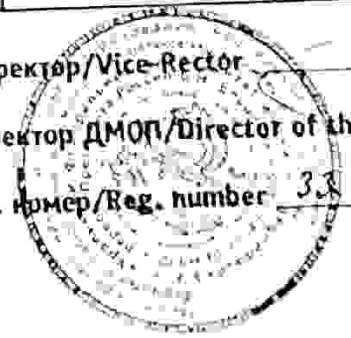

TRUE COPY

VISITORS (DIRECT)

application@urfu.ru

24.07.2019 № 3318 DE/ES
на № _____ от _____

Reference letter

To whom it may concern,

Hereby we would like to confirm that **Salman Taslim Mujawar** was one of the brightest students of Summer Training Program 2019 at Ural Federal University, Yekaterinburg, Russia. During his training program, he developed the projects named Reinforced concrete structures of public building. We found him to be an active and assiduous student, who excelled at most activities in which he was taking part.

He is well versed, enthusiastic and promising student. His respectful and polite nature made him different from all others. Within the program, he actively participated in different extra-activities, such as:

- ✓ Malahit school (July 1 – 4, AI, ML, data Analysis work-shops from international experts).
- ✓ Ideathone 2019 (July 8 – 10, an international student engineering competition for 3 days, with tasks from real companies of Ural Region);
- ✓ Practices in Inter-regional Center of Skills (industrial robots laboratory, material science laboratory, industrial process automation laboratory).

He always maintained an amicable attitude, which allowed him to complete successfully his project with teammates. We identify him as a self-confident person, who is highly efficient and dedicated towards his work. He kept good relationships with professors and other staff during not only training program but also when he returned to India. He is a reliable and disciplined student, who has the capacity of adapting himself to new and challenging environments

You may contact Director of the Department of International education programs Mrs. Iana Vysotskaia (Aymasheva) at 8 (343) 375-93-59 if you have any questions or require additional information.

Vice-rector for academic affairs

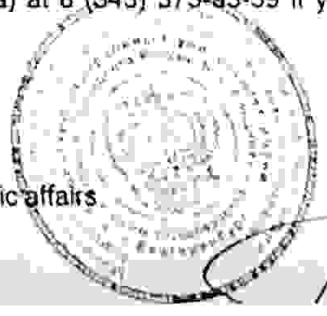

[Handwritten signature]

[Handwritten signature]

Sergey T. Knyazev



Уральский федеральный университет
 Урал Федерал Университи
 Department of International Educational Programs

СЕРТИФИКАТ CERTIFICATE

Настоящим удостоверяется, что/
 It is hereby certified that

Milan Lalit Dandekar
Милан Лалит Дандекар

с/from 17 Июня / June 2019
 по/to 26 Июля / July 2019

прошел(ла) обучение по программе/
 attended the internship in the field of

Строительство / Civil engineering

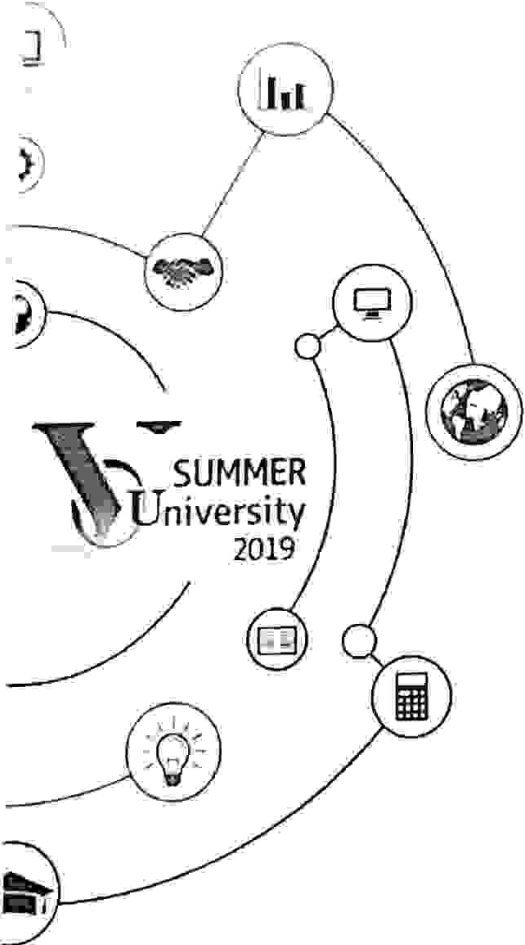

№	Модуль образовательной программы/ Educational program module		
	Академ. часы/ Academic	З.е./ECTS	Балл (%) / Grade (%)
1	Общая инженерия/Common engineering course		
	20	2	100
2	Проект: / Project work. Reinforced concrete structures of public building		
	72	6	94
3	Русский язык / Russian language		
	4		100
4	Extra project (optional) Time as household resource (participation of work life balance)		
5	Extra project		
6	Итого		
		8	294

Проректор/Vice Rector

Директор ДМОП/Director of the DIEP

Рег. номер/Reg. number 33 18 -04/4/102



application@urfu.ru

TRUE COPY
 Vishwanath's (IMEET)



**Уральский
Федеральный
университет**

имени первого Президента
России Б. Н. Ельцина

Милан Лалит Дандекар и все члены образования Российской Федерации
Федеральное государственное образовательное учреждение высшего
образования «Уральский федеральный университет»
имени первого Президента России Б. Н. Ельцина» (УФУ)

ул. Мира 19, Екатеринбург 620002
Факс: +7 (343) 375-93-78, тел: +7 (343) 374-38-84
контакт-центр: +7 (343) 375-44-44, 8-800-100-50-44 (звонок бесплатный)
e-mail: rector@urfu.ru, www.urfu.ru
ОКПО 027069208, ОГРН 1026604939855, ИНН/КПП: 666000/666001001

24.07.2019 № 33/18.66/53

№ _____ от _____

Reference letter

To whom it may concern,

Hereby we would like to confirm that Milan Lalit Dandekar was one of the brightest students of Summer Training Program 2019 at Ural Federal University, Yekaterinburg, Russia. During the training program, he developed the projects named Reinforced concrete structures of public buildings. He managed his free time as household resource (maintenance of work-life-balance). We found him to be a hard-working and assiduous student, who excelled at most activities in which he was taking

part. He is a well-versed, enthusiastic and promising student. His respectful and polite nature made him different from all others. Within the program, he actively participated in different extra-activities, such as:

- ✓ Malahit school (July 1 – 4, AI, ML, data Analysis work-shops from international experts);
- ✓ Ideathone 2019 (July 8 – 10, an international student engineering competition for 3 days, with tasks from real companies of Ural Region);
- ✓ Practices in inter-regional Center of Skills (industrial robots laboratory, material science laboratory, industrial process automation laboratory).

He always maintained an amicable attitude, which allowed him to complete successfully his project with teammates. We identify him as a self-confident person, who is highly efficient and dedicated towards his work. He kept good relationships with professors and other staff during not only training program but also when he returned to India. He is a reliable and disciplined student, who has the capacity of adapting himself to new and challenging environments.

You may contact Director of the Department of International education programs Mrs. Lana Vysotskaia (Aymasheva) at 8 (343) 375-93-59 if you have any questions or require additional information.

Vice-rector for academic affairs



[Handwritten signature]

Sergey T. Knyazev

TRUE COPY

[Handwritten signature]
Principal
Vishwanathar's (RMCET)

СЕРТИФИКАТ CERTIFICATE

Настоящим удостоверяется, что/
It is hereby certified that

Siddhant Sanjay Mhatre
Сиддхант Санджай Мхатре

с/from 17 Июня / June 2019

по/to 26 Июля / July 2019

прошел(ла) обучение по программе/
attended the internship in the field of:

Строительство / Civil engineering

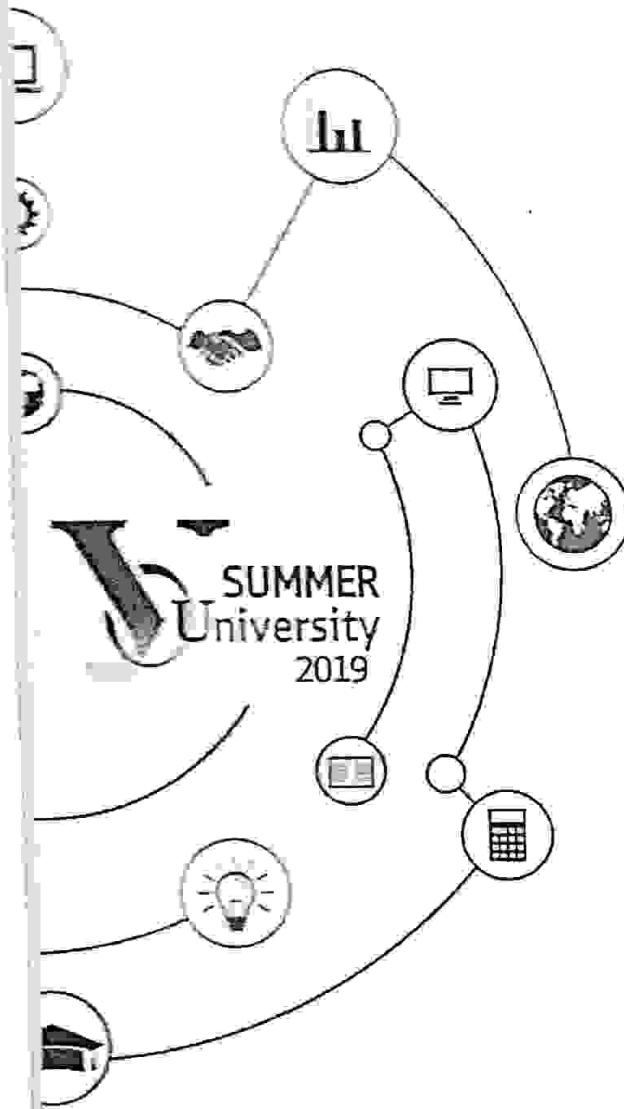

№	Модуль образовательной программы/ Educational program module		
	Академ. часы/ Academic	З.е./ECTS	Балл (%) / Grade (%)
1	Общая инженерия / Common engineering course		
	20	2	100
2	Проект: / Project work: Steel structures of industrial or public building		
	72	6	90
3	Русский язык / Russian language		
	4		100
4	Extra project (optional): HRM		
	-	-	-
5	Extra project (optional):		
6	Extra project (optional):		
	Итого/Totally		
	96	8	290

Проректор / Vice-Rector

Директор ДМОП / Director of the DIEP

Рег. номер / Reg. number

18-04/4/124



TRUE COPY

application@urfu.ru

№ 07.2019 № 33 от 06/05/19
на № _____ от _____

Reference letter

To whom it may concern,

Hereby we would like to confirm that Siddhant Sanjay Mhatre was one of the brightest students of Summer Training Program 2019 at Ural Federal University, Yekaterinburg, Russia. During his training program, he developed the projects named Steel structures of industrial or public building, HRM. We found him to be an active and assiduous student, who excelled at most activities in which he was taking part.

He is well versed, enthusiastic and promising student. His respectful and polite nature made him different from all others. Within the program, he actively participated in different extra-activities, such as:

- ✓ Malahit school (July 1 – 4, AI, ML, data Analysis work-shops from international experts);
- ✓ Ideathone 2019 (July 8 – 10, an international student engineering competition for 3 days, with tasks from real companies of Ural Region);
- ✓ Practices in inter-regional Center of Skills (industrial robots laboratory, material science laboratory, industrial process automation laboratory).

He always maintained an amicable attitude, which allowed him to complete successfully his project with teammates. We identify him as a self-confident person, who is highly efficient and dedicated towards his work. He kept good relationships with professors and other staff during not only training program but also when he returned to India. He is a reliable and disciplined student, who has the capacity of adapting himself to new and challenging environments.

You may contact Director of the Department of International education programs Mrs. Iana Vysotskaia (Aymasheva) at 8 (343) 375-93-59 if you have any questions or require additional information.

Vice-rector for academic affairs



Sergey T.Knyazev

TRUE COPY

Siddhant
Vishwanathan's (IMEET)



Ural Federal University

named after the first President of Russia B.N.Yeltsin

ФГАОУ ВО «Уральский федеральный университет им. первого Президента России Б. Н. Ельцина»
Department of International Educational programs

СЕРТИФИКАТ CERTIFICATE

Настоящим сертификатом удостоверяется, что/
It is hereby certified that

Thool Kushal Prabhakar
Тул Кушал Прабхакар

с/From 20 июля/July 2015
по/to 30 июля/July 2015
пришел(ла) обучению по курсу/трамме/
attended the course of

Проектирование металлических и железобетонных конструкций
Design of steel and reinforced concrete structures

№	Educational program module/ Модуль образовательной программы		
	Academic hours/ Академ.часы	ECTS/З.е.	Grade (%)/ Балл (%)
1	28	3	98
2	42	5	98
3	12	1	98
4	18	1	98
5	36	3	98

TRUE COPY

(Signature)
Vice-Rector

application@urfu.ru

Проректор/Vice-Rector

Директор ДМОП/Director of the DEEP

Reg. номер/Reg. number



Scanned by CamScanner

UNLV | HOWARD R. HUGHES
COLLEGE OF
ENGINEERING

*Certificate of Completion of the Engineering
Global Internship Program*

This is to certify that

Shreemay Sanjay Narvekar

has successfully completed 6 weeks of the global internship

program from June 18, 2019 – July 26, 2019



Jaekeun Cho, Director
Howard R. Hughes College of Engineering
International Programs

07/26/2019

Date

TRUE COPY

Principal
Vighwan Chandra's (IMEET)





CERTIFICATE OF APPRECIATION

Athens Information Technology

certifies that

Sneha Patil

supervised the

**UG Fellowship Summer Project and Research Program under the
CTIF – Vishwaniketan – GISFI Network**

held in Athens from June 20, 2019 to July 25, 2019

Her dedicated efforts were instrumental to the successful completion of the program

Constantinos Papadias
Scientific Director

TRUE COPY
Vishwaniketan (AMCET)

Sofoklis Efremidis
Program Director

IndiaFIRST® ROBOTICS

IndiaFIRST®
ROBOTICS

This is to certify that

Niraj Mali

has successfully completed an excited and innovation STEN program (On-Job training) on

Drone Technology with Grade *A*

and has been awarded *Jr. Flying Engineer*

We wish him/her a successful career in
Science, Technology, Engineering & Mathematics in future.

Date *25.09.2020* Location *VIMEET*

Certificate No. *20202192*

Vinay Kunwar
Founder-Director
IndiaFIRST® Robotics,
Pune

IndiaFIRST®
ROBOTICS

TRUE COPY

Vinay Kunwar
Vishwanath's (VIMEET)

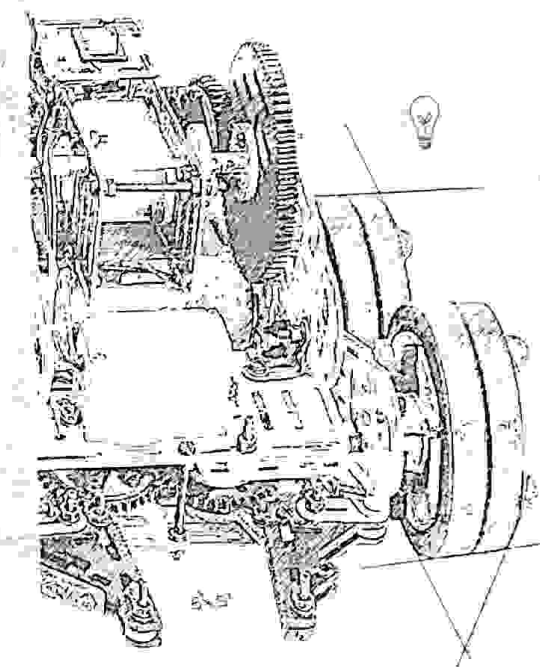

IndiaFIRST[®]ROBOTICS

This is to certify that

Rishika Negi

has successfully completed an excited and innovation STEN program (On-Job training) on

Drone Technology with Grade *A*

and has been awarded *Jr. Flying Engineer*

We wish him/her a successful career in
Science, Technology, Engineering & Mathematics in future.

Date *25.09.2020* Location *VIMEET*

Certificate No. *20202185*

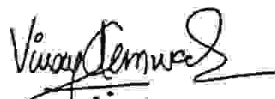
Vinay Kunwar
Founder-Director
IndiaFIRST[®] Robotics,
Pune

IndiaFIRST[®]
ROBOTICS



IndiaFIRST[®]
ROBOTICS

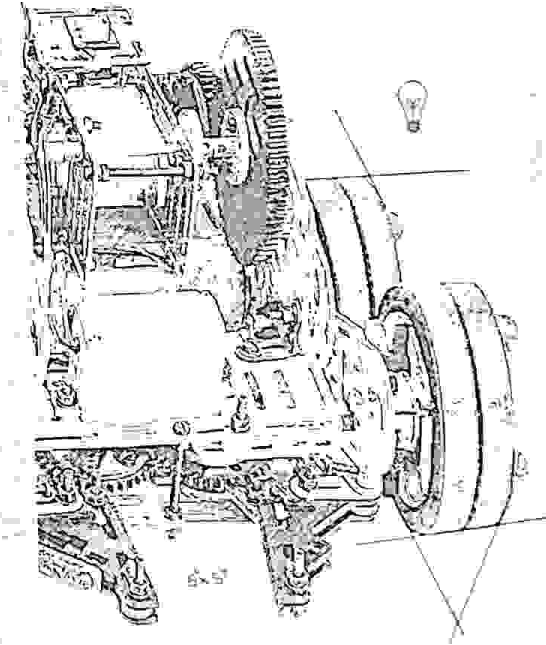

IndiaFIRST® ROBOTICS

This is to certify that

Ritika singh

has successfully completed an excited and innovation STEN program (On-Job training) on

Drone Technology with Grade ***A***

and has been awarded ***Jr. Flying Engineer***

We wish him/her a successful career in
Science, Technology, Engineering & Mathematics in future

Date ***25.09.2020*** Location ***VIMEET***

Certificate No. ***20202177***

Vinay Kunwar
Founder Director
IndiaFIRST® Robotics,
Pune

IndiaFIRST®
ROBOTICS

TRUE COPY

Vishwanath S. S. (IASEET)

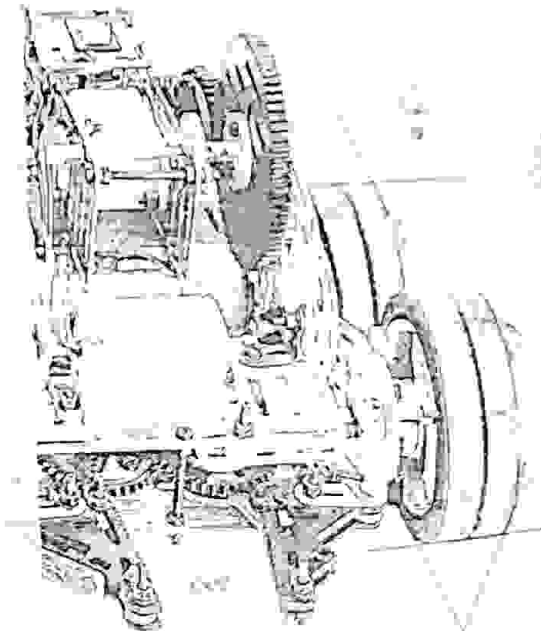



DNYANDA SUSTAINABLE ENGINEERING SOLUTIONS (DSES) PRIVATE LIMITED, PUNE

A Sustainable Development Venture

 dses.contact@gmail.com

 RNO74/5FLA/104, Pune (MS) India - 412101

 www.dnyandses.com

CERTIFICATE

This is to certify that

Bhawke Omkar Bajarang

Has successfully completed the On-Job training in

ARDUINO

From Jan 2020 to May 2020



Vasudha Dnyanam Eshwaram

Vikas Shinde

Dr. Vikas Shinde
Director



DNYANDA SUSTAINABLE ENGINEERING SOLUTIONS (DSES) PRIVATE LIMITED, PUNE

A Sustainable Development Venture

✉ dses.contact@gmail.com

📍 RND74/SFLA/104, Pune (MS) India - 412101

🌐 www.dnyandses.com

CERTIFICATE

This is to certify that

Mhatre Arunat

Has successfully completed the On-Job training in

ARDUINO

TRUE COPY

From **Jan 2020** to **May 2020**



Vasudha Dnyanam Eshwaram

[Handwritten Signature]
VND/MS/104/1007

[Handwritten Signature]

Dr. Vikas Shinde
Director



DNYANDA SUSTAINABLE ENGINEERING SOLUTIONS (DSES) PRIVATE LIMITED, PUNE

A Sustainable Development Venture

✉ dses.contact@gmail.com

📍 RNO74/5FLA/104, Pune (MS) India - 412101.

🌐 www.dnyandes.com

CERTIFICATE

This is to certify that

Vitkar Atharva Prasad

Has successfully completed the On-Job training in

ARDUINO

From **Jan 2020** to **May 2020**



Vasudha Dnyanam Eshwaram

Vikas Shinde

Dr. Vikas Shinde
Director

BITC
2104



Automation for life simplification

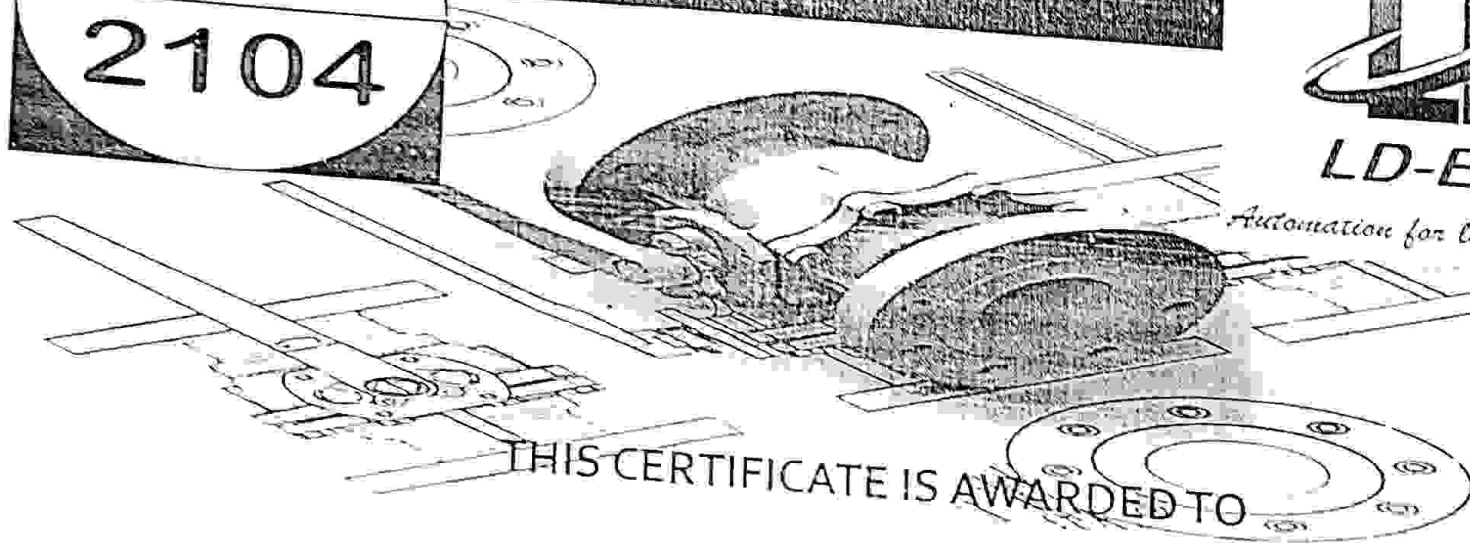

THIS CERTIFICATE IS AWARDED TO

AVINASH DAREKAR

WHO HAS SUCCESSFULLY COMPLETED ON-JOB TRAINING
ON

PLC & SCADA

DATED FROM
JAN 13 2020 TO JAN 18 2020

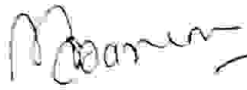
Mr. O.N. Barure
DIRECTOR

TRUE COPY



Creativity through understanding fundamentals

BITC
2104



LD-Engg

Automation for life simplification

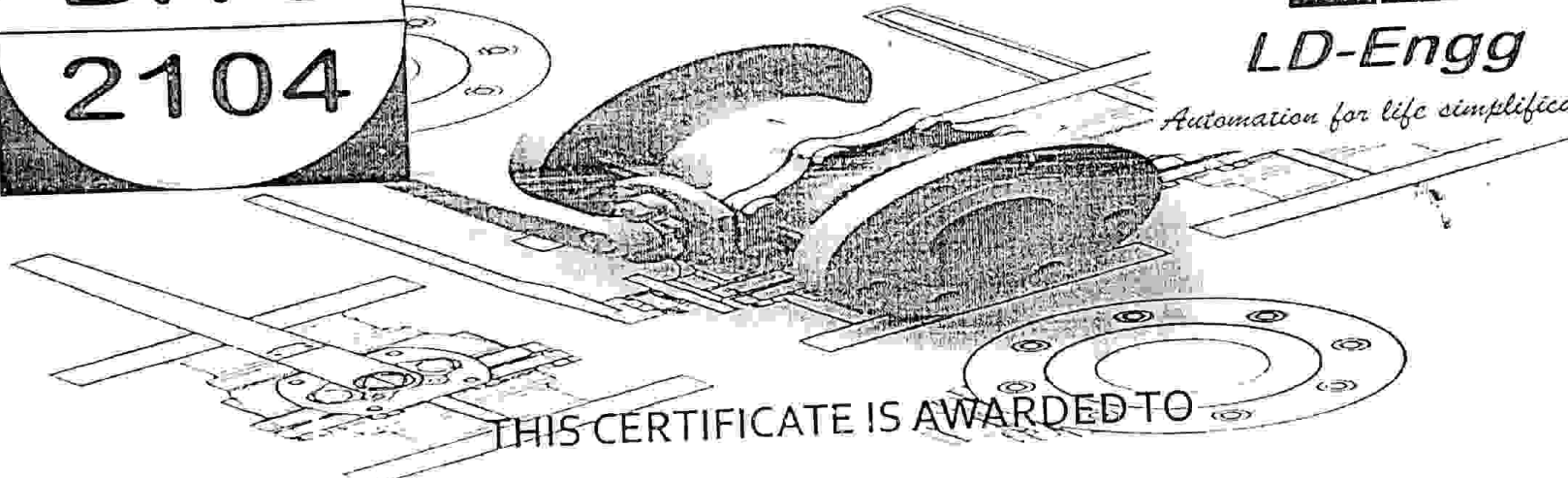

THIS CERTIFICATE IS AWARDED TO

OMKAR CHAVAN,

WHO HAS SUCCESSFULLY COMPLETED ON-JOB TRAINING
ON

PLC & SCADA

DATED FROM

JAN 13 2020 TO JAN 18 2020

Mr. O.N. Barure

Mr. O.N. Barure
DIRECTOR

Creativity through understanding fundamentals

BITC
2104



LD-Engg

Automation for life simplification

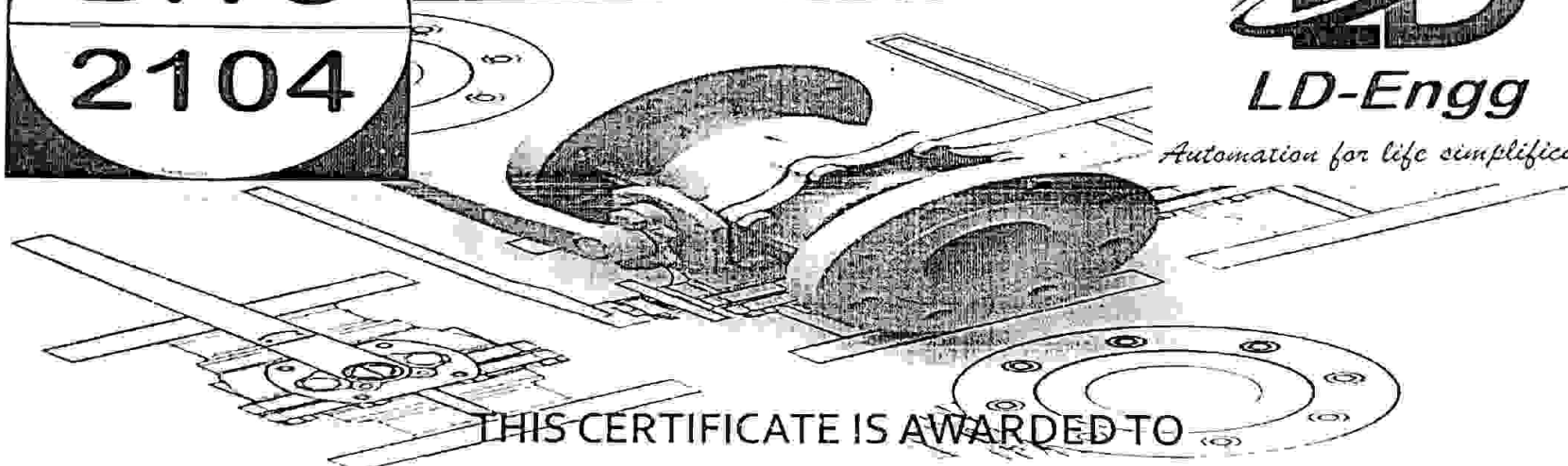

THIS CERTIFICATE IS AWARDED TO

AKASH BANGAR

WHO HAS SUCCESSFULLY COMPLETED ON-JOB TRAINING
ON

PLC & SCADA

DATED FROM
JAN 13 2020 TO JAN 18 2020

TRUE COPY

Mr. O.N. Barure
DIRECTOR

Vishwa... (10.0.57)

Creativity through understanding fundamentals

BITC
2104



Automation for life simplification

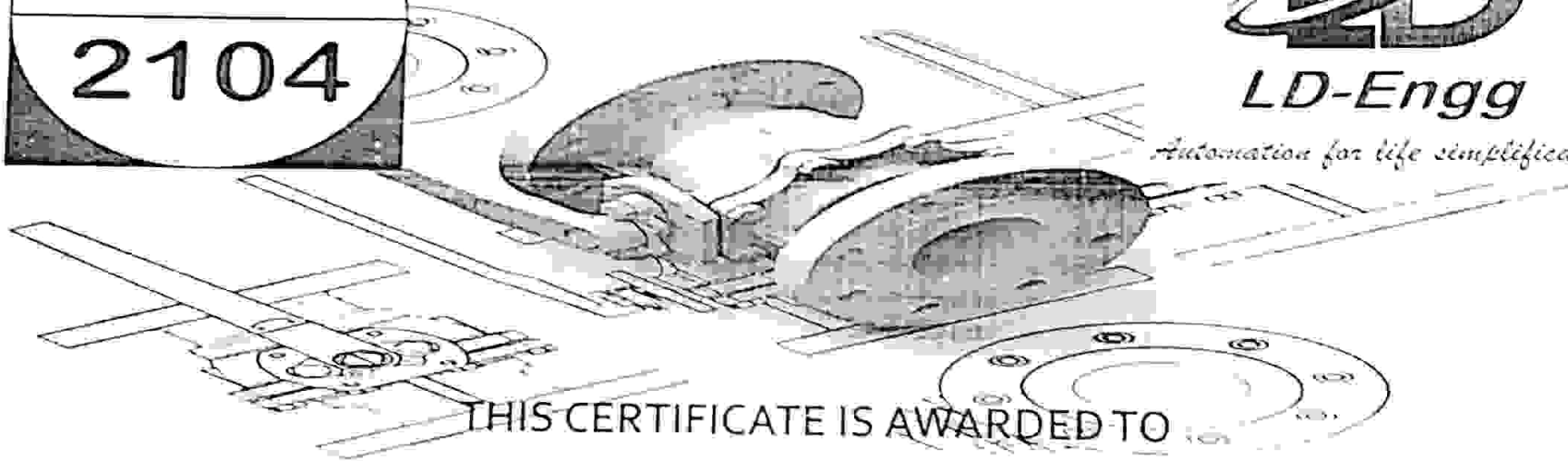

THIS CERTIFICATE IS AWARDED TO

NISHANT MORAL

WHO HAS SUCCESSFULLY COMPLETED ON-JOB TRAINING
ON

PLC & SCADA

DATED FROM

JAN 13 2020 TO JAN 18 2020

TRUE COPY

A handwritten signature in black ink, appearing to read 'O.N. Barure'.

Mr. O.N. Barure
DIRECTOR

Creativity through understanding fundamentals

BITC
2104



Automation for life simplification



THIS CERTIFICATE IS AWARDED TO

KARUNANAND MISHRA

WHO HAS SUCCESSFULLY COMPLETED ON-JOB TRAINING
ON

PLC & SCADA

DATED FROM

JAN 13 2020 TO JAN 18 2020

TRUE COPY

A handwritten signature in black ink, appearing to read 'O.N. Barure'.

Mr. O.N. Barure
DIRECTOR

Creativity through understanding fundamentals

BITC
2104



LD-Engg

Automation for life simplification

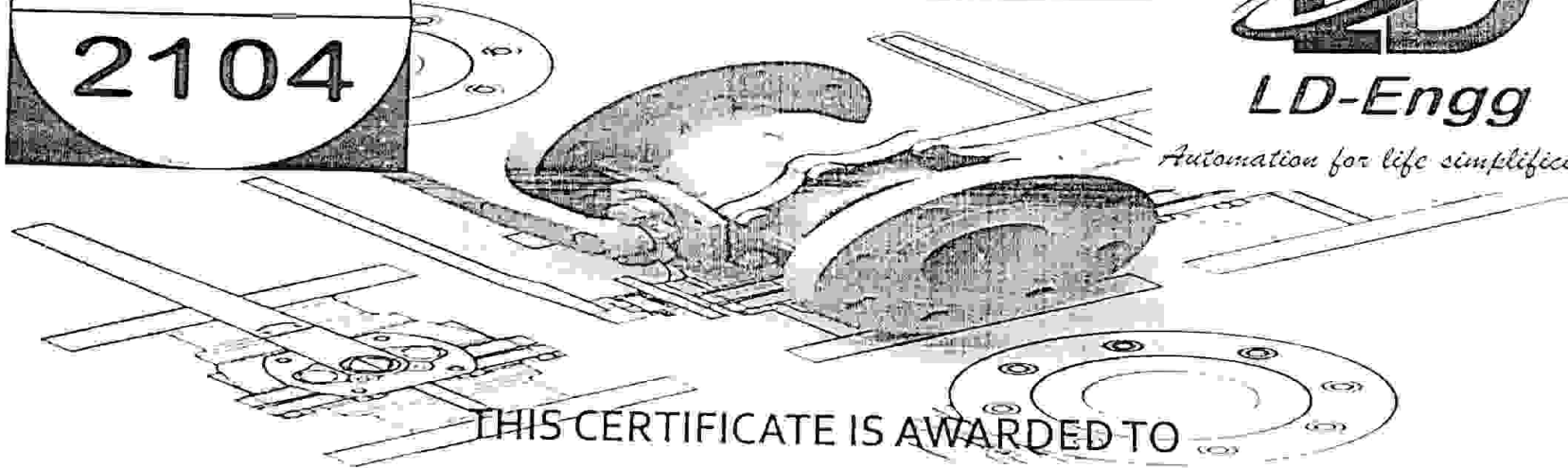

THIS CERTIFICATE IS AWARDED TO

DIKSHA MHATRE.

WHO HAS SUCCESSFULLY COMPLETED ON-JOB TRAINING
ON

PLC & SCADA

DATED FROM

JAN 13 2020 TO JAN 18 2020

Mr. O.N. Barure
DIRECTOR

TRUE COPY

Creativity through understanding fundamentals

BITC
2104



LD-Engg

Automation for life simplification

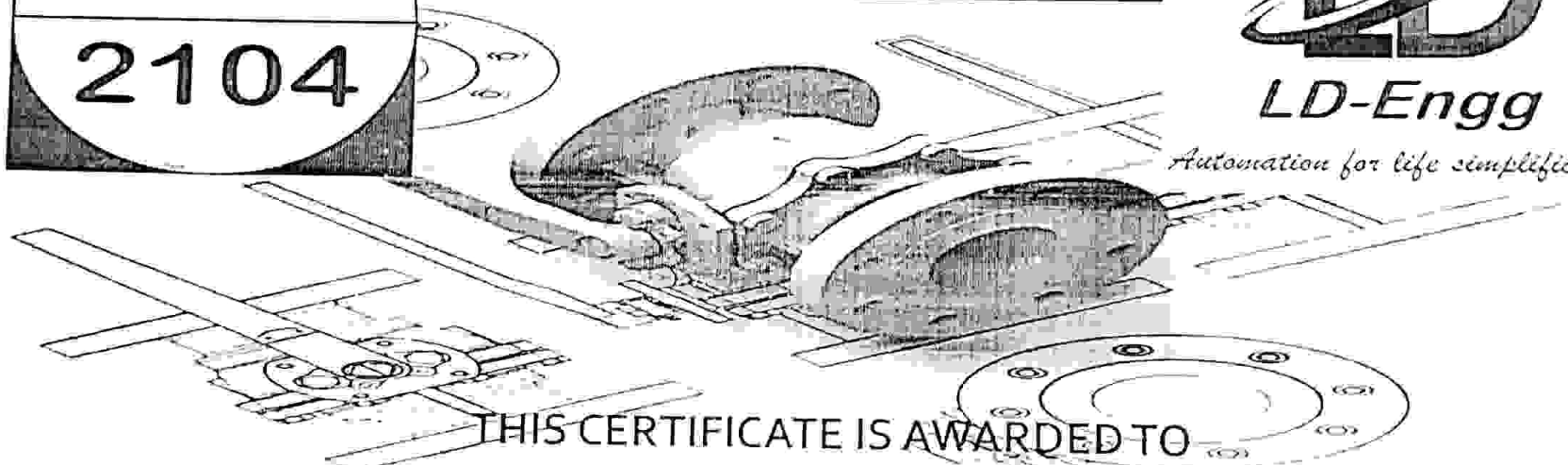

THIS CERTIFICATE IS AWARDED TO

SAGAR KASARE

WHO HAS SUCCESSFULLY COMPLETED ON-JOB TRAINING
ON

PLC & SCADA

DATED FROM

JAN 13 2020 TO JAN 18 2020

TRUE COPY

A handwritten signature in black ink, appearing to read 'O.N. Barure'.

Mr. O.N. Barure
DIRECTOR

Creativity through understanding fundamentals

BITC
2104



Automation for life simplification

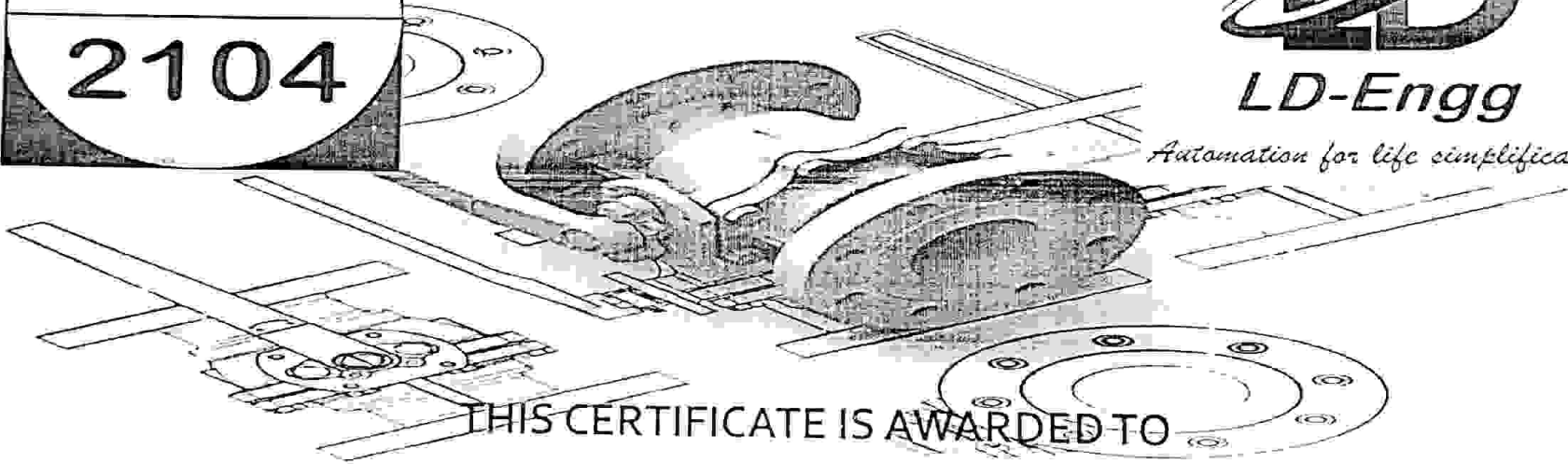

THIS CERTIFICATE IS AWARDED TO

MAJOR JADHAV

WHO HAS SUCCESSFULLY COMPLETED ON-JOB TRAINING
ON

PLC & SCADA

DATED FROM

JAN 13 2020 TO JAN 18 2020

A handwritten signature in black ink, appearing to read 'Mr. O.N. Barure', with a flourish at the end.

Mr. O.N. Barure
DIRECTOR

Creativity through understanding fundamentals

BITC
2104



LD-Engg

Automation for life simplification

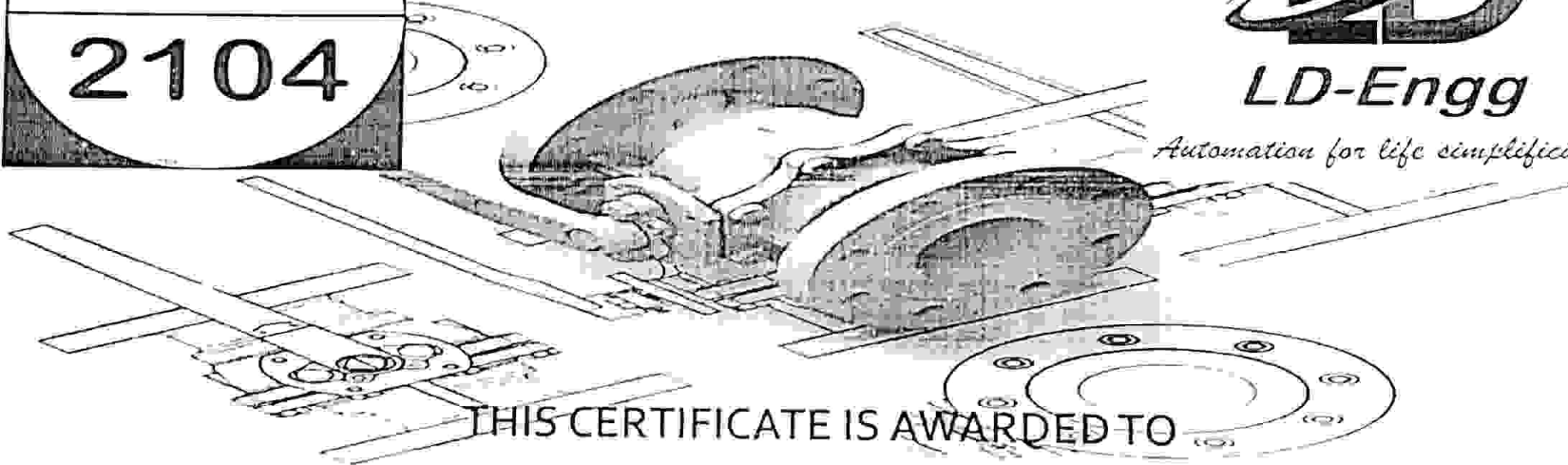

THIS CERTIFICATE IS AWARDED TO

SURAJ HUKR.

WHO HAS SUCCESSFULLY COMPLETED ON-JOB TRAINING
ON

PLC & SCADA

DATED FROM

JAN 13 2020 TO JAN 18 2020

TRUE COPY

Mr. O.N. Barure

DIRECTOR

Creativity through understanding fundamentals

BITC
2104



LD-Engg

Automation for life simplification



THIS CERTIFICATE IS AWARDED TO

AMIT GHANVAT.

WHO HAS SUCCESSFULLY COMPLETED ON-JOB TRAINING
ON

PLC & SCADA

DATED FROM

JAN 13 2020 TO JAN 18 2020

Mr. O.N. Barure
DIRECTOR

Creativity through understanding fundamentals

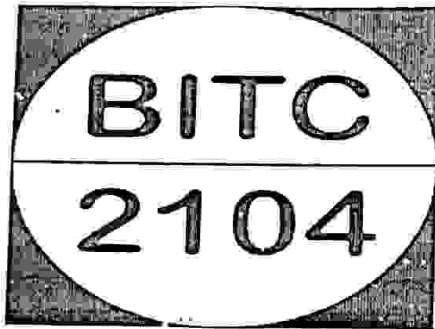

Automation for life simplification

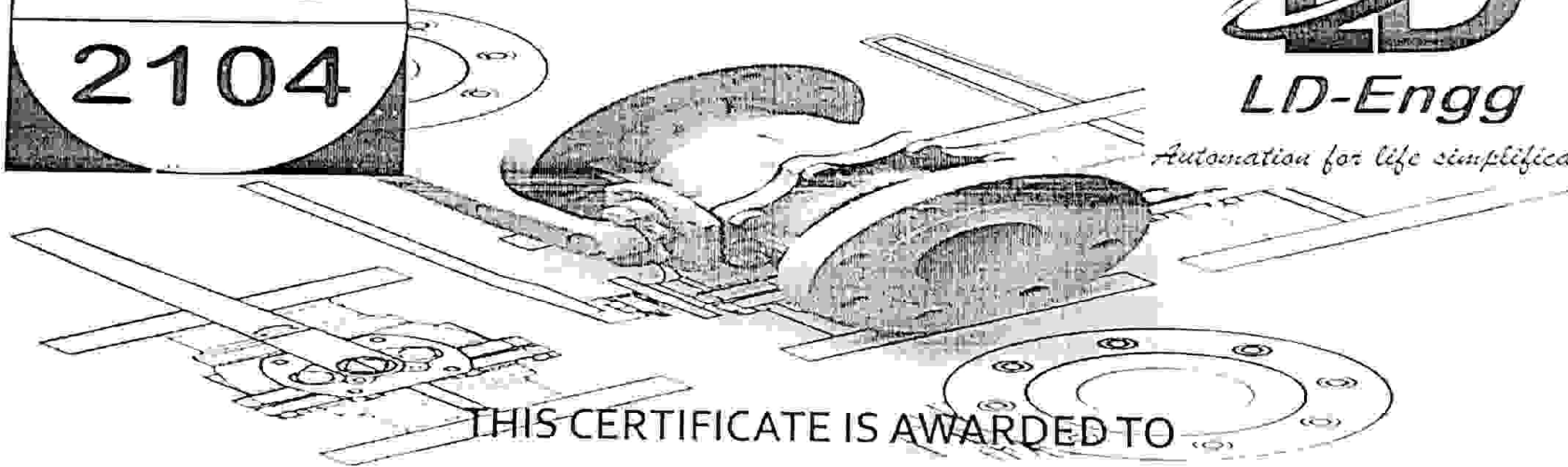

THIS CERTIFICATE IS AWARDED TO

ABHIJEET GHORPADE.

WHO HAS SUCCESSFULLY COMPLETED ON-JOB TRAINING
ON

PLC & SCADA

DATED FROM

JAN 13 2020 TO JAN 18 2020

TRUE COPY

[Handwritten signature]

Mr. O.N.Barure
DIRECTOR

Creativity through understanding fundamentals

BITC
2104

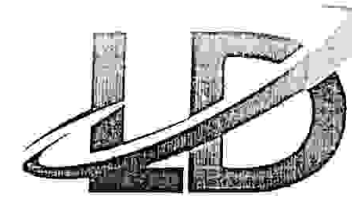

LD-Engg

Automation for life simplification

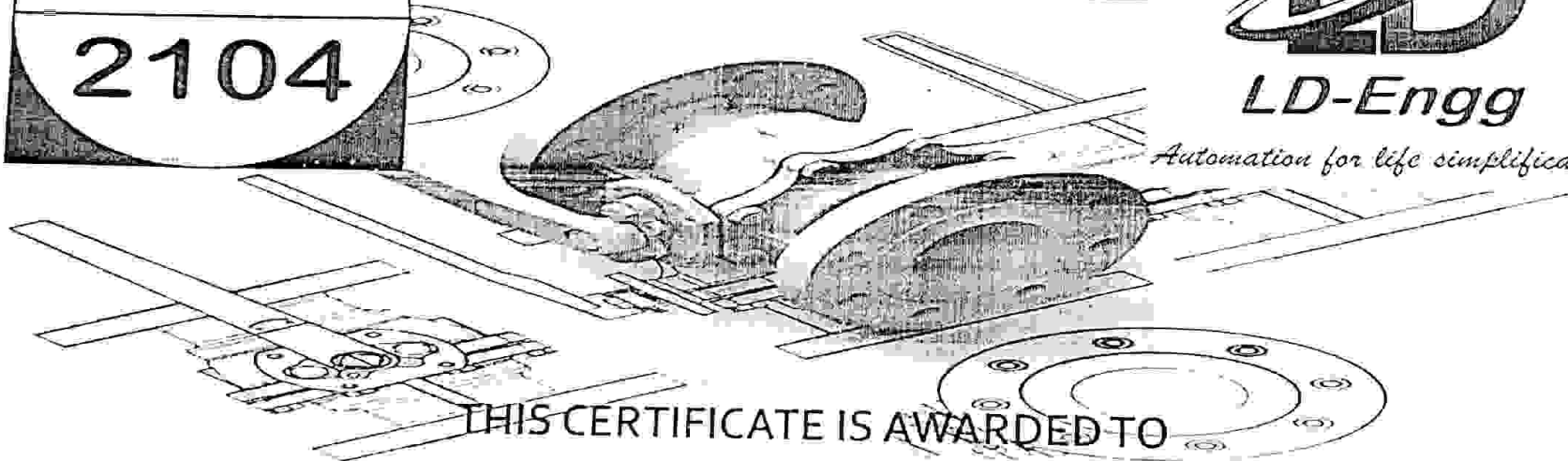

THIS CERTIFICATE IS AWARDED TO

VIJAY GAIKWAD.

WHO HAS SUCCESSFULLY COMPLETED ON-JOB TRAINING
ON

PLC & SCADA

DATED FROM

JAN 13 2020 TO JAN 18 2020

TRUE COPY

Principal
Vishwanathrao's (WASET)

Mr. O.N.Barure
DIRECTOR

Creativity through understanding fundamentals

BITC
2104



LD-Engg

Automation for life simplification

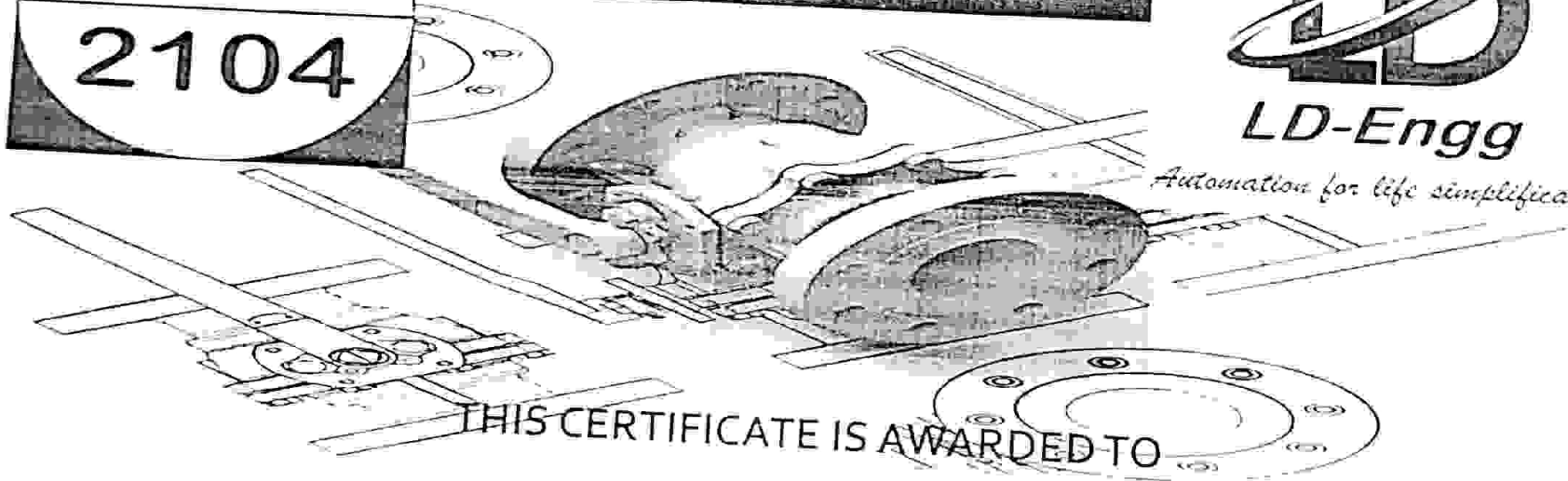

THIS CERTIFICATE IS AWARDED TO

SWARNIL DHAPATE,

WHO HAS SUCCESSFULLY COMPLETED ON-JOB TRAINING
ON

PLC & SCADA

DATED FROM

JAN 13 2020 TO JAN 18 2020

TRUE COPY

A handwritten signature in black ink, appearing to read 'O.N. Barure'.

Mr. O.N. Barure
DIRECTOR

Creativity through understanding fundamentals

BITC
2104



LD-Engg

Automation for life simplification

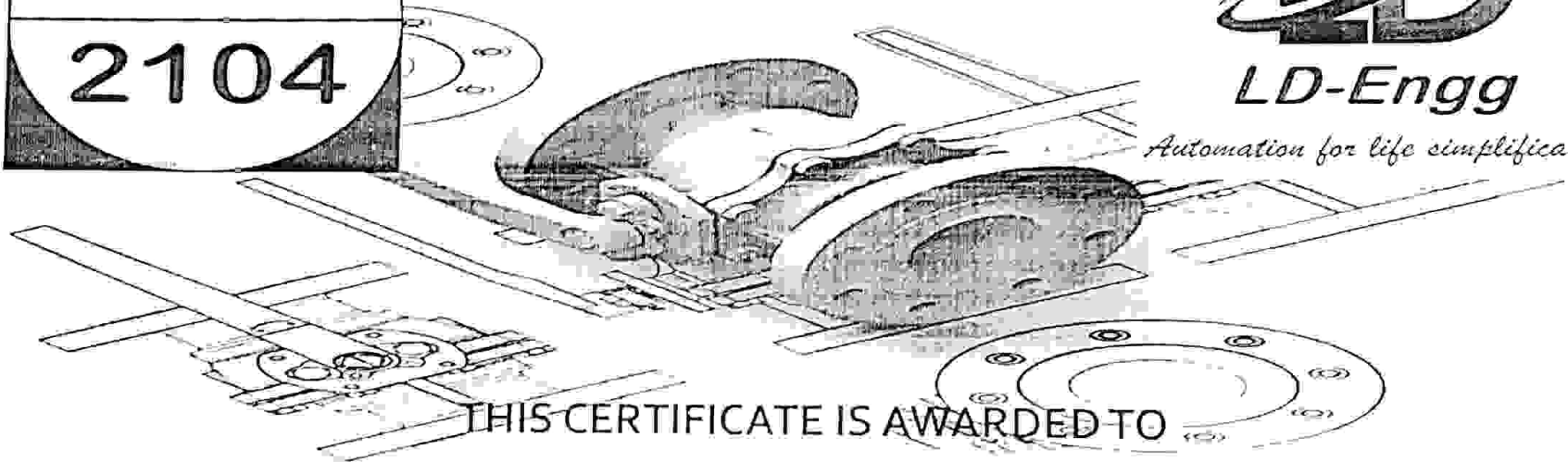

THIS CERTIFICATE IS AWARDED TO

TUSHAR DESHMUKH

WHO HAS SUCCESSFULLY COMPLETED ON-JOB TRAINING
ON

PLC & SCADA

DATED FROM

JAN 13 2020 TO JAN 18 2020

TRUE COPY

O.N. Barure

[Signature]
DIRECTOR

Mr. O.N. Barure

DIRECTOR

Creativity through understanding fundamentals

BITC
2104



LD-Engg

Automation for life simplification

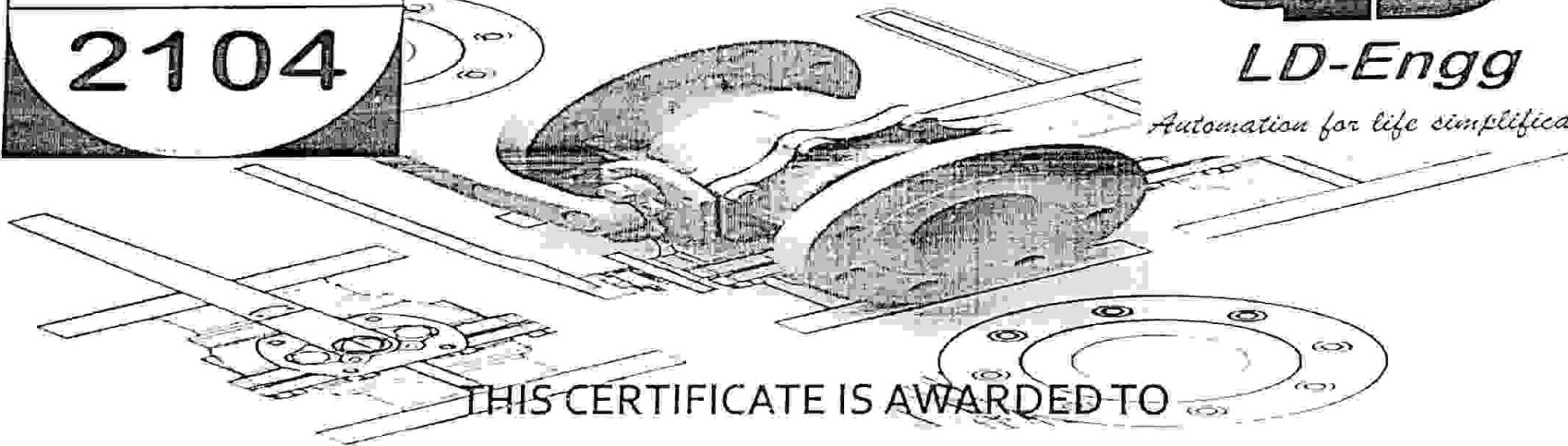

THIS CERTIFICATE IS AWARDED TO

VAJIBHAV PARTHE.

WHO HAS SUCCESSFULLY COMPLETED ON-JOB TRAINING
ON

PLC & SCADA

DATED FROM

JAN 13 2020 TO JAN 18 2020

TRUE COPY

Mr. O.N. Barure
O.N. Barure (DIRECTOR)

Mr. O.N. Barure
DIRECTOR

Creativity through understanding fundamentals

BITC
2104

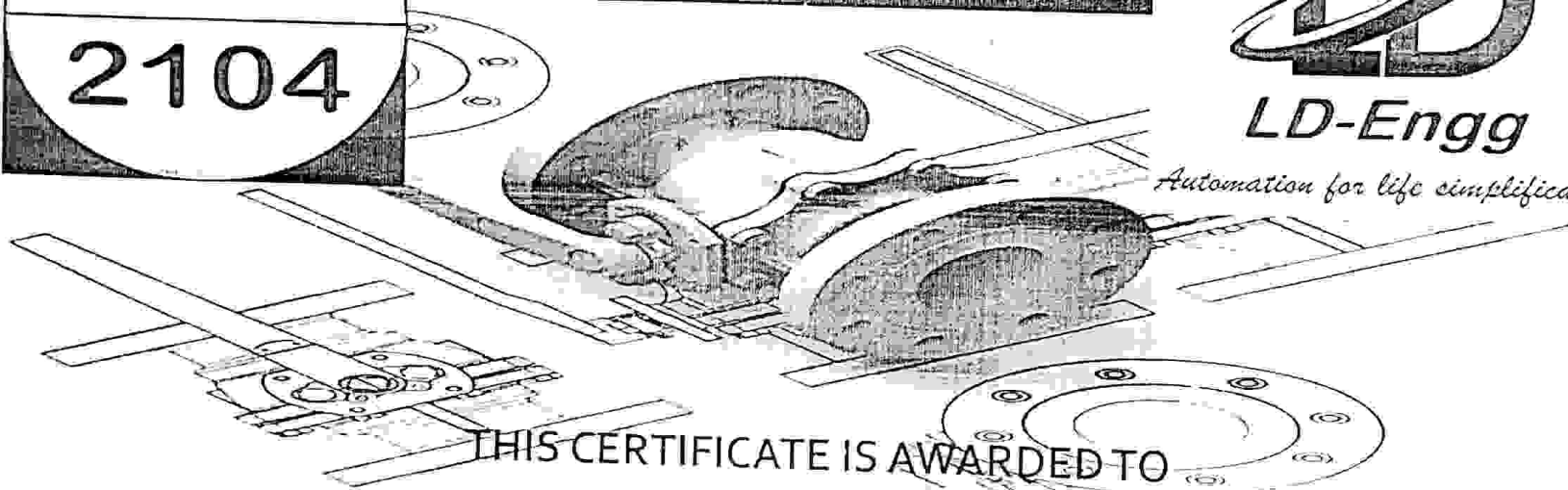

THIS CERTIFICATE IS AWARDED TO

DARSHAN PATHARE

WHO HAS SUCCESSFULLY COMPLETED ON-JOB TRAINING
ON

PLC & SCADA

DATED FROM

JAN 13 2020 TO JAN 18 2020

TRUE COPY

A handwritten signature in black ink, appearing to read 'O.N. Barure'.

Mr. O.N. Barure
DIRECTOR

A logo for 'Vishwani' featuring a stylized 'V' and 'W' intertwined, with the word 'Vishwani' written below it.

Creativity through understanding fundamentals

BITC
2104

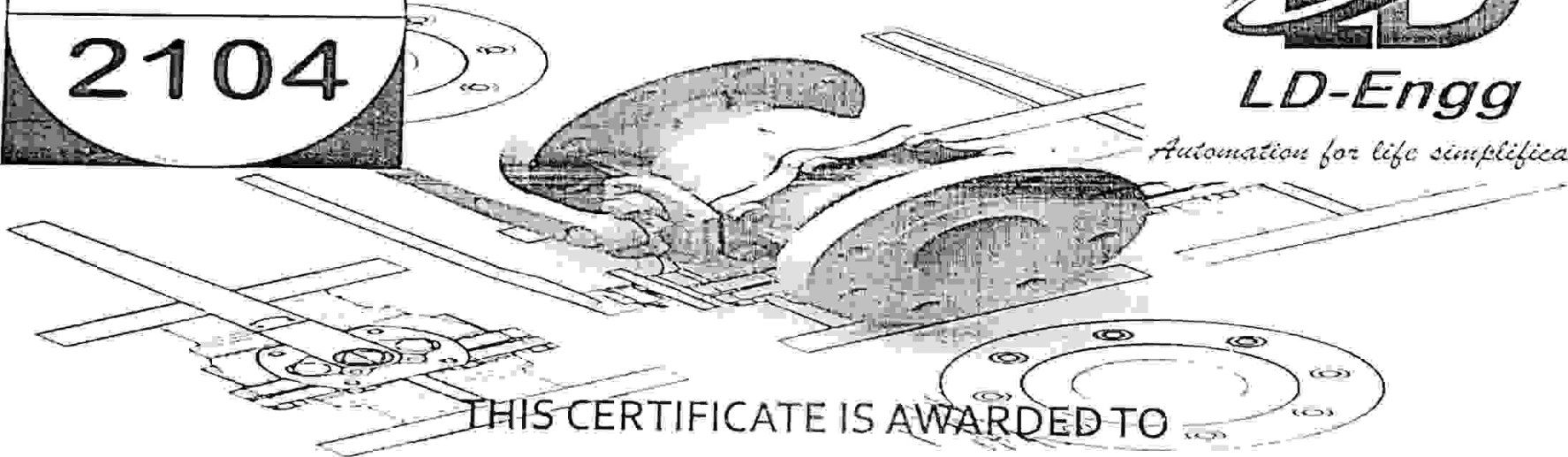

THIS CERTIFICATE IS AWARDED TO

AJAY PATIL

WHO HAS SUCCESSFULLY COMPLETED ON-JOB TRAINING
ON

PLC & SCADA

DATED FROM

JAN 13 2020 TO JAN 18 2020

TRUE COPY

O.N. Barure
Director

Mr. O.N.Barure
DIRECTOR

Creativity through understanding fundamentals

BITC
2104



Automation for life simplification



THIS CERTIFICATE IS AWARDED TO

ASMIT PATIL

WHO HAS SUCCESSFULLY COMPLETED ON-JOB TRAINING
ON

PLC & SCADA

DATED FROM

JAN 13 2020 TO JAN 18 2020

TRUE COPY

A handwritten signature in black ink, appearing to read 'O.N. Barure', written over a faint stamp.

Mr. O.N. Barure
DIRECTOR

Creativity through understanding fundamentals

BITC
2104



LD-Engg

Automation for life simplification



THIS CERTIFICATE IS AWARDED TO

HARSHAL PATIL,

WHO HAS SUCCESSFULLY COMPLETED ON-JOB TRAINING
ON

PLC & SCADA

DATED FROM

JAN 13 2020 TO JAN 18 2020

Mr. O.N. Barure

TRUE COPY
[Signature]

Mr. O.N. Barure
DIRECTOR

Creativity through understanding fundamentals

BITC
2104



LD-Engg

Automation for life simplification



THIS CERTIFICATE IS AWARDED TO

MAHENDRA PATIL

WHO HAS SUCCESSFULLY COMPLETED ON-JOB TRAINING
ON

PLC & SCADA

DATED FROM

JAN 13 2020 TO JAN 18 2020

TRUE COPY

Mr. O.N. Barure

Mr. O.N. Barure
DIRECTOR

Creativity through understanding fundamentals

BITC
2104



LD-Engg

Automation for life simplification

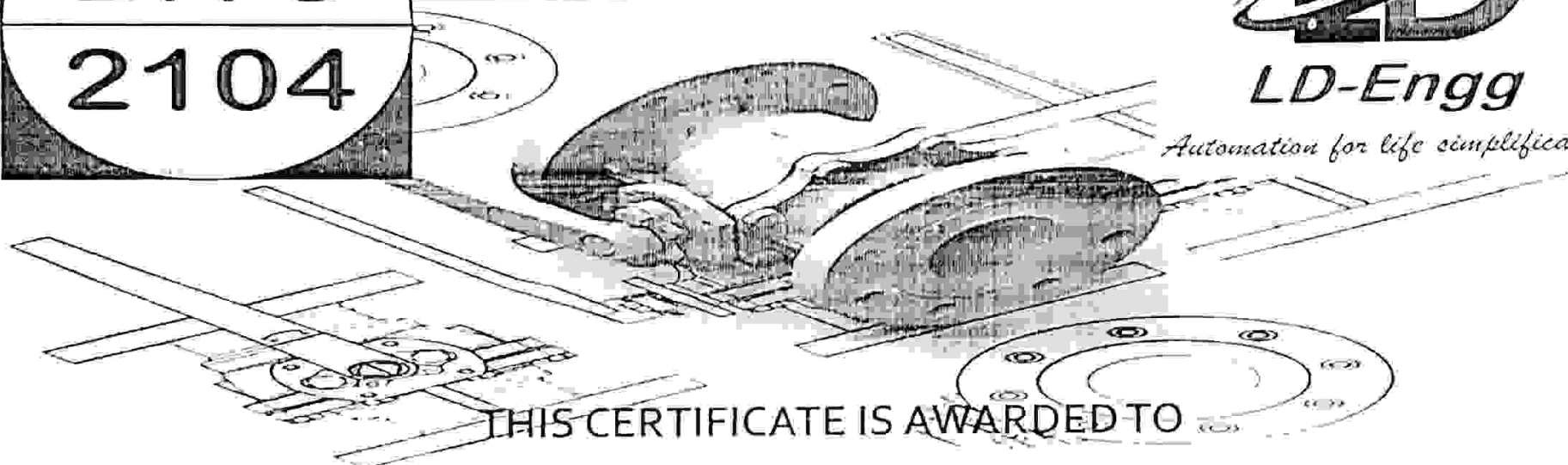

THIS CERTIFICATE IS AWARDED TO

SIDDHESH PATIL

WHO HAS SUCCESSFULLY COMPLETED ON-JOB TRAINING
ON

PLC & SCADA

DATED FROM

JAN 13 2020 TO JAN 18 2020

TRUE COPY

[Signature]
Vishw...

Mr. O.N.Barure
DIRECTOR

Creativity through understanding fundamentals

BITC
2104



LD-Engg

Automation for life simplification

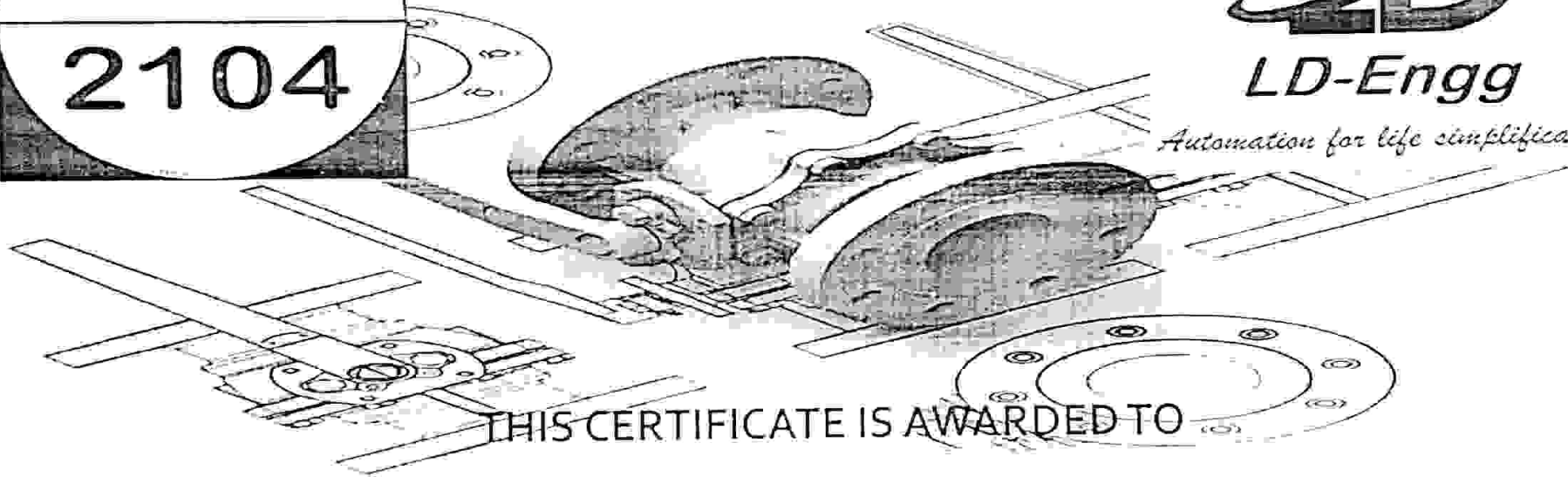

THIS CERTIFICATE IS AWARDED TO

AMEYA PHADKE

WHO HAS SUCCESSFULLY COMPLETED ON-JOB TRAINING
ON

PLC & SCADA

DATED FROM

JAN 13 2020 TO JAN 18 2020

Mr. O.N. Barure
Mr. O.N. Barure
DIRECTOR

TRUE COPY

Creativity through understanding fundamentals

BITC
2104



LD-Engg

Automation for life simplification

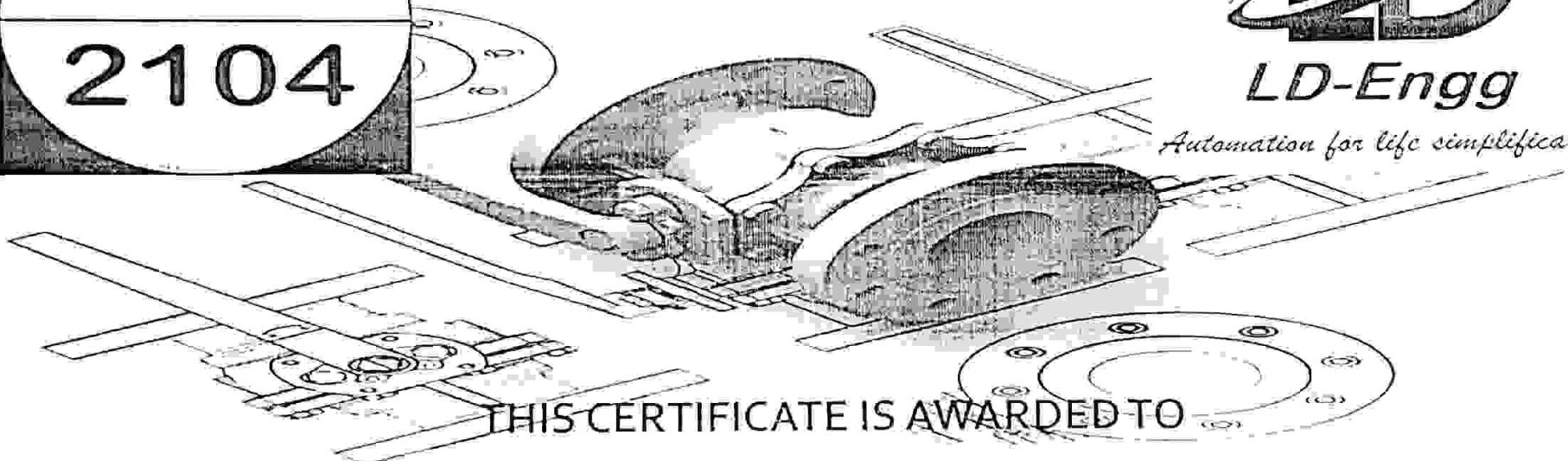

THIS CERTIFICATE IS AWARDED TO

RAVI SHELKE

WHO HAS SUCCESSFULLY COMPLETED ON-JOB TRAINING
ON

PLC & SCADA

DATED FROM

JAN 13 2020 TO JAN 18 2020

Barure TRUE COPY
Mr. O.N.Barure
DIRECTOR

Creativity through understanding fundamentals

BITC
2104



LD-Engg

Automation for life simplification

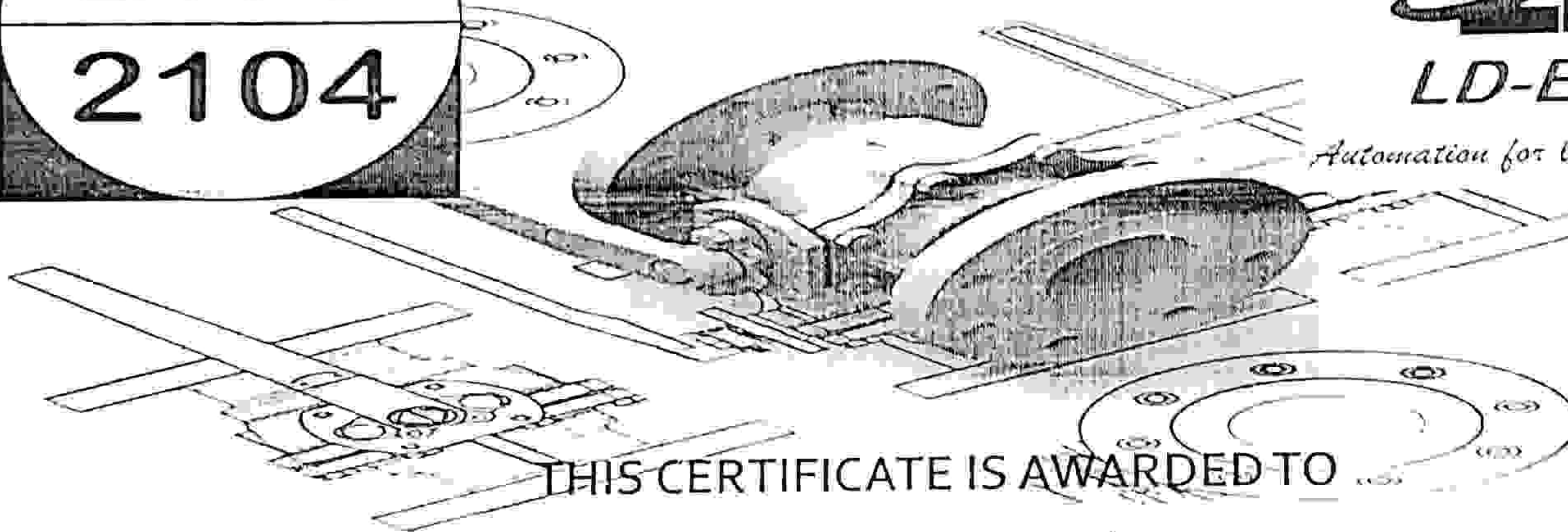

THIS CERTIFICATE IS AWARDED TO

PANKAJ TANDEL.

WHO HAS SUCCESSFULLY COMPLETED ON-JOB TRAINING
ON

PLC & SCADA

DATED FROM

JAN 13 2020 TO JAN 18 2020

O.N. Barure
Mr. O.N. Barure
DIRECTOR

TRUE COPY

Creativity through understanding fundamentals

BITC
2104



LD-Engg

Automation for life simplification



THIS CERTIFICATE IS AWARDED TO

NILESH TAYDE,

WHO HAS SUCCESSFULLY COMPLETED ON-JOB TRAINING
ON

PLC & SCADA

DATED FROM

JAN 13 2020 TO JAN 18 2020

Barure
Mr. O.N.Barure
DIRECTOR

TRUE COPY

[Signature]

Creativity through understanding fundamentals

BITC
2104



LD-Engg

Automation for life simplification



THIS CERTIFICATE IS AWARDED TO

RAHUL THAKUR

WHO HAS SUCCESSFULLY COMPLETED ON-JOB TRAINING
ON

PLC & SCADA

DATED FROM

JAN 13 2020 TO JAN 18 2020

Mr. O.N. Barure
DIRECTOR

Creativity through understanding fundamentals

BITC
2104

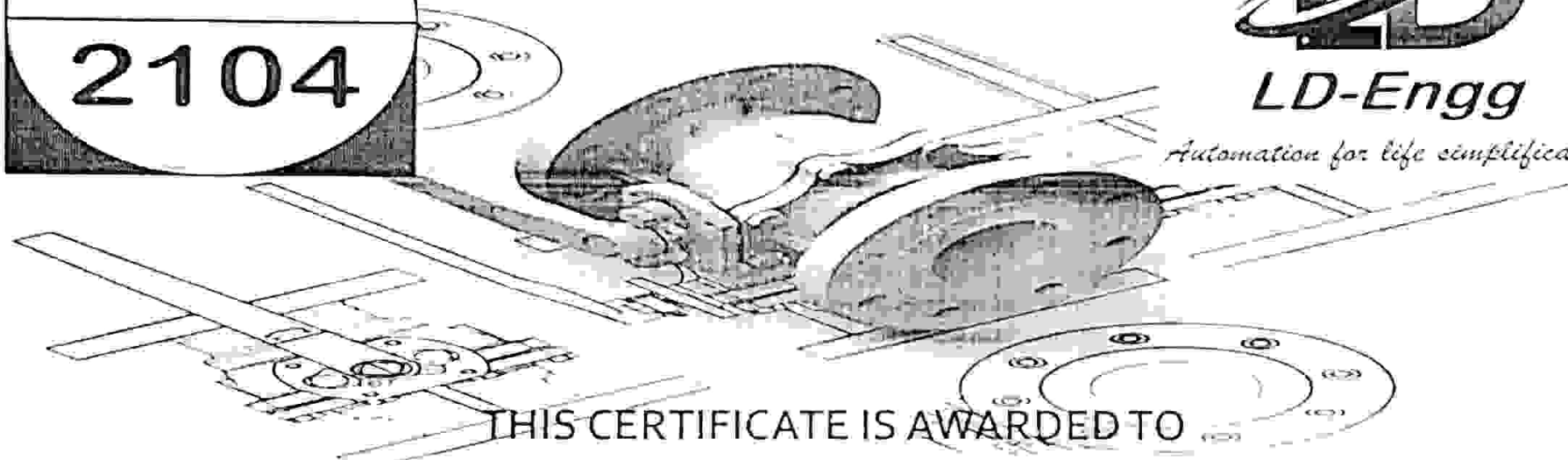

THIS CERTIFICATE IS AWARDED TO

VIPRESH TODANKAR.

WHO HAS SUCCESSFULLY COMPLETED ON-JOB TRAINING
ON

PLC & SCADA

DATED FROM

JAN 13 2020 TO JAN 18 2020

Mr. O.N. Barure
Mr. O.N. Barure
DIRECTOR

Creativity through understanding fundamentals



LD-Engg

Automation for life simplification

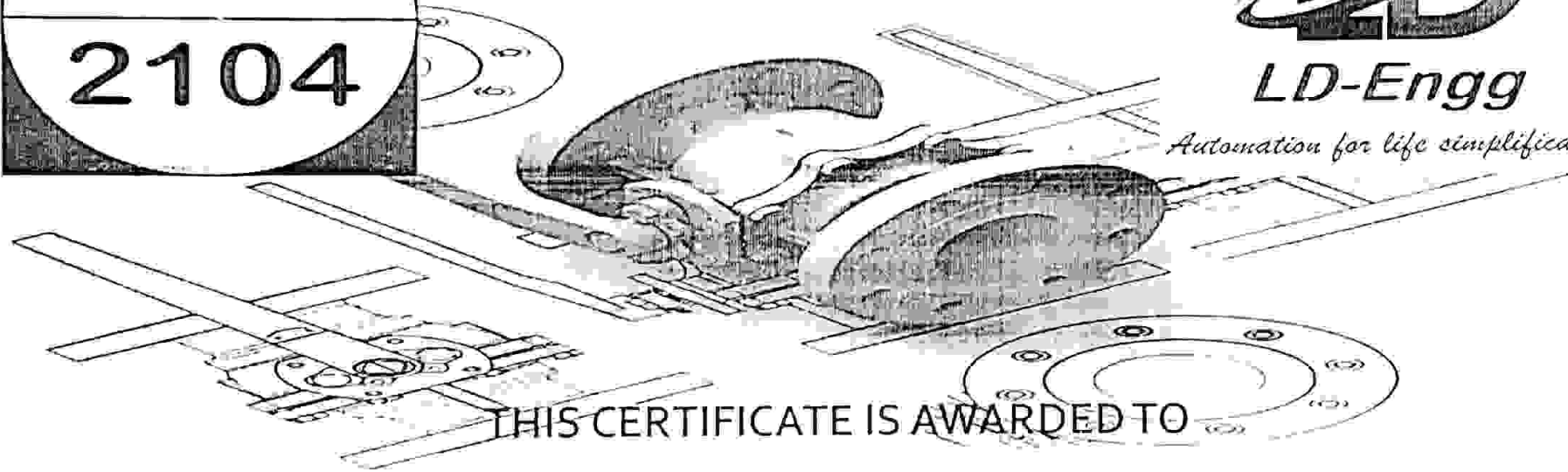

THIS CERTIFICATE IS AWARDED TO

SHREYA UBHARE.

WHO HAS SUCCESSFULLY COMPLETED ON-JOB TRAINING
ON

PLC & SCADA

DATED FROM

JAN 13 2020 TO JAN 18 2020

Mr. O.N. Barure
DIRECTOR

TRUSTEES
DIRECTOR (PROJECT)

Creativity through understanding fundamentals

BITC
2104



LD-Engg

Automation for life simplification

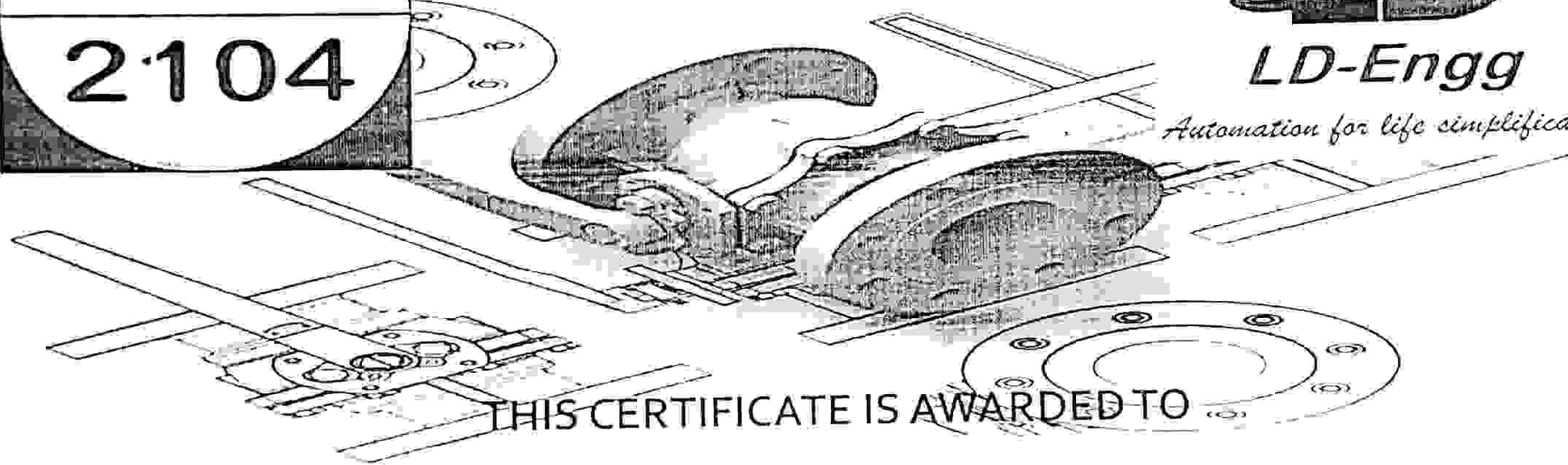

THIS CERTIFICATE IS AWARDED TO

SWAGAT VAGHARE

WHO HAS SUCCESSFULLY COMPLETED ON-JOB TRAINING
ON

PLC & SCADA

DATED FROM

JAN 13 2020 TO JAN 18 2020

TRUE COPY

[Signature]
Vishwanath (MEET)

[Signature]

Mr. O.N.Barure
DIRECTOR

Creativity through understanding fundamentals



LD-Engg

Automation for life simplification

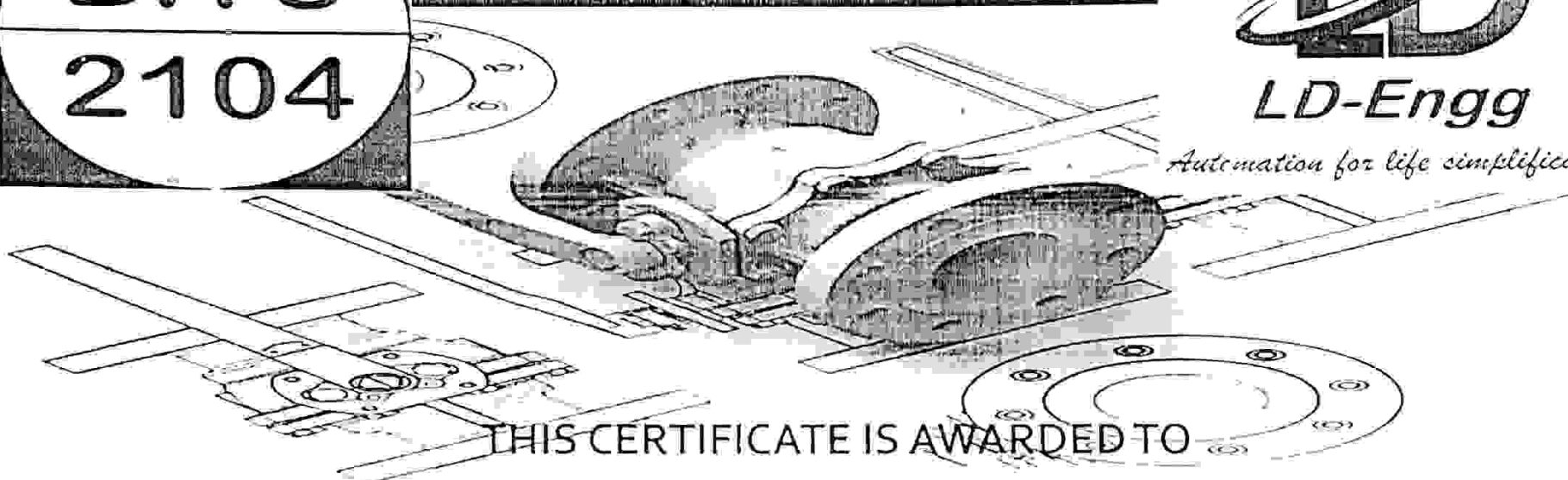

THIS CERTIFICATE IS AWARDED TO

PARAS WADAL

WHO HAS SUCCESSFULLY COMPLETED ON-JOB TRAINING
ON

PLC & SCADA

DATED FROM

JAN 13 2020 TO JAN 18 2020

Handwritten signature of Mr. O.N. Barure.

Mr. O.N. Barure
DIRECTOR

TRUE COPY

Handwritten signature of Vignesh, with the name "Vignesh" written below it.

Creativity through understanding fundamentals